

## N-channel 950 V, 0.110 $\Omega$ typ., 38 A MDmesh™ K5 Power MOSFET in a TO-247 package

Datasheet - production data

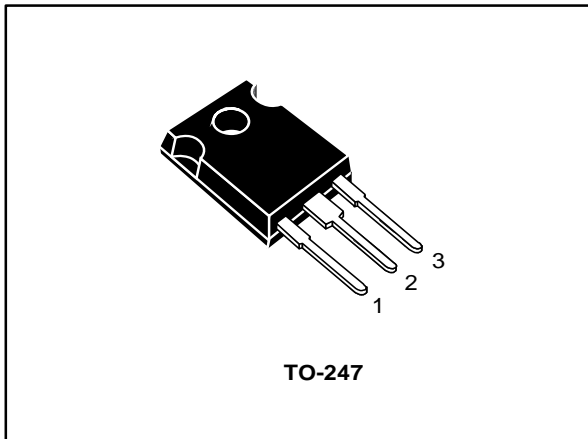
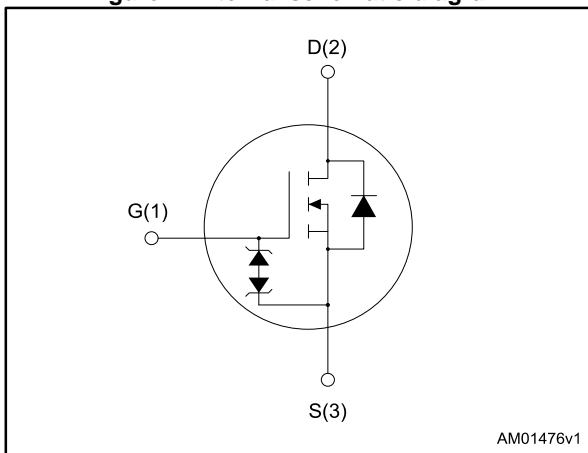

Figure 1: Internal schematic diagram



### Features

Order code	V <sub>DS</sub>	R <sub>DS(on)</sub> max	I <sub>D</sub>	P <sub>TOT</sub>
STW40N95K5	950 V	0.130 $\Omega$	38 A	450 W

- Industry's lowest R<sub>DS(on)</sub> x area
- Industry's best figure of merit (FoM)
- Ultra low gate charge
- 100% avalanche tested
- Zener-protected

### Applications

- Switching applications

### Description

This very high voltage N-channel Power MOSFET is designed using MDmesh™ K5 technology based on an innovative proprietary vertical structure. The result is a dramatic reduction in on-resistance and ultra-low gate charge for applications requiring superior power density and high efficiency.

Table 1: Device summary

Order code	Marking	Package	Packaging
STW40N95K5	40N95K5	TO-247	Tube

---

**Contents**

<b>1</b>	<b>Electrical ratings .....</b>	<b>3</b>
<b>2</b>	<b>Electrical characteristics .....</b>	<b>4</b>
	2.1 Electrical characteristics (curves) .....	6
<b>3</b>	<b>Test circuits .....</b>	<b>9</b>
<b>4</b>	<b>Package mechanical data .....</b>	<b>10</b>
	4.1 TO-247 package information .....	10
<b>5</b>	<b>Revision history .....</b>	<b>12</b>

# 1 Electrical ratings

**Table 2: Absolute maximum ratings**

Symbol	Parameter	Value	Unit
V <sub>GS</sub>	Gate- source voltage	± 30	V
I <sub>D</sub>	Drain current (continuous) at T <sub>C</sub> = 25 °C	38	A
I <sub>D</sub>	Drain current (continuous) at T <sub>C</sub> = 100 °C	24	A
I <sub>DM</sub> <sup>(1)</sup>	Drain current (pulsed)	152	A
P <sub>TOT</sub>	Total dissipation at T <sub>C</sub> = 25 °C	450	W
I <sub>AR</sub>	Max current during repetitive or single pulse avalanche	13	A
E <sub>AS</sub>	Single pulse avalanche energy (starting T <sub>J</sub> = 25 °C, I <sub>D</sub> = 13 A, V <sub>DD</sub> = 50 V)	700	mJ
dv/dt <sup>(2)</sup>	Peak diode recovery voltage slope	4.5	V/ns
dv/dt <sup>(3)</sup>	MOSFET dv/dt ruggedness	50	V/ns
T <sub>j</sub> T <sub>stg</sub>	Operating junction temperature Storage temperature	-55 to 150	°C

**Notes:**

<sup>(1)</sup>Pulse width limited by safe operating area.

<sup>(2)</sup>I<sub>SD</sub> ≤ 19 A, di/dt ≤ 100 A/μs, V<sub>DS(peak)</sub> ≤ V<sub>(BR)DSS</sub>.

<sup>(3)</sup>V<sub>DS</sub> ≤ 760 V

**Table 3: Thermal data**

Symbol	Parameter	Value	Unit
R <sub>thj-case</sub>	Thermal resistance junction-case max	0.28	°C/W
R <sub>thj-amb</sub>	Thermal resistance junction-amb max	50	°C/W

## 2 Electrical characteristics

( $T_{\text{case}} = 25\text{ °C}$  unless otherwise specified)

**Table 4: On /off states**

Symbol	Parameter	Test conditions	Min.	Typ.	Max.	Unit
$V_{(BR)DSS}$	Drain-source breakdown voltage	$V_{GS} = 0, I_D = 1\text{ mA}$	950			V
$I_{DSS}$	Zero gate voltage drain current	$V_{GS} = 0, V_{DS} = 950\text{ V}$			1	$\mu\text{A}$
		$V_{GS} = 0, V_{DS} = 950\text{ V}, T_C = 125\text{ °C}$			50	$\mu\text{A}$
$I_{GSS}$	Gate-body leakage current	$V_{DS} = 0, V_{GS} = \pm 20\text{ V}$			$\pm 10$	$\mu\text{A}$
$V_{GS(th)}$	Gate threshold voltage	$V_{DS} = V_{GS}, I_D = 100\text{ }\mu\text{A}$	3	4	5	V
$R_{DS(on)}$	Static drain-source on-resistance	$V_{GS} = 10\text{ V}, I_D = 19\text{ A}$		0.110	0.130	$\Omega$

**Table 5: Dynamic**

Symbol	Parameter	Test conditions	Min.	Typ.	Max.	Unit
$C_{iss}$	Input capacitance	$V_{GS} = 0, V_{DS} = 100\text{ V}, f = 1\text{ MHz}$	-	3300	-	pF
$C_{oss}$	Output capacitance		-	250	-	pF
$C_{riss}$	Reverse transfer capacitance		-	2	-	pF
$C_{o(tr)}^{(1)}$	Equivalent capacitance time related	$V_{GS} = 0, V_{DS} = 0\text{ to }760\text{ V}$	-	398	-	pF
$C_{o(er)}^{(2)}$	Equivalent capacitance energy related		-	142	-	pF
$R_G$	Intrinsic gate resistance	$f = 1\text{ MHz}, I_D = 0$	-	5	-	$\Omega$
$Q_g$	Total gate charge	$V_{DD} = 760\text{ V}, I_D = 38\text{ A}$	-	93	-	nC
$Q_{gs}$	Gate-source charge	$V_{GS} = 10\text{ V}$	-	18.7	-	nC
$Q_{gd}$	Gate-drain charge	(see <a href="#">Figure 16: "Gate charge test circuit"</a> )	-	63.4	-	nC

**Notes:**

(1)Time related is defined as a constant equivalent capacitance giving the same charging time as  $C_{oss}$  when  $V_{DS}$  increases from 0 to 80%  $V_{DSS}$

(2)energy related is defined as a constant equivalent capacitance giving the same stored energy as  $C_{oss}$  when  $V_{DS}$  increases from 0 to 80%  $V_{DSS}$

**Table 6: Switching times**

Symbol	Parameter	Test conditions	Min.	Typ.	Max	Unit
$t_{d(on)}$	Turn-on delay time	$V_{DD} = 475\text{ V}, I_D = 19\text{ A}, R_G = 4.7\text{ }\Omega, V_{GS} = 10\text{ V}$ (see <a href="#">Figure 15: "Switching times test circuit for resistive load"</a> )	-	33.5	-	ns
$t_r$	Rise time		-	51	-	ns
$t_{d(off)}$	Turn-off-delay time		-	91.5	-	ns
$t_f$	Fall time		-	10	-	ns

Table 7: Source drain diode

Symbol	Parameter	Test conditions	Min.	Typ.	Max	Unit
$I_{SD}$	Source-drain current		-		38	A
$I_{SDM}^{(1)}$	Source-drain current (pulsed)		-		152	A
$V_{SD}^{(2)}$	Forward on voltage	$I_{SD} = 38 \text{ A}$ , $V_{GS} = 0$	-		1.5	V
$t_{rr}$	Reverse recovery time	$I_{SD} = 38 \text{ A}$ , $di/dt = 100 \text{ A}/\mu\text{s}$ $V_{DD} = 60 \text{ V}$ (see <a href="#">Figure 18: "Unclamped inductive load test circuit"</a> )	-	706		ns
$Q_{rr}$	Reverse recovery charge		-	22		$\mu\text{C}$
$I_{RRM}$	Reverse recovery current		-	62		A
$t_{rr}$	Reverse recovery time	$I_{SD} = 38 \text{ A}$ , $di/dt = 100 \text{ A}/\mu\text{s}$ $V_{DD} = 60 \text{ V}$ , $T_J = 150 \text{ }^\circ\text{C}$ (see <a href="#">Figure 18: "Unclamped inductive load test circuit"</a> )	-	886		ns
$Q_{rr}$	Reverse recovery charge		-	28.2		$\mu\text{C}$
$I_{RRM}$	Reverse recovery current		-	64		A

**Notes:**

(1)Pulse width limited by safe operating area.

(2)Pulsed: pulse duration = 300  $\mu\text{s}$ , duty cycle 1.5%

Table 8: Gate-source Zener diode

Symbol	Parameter	Test conditions	Min	Typ.	Max.	Unit
$V_{(BR)GSO}$	Gate-source breakdown voltage	$I_{GS} = \pm 1 \text{ mA}$ , $I_D = 0$	30	-	-	V

The built-in back-to-back Zener diodes have specifically been designed to enhance the device's ESD capability. In this respect the Zener voltage is appropriate to achieve an efficient and cost-effective intervention to protect the device's integrity. These integrated Zener diodes thus avoid the usage of external components.

## 2.1 Electrical characteristics (curves)

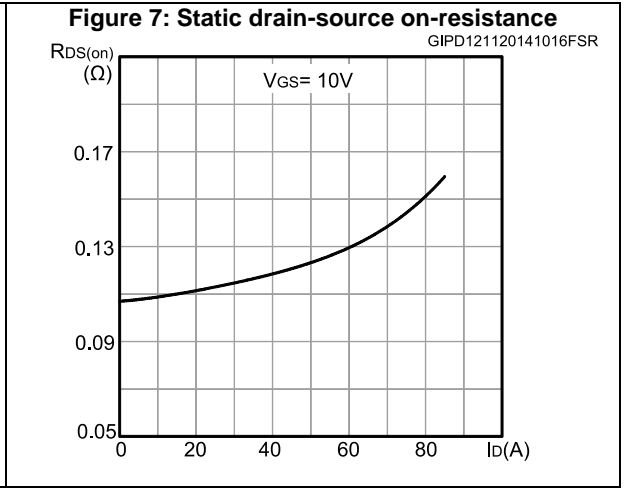
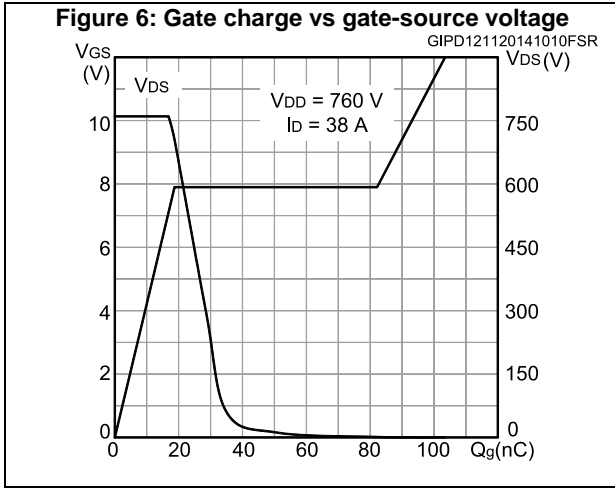
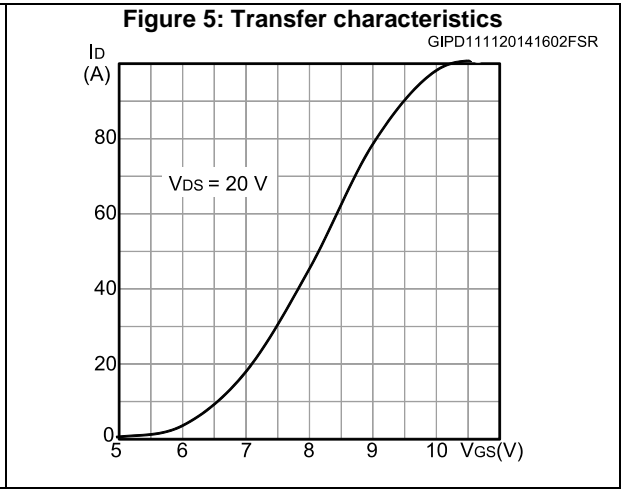
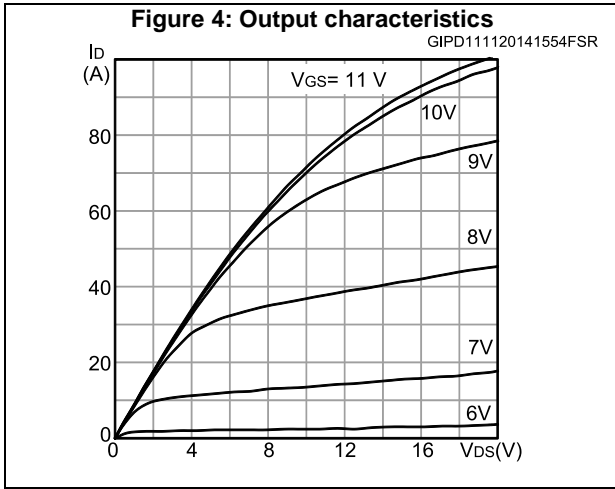
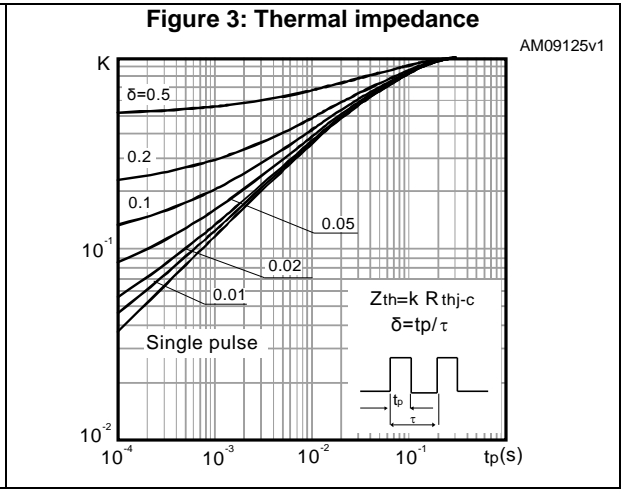
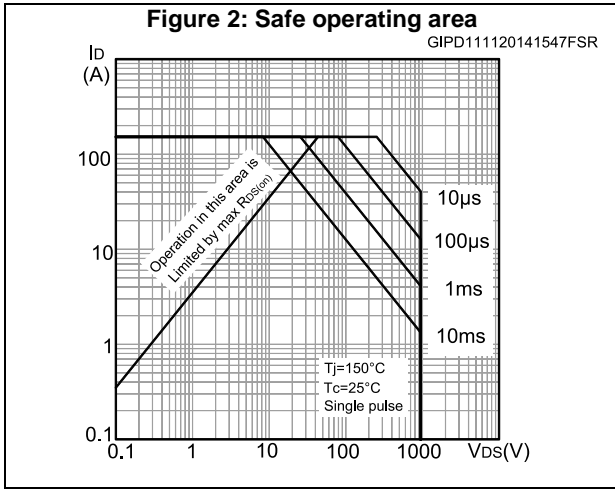

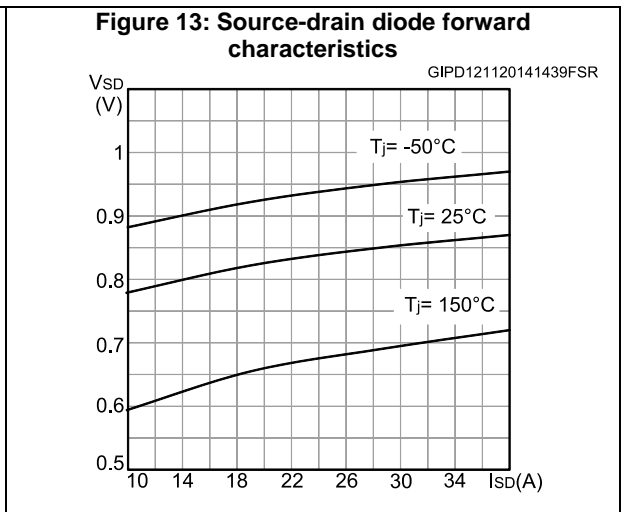
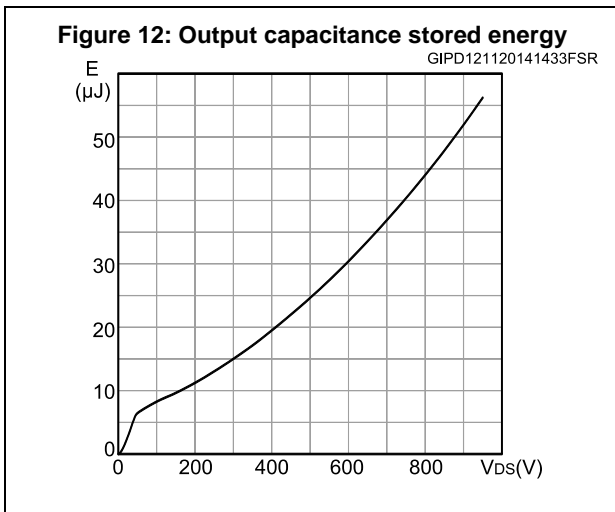
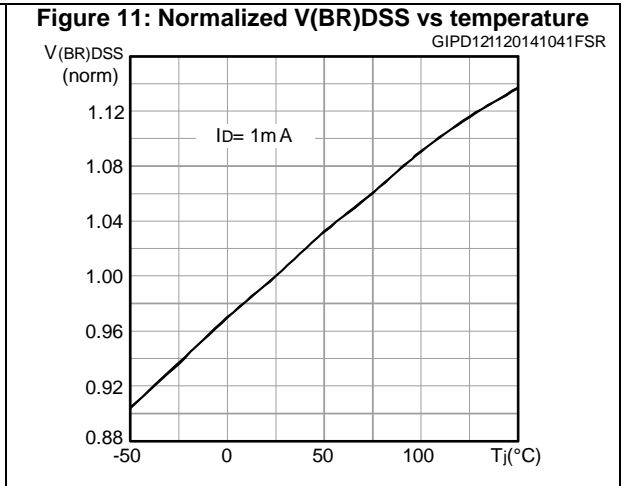
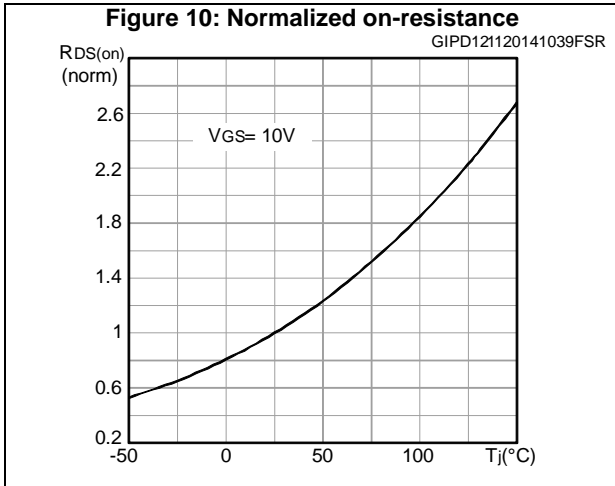
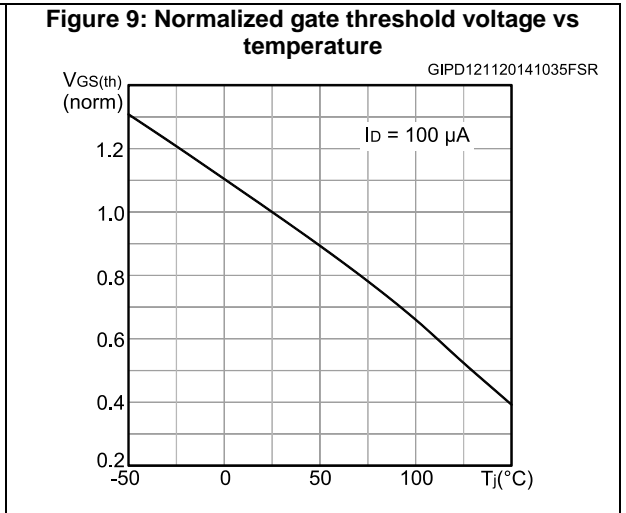
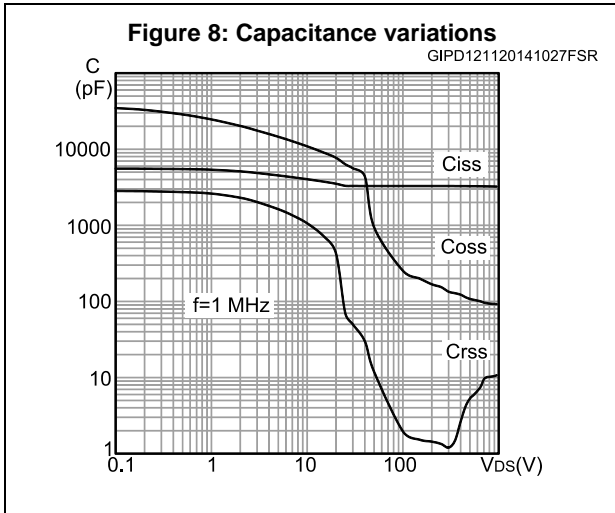
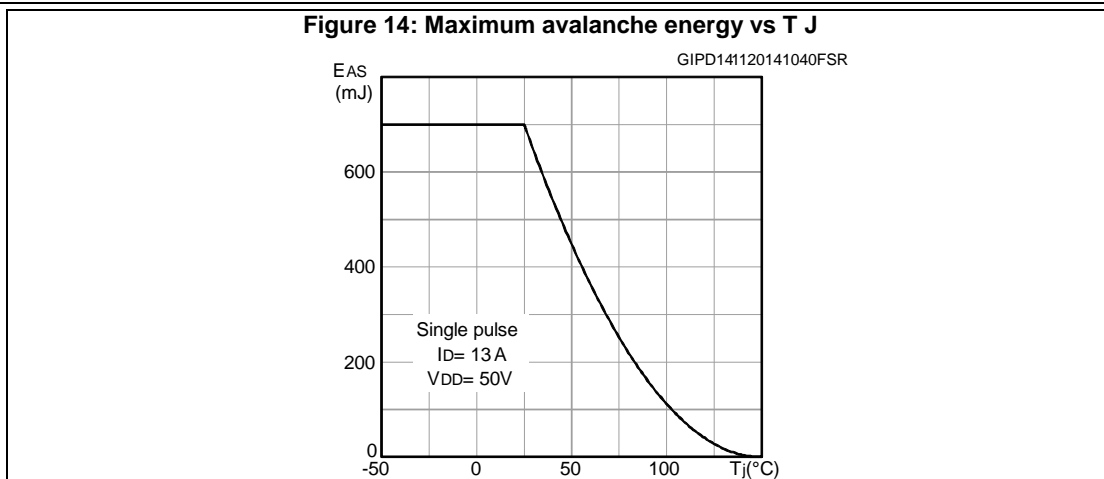
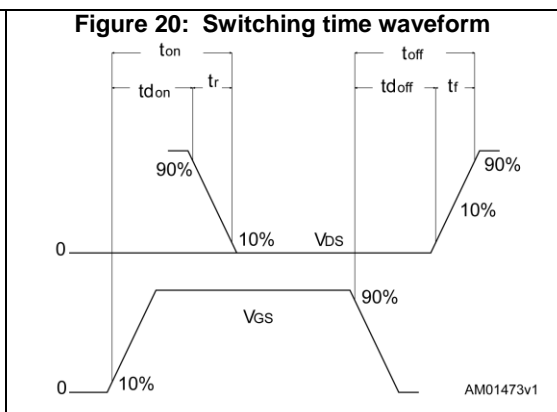
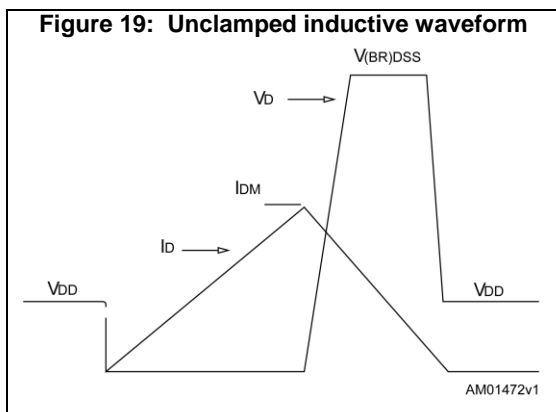
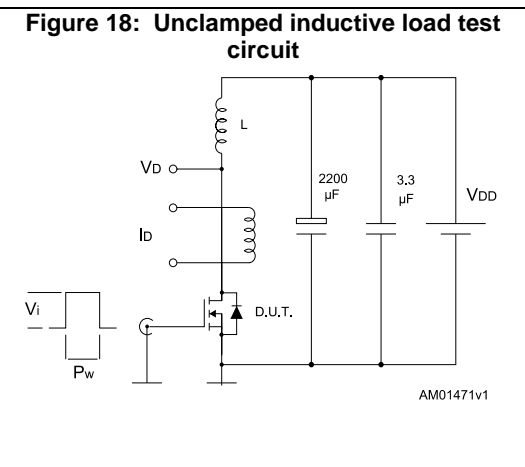
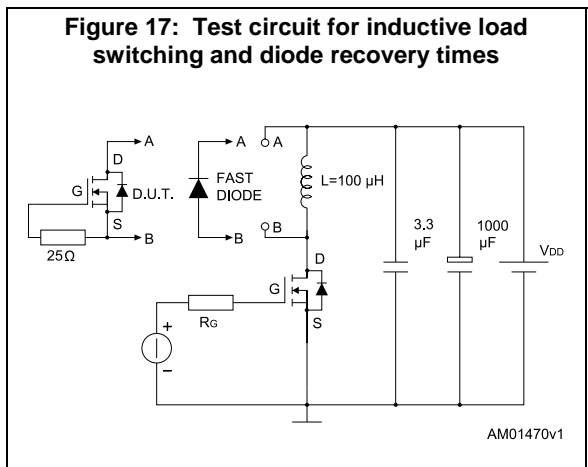
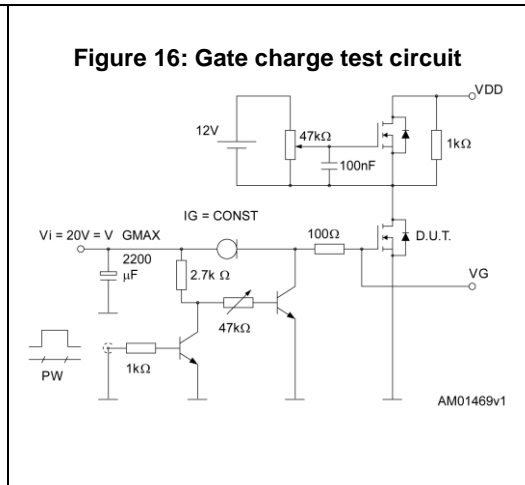
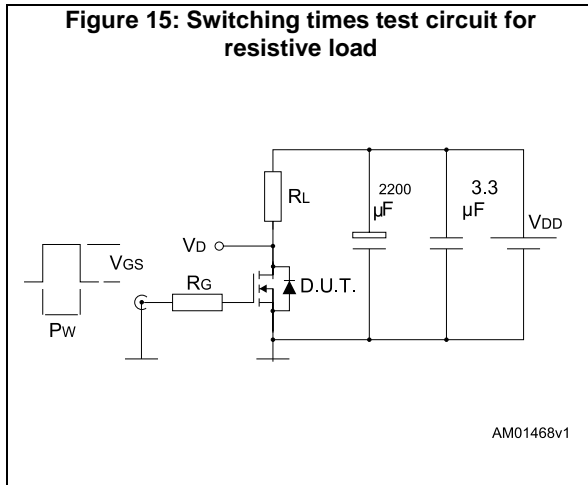

Figure 14: Maximum avalanche energy vs T J





### 3 Test circuits



## 4 Package mechanical data

In order to meet environmental requirements, ST offers these devices in different grades of ECOPACK® packages, depending on their level of environmental compliance. ECOPACK® specifications, grade definitions and product status are available at: [www.st.com](http://www.st.com). ECOPACK® is an ST trademark.

### 4.1 TO-247 package information

Figure 21: TO-247 drawing

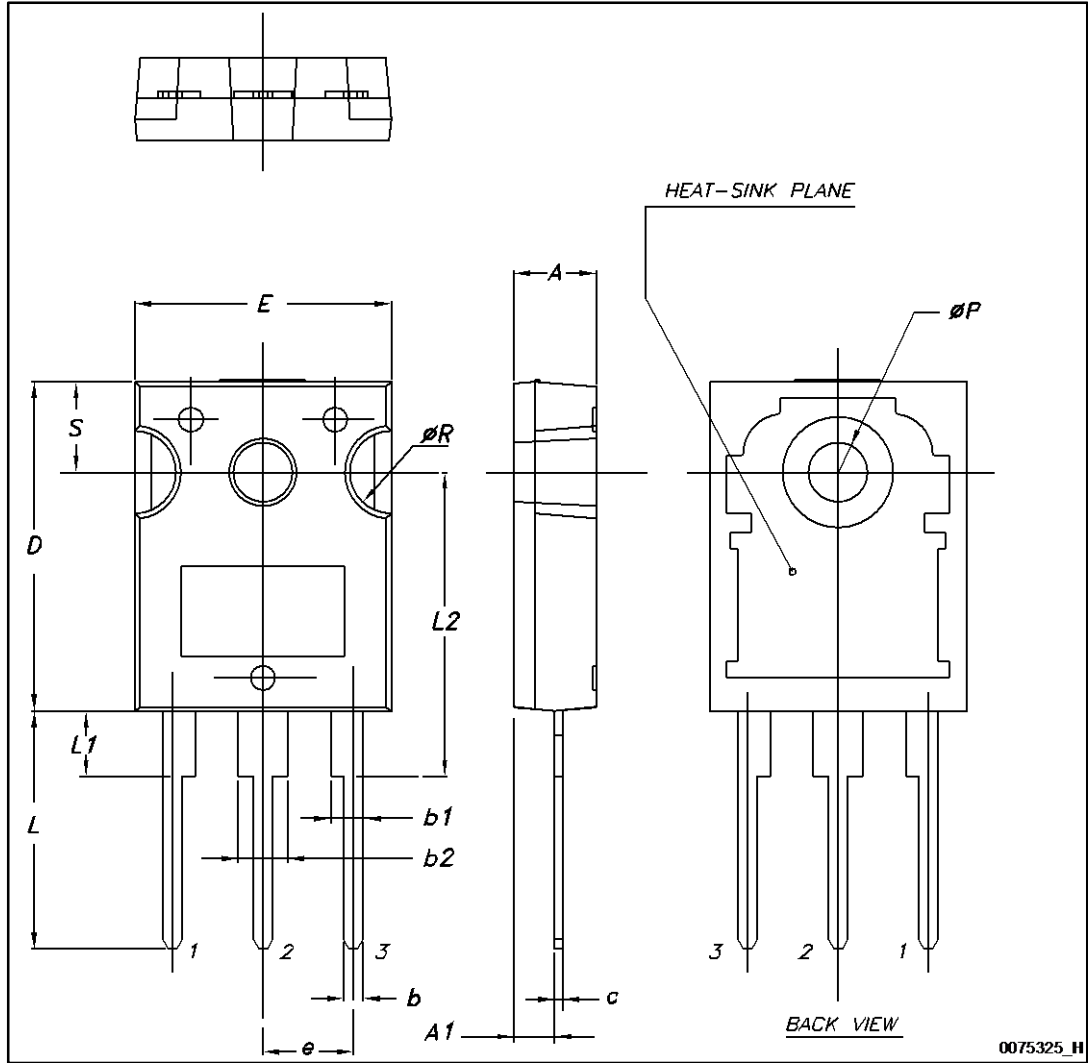

Table 9: TO-247 mechanical data

Dim.	mm.		
	Min.	Typ.	Max.
A	4.85		5.15
A1	2.20		2.60
b	1.0		1.40
b1	2.0		2.40
b2	3.0		3.40
c	0.40		0.80
D	19.85		20.15
E	15.45		15.75
e	5.30	5.45	5.60
L	14.20		14.80
L1	3.70		4.30
L2		18.50	
ØP	3.55		3.65
ØR	4.50		5.50
S	5.30	5.50	5.70

## 5 Revision history

Table 10: Document revision history

Date	Revision	Changes
03-Jun-2014	1	First release.
14-Nov-2014	2	Document status promoted from preliminary to production data. Added <a href="#">Section 2.1: "Electrical characteristics (curves)"</a> .

**IMPORTANT NOTICE – PLEASE READ CAREFULLY**

STMicroelectronics NV and its subsidiaries ("ST") reserve the right to make changes, corrections, enhancements, modifications, and improvements to ST products and/or to this document at any time without notice. Purchasers should obtain the latest relevant information on ST products before placing orders. ST products are sold pursuant to ST's terms and conditions of sale in place at the time of order acknowledgement.

Purchasers are solely responsible for the choice, selection, and use of ST products and ST assumes no liability for application assistance or the design of Purchasers' products.

No license, express or implied, to any intellectual property right is granted by ST herein.

Resale of ST products with provisions different from the information set forth herein shall void any warranty granted by ST for such product.

ST and the ST logo are trademarks of ST. All other product or service names are the property of their respective owners.

Information in this document supersedes and replaces information previously supplied in any prior versions of this document.

© 2014 STMicroelectronics – All rights reserved

单击下面可查看定价，库存，交付和生命周期等信息

[>>STMicro\(意法半导体\)](#)