



**L4964**

## HIGH CURRENT SWITCHING REGULATOR

- 4 A OUTPUT CURRENT
- 5.1 V TO 28 V OUTPUT VOLTAGE RANGE
- 0 TO 100 % DUTY CYCLE RANGE
- PRECISE ( $\pm 3\%$ ) ON-CHIP REFERENCE
- SWITCHING FREQUENCY UP TO 120 KHz
- VERY HIGH EFFICIENCY (UP TO 90 %)
- VERY FEW EXTERNAL COMPONENTS
- SOFT START
- RESET OUTPUT
- CURRENT LIMITING
- INPUT FOR REMOTE INHIBIT AND SYNCHRONOUS PWM
- THERMAL SHUTDOWN

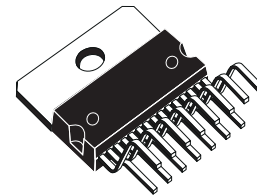
### DESCRIPTION

The L4964 is a stepdown power switching regulator delivering 4A at a voltage variable from 5.1V to 28V.

Features of the device include overload protection, soft start, remote inhibit, thermal protection, a reset output for microprocessors and a PWM comparator input for synchronization in multichip configurations.

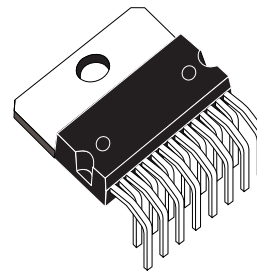
The L4964 is mounted in a 15-lead Multiwatt® plastic power package and requires very few external components.

Efficient operation at switching frequencies up to 120kHz allows a reduction in the size and cost of external filter components.



**MULTIWATT15 Vertical**  
(Plastic Package)

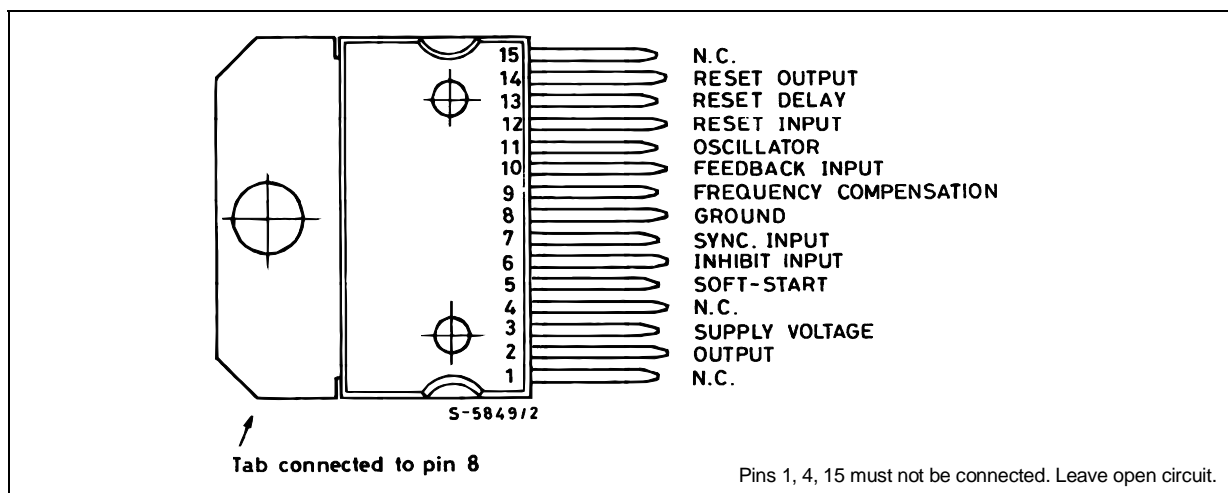
ORDERING NUMBER : L4964



**MULTIWATT15 Horizontal**  
(Plastic Package)

ORDERING NUMBER : L4964HT

### PIN CONNECTION (top view)

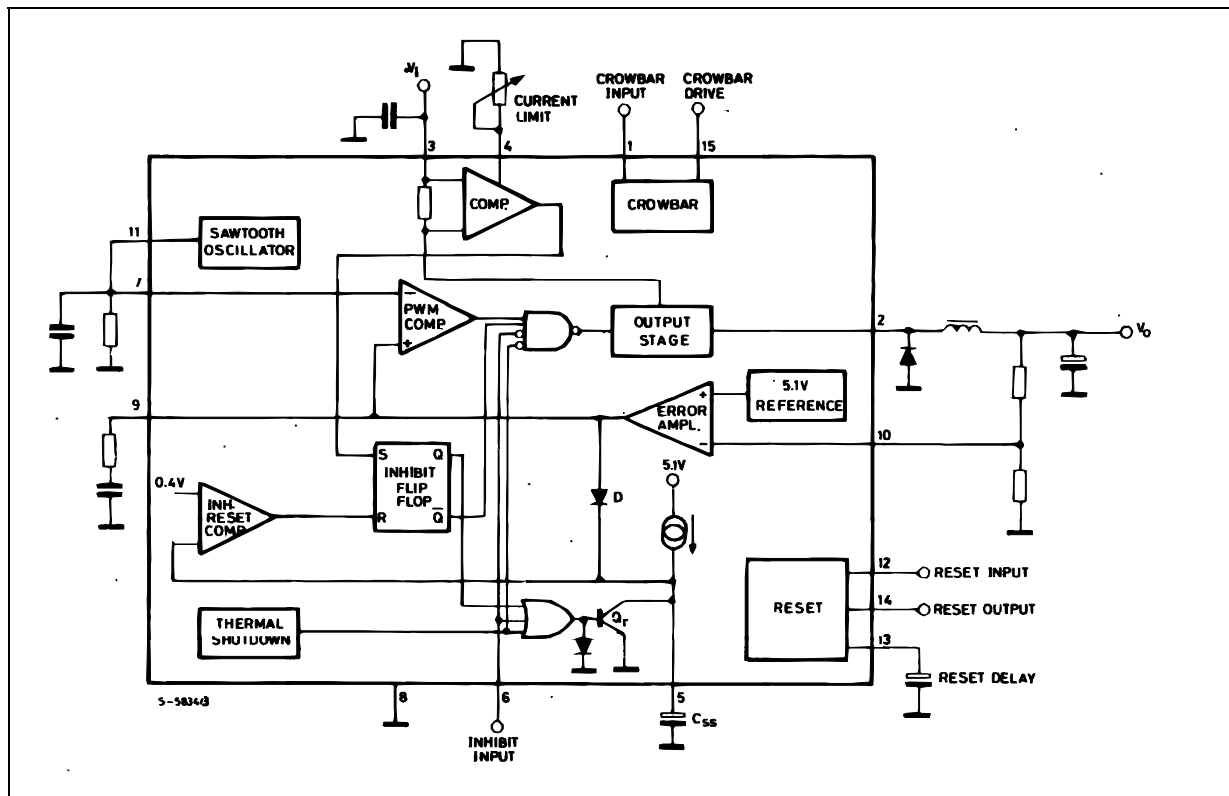


# L4964

## PIN FUNCTIONS

N°	Name	Function
1	N.C.	Must not be connected. Leave open circuit.
2	Output	Regulator Output.
3	Supply Voltage	Unregulated Voltage Input. An internal regulator powers the L4964's internal logic.
4	N.C.	Must not be connected. Leave open circuit.
5	Soft Start	Soft Start Time Constant. A capacitor is connected between this terminal and ground to define the soft start time constant. This capacitor also determines the average short circuit output current.
6	Inhibit Input	TTL - Level Remote Inhibit. A logic high level on this input disables the L4964.
7	Sync Input	Multiple L4964's are synchronized by connecting the pin 7 inputs together and omitting the oscillator RC network on all but one device.
8	Ground	Common Ground Terminal.
9	Frequency Compensation	A series RC network connected between this terminal and ground determines the regulation loop gain characteristics.
10	Feedback Input	The Feedback Terminal of the Regulation Loop. The output is connected directly to this terminal for 5.1 V operation ; it is connected via a divider for higher voltages.
11	Oscillator	A parallel RC network connected to this terminal determines the switching frequency. The pin must be connected to pin 7 input when the internal oscillator is used.
12	Reset Input	Input of the Reset Circuit. The threshold is roughly 5 V. It may be connected to the beedback point or via a divider to the input.
13	Reset Delay	A capacitor connected between this terminal and ground determines the reset signal delay time.
14	Reset Output	Open Collector Reset Signal Output. This output is high when the supply is safe.
15	N.C.	Must not be connected. Leave open circuit.

## BLOCK DIAGRAM



### CIRCUIT OPERATION (refer to the block diagram)

The L4964 is a monolithic stepdown switching regulator providing output voltages from 5.1 V to 28 V and delivering 4A.

The regulation loop consists of a sawtooth oscillator, error amplifier, comparator and the output stage. An error signal is produced by comparing the output voltage with a precise 5.1 V on-chip reference (zener zap trimmed to  $\pm 3\%$ ). This error signal is then compared with the sawtooth signal to generate the fixed frequency pulse width modulated pulses which drive the output stage. The gain and frequency stability of the loop can be adjusted by an external RC network connected to pin 9. Closing the loop directly gives an output voltage of 5.1 V. Higher voltages are obtained by inserting a voltage divider.

Output overcurrents at switch on are prevented by the soft start function. The error amplifier output is initially clamped by the external capacitor  $C_{SS}$  and allowed to rise, linearly, as this capacitor is charged by a constant current source.

Output overload protection is provided in the form of a current limiter. The load current is sensed by an internal metal resistor connected to a comparator. When the load current exceeds a preset threshold this comparator sets a flip flop which disables the output stage and discharges the soft start capacitor.

A second comparator resets the flip flop when the voltage across the soft start capacitor has fallen to 0.4 V. The output stage is thus re-enabled and the output voltage rises under control of the soft start network. If the overload condition is still present the limiter will trigger again when the threshold current is reached. The average short circuit current is limited to a safe value by the dead time introduced by the soft start network.

The reset circuit generates an output signal when the supply voltage exceeds a threshold programmed by an external divider. The reset signal is generated with a delay time programmed by an external capacitor. When the supply falls below the threshold the reset output goes low immediately. The reset output is an open collector.

A TTL - level input is provided for applications such as remote on/off control. This input is activated by high level and disables circuit operation. After an inhibit the L4964 restarts under control of the soft start network.

The thermal overload circuit disables circuit operation when the junction temperature reaches about 150 and has hysteresis to prevent unstable conditions.

Figure 1 : Reset Output Waveforms

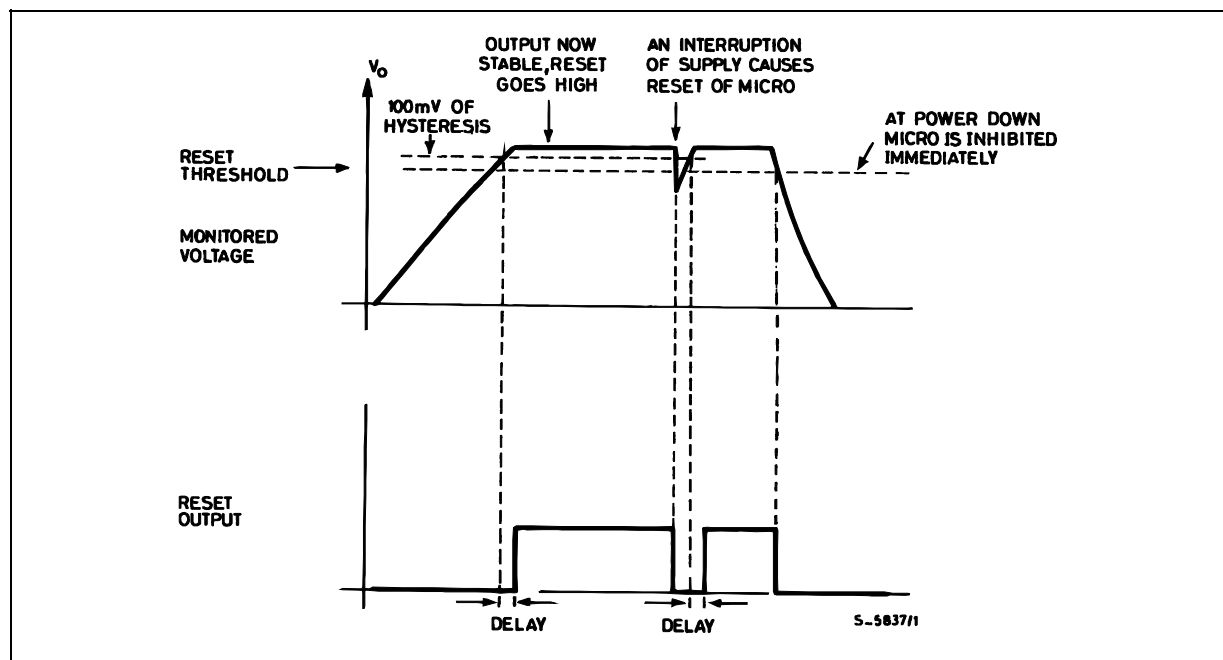


Figure 2 : Soft Start Waveforms

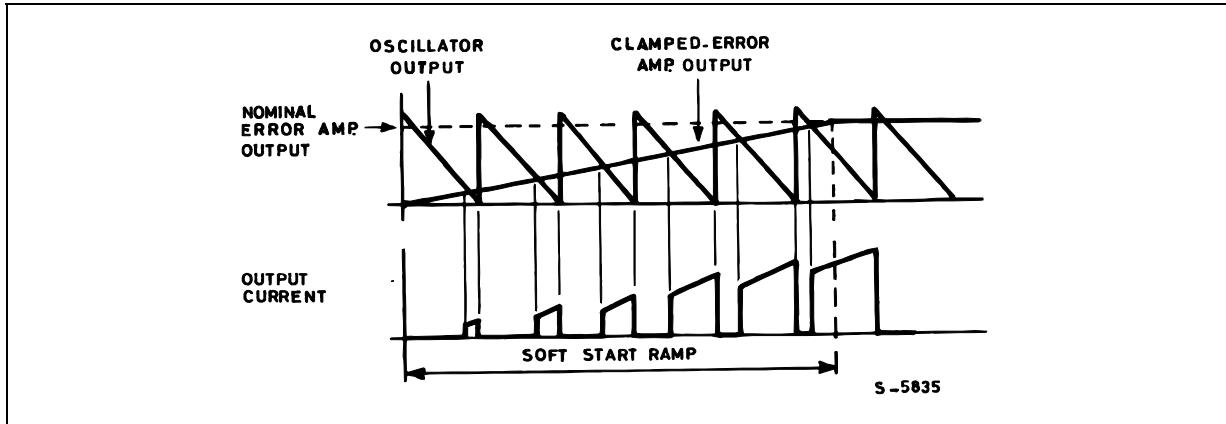
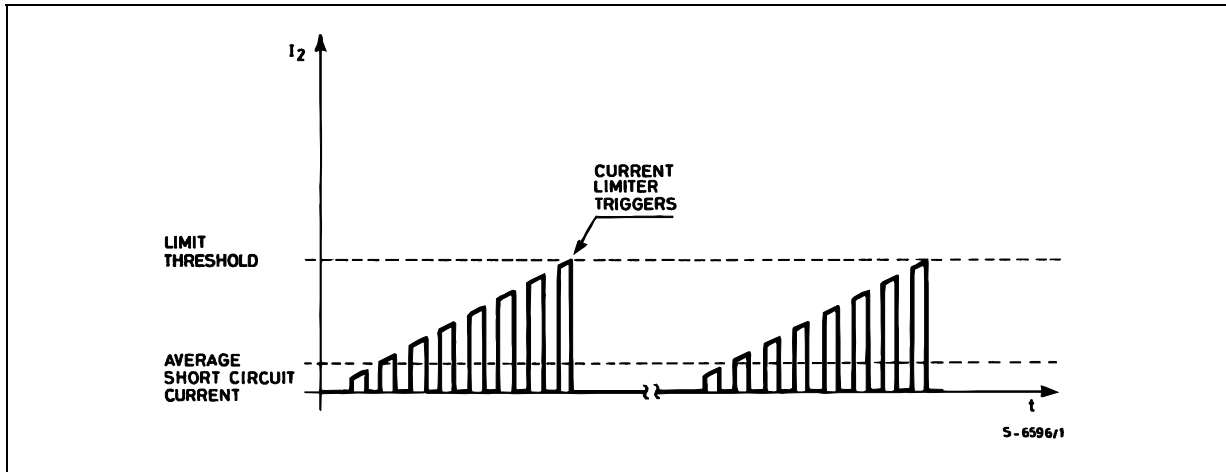


Figure 3 : Current Limiter Waveforms



**ABSOLUTE MAXIMUM RATINGS**

Symbol	Parameter	Value	Unit
$V_i$	Input Voltage (pin 3)	36	V
$V_i - V_2$	Input to Output Voltage Difference	38	V
$V_2$	Output DC Voltage	-1	V
	Output Peak Voltage at $t = 0.1 \mu\text{sec}$ $f = 100 \text{ kHz}$	-7	V
$V_{12}$	Voltage at Pin 12	10	V
$V_5, V_7, V_9$	Voltage at Pins 5, 7 and 9	5.5	V
$V_{10}, V_6, V_{13}$	Voltage at Pins 10, 6 and 13	7	V
$V_{14}$	Voltage at Pin 14 ( $I_{14} \leq 1 \text{ mA}$ )	$V_i$	
$I_9$	Pin 9 Sink Current	1	mA
$I_{11}$	Pin 11 Source Current	20	mA
$I_{14}$	Pin 14 Sink Current ( $V_{14} < 5 \text{ V}$ )	50	mA
$P_{\text{tot}}$	Power Dissipation at $T_{\text{case}} \leq 90 \text{ }^\circ\text{C}$	20	W
$T_j, T_{\text{stg}}$	Junction and Storage Temperature	- 40 to 150	$^\circ\text{C}$

**THERMAL DATA**

Symbol	Parameter	Value	Unit
$R_{\text{th } j\text{-case}}$	Thermal Resistance Junction-case	Max. 3	$^\circ\text{C/W}$
$R_{\text{th } j\text{-amb}}$	Thermal Resistance Junction-ambient	Max. 35	$^\circ\text{C/W}$



**ELECTRICAL CHARACTERISTICS**(refer to the test circuits  $T_j = 25^\circ\text{C}$ ,  $V_i = 25\text{V}$ , unless otherwise specified)

Symbol	Parameter	Test Conditions	Min.	Typ.	Max.	Unit	Fig.
DYNAMIC CHARACTERISTICS (pin 6 to GND unless otherwise specified)							
$V_o$	Output Voltage Range	$V_i = 36\text{V}$ , $I_o = 1\text{A}$	$V_{ref}$		28	V	4
$V_i$	Input Voltage Range	$V_o = V_{ref}$ to $28\text{V}$ , $I_o = 3\text{A}$	9		36	V	4
$\Delta V_o$	Line Regulation	$V_i = 10\text{V}$ to $30\text{V}$ , $V_o = V_{ref}$ , $I_o = 2\text{A}$		15	70	mV	4
$\Delta V_o$	Load Regulation	$I_o = 1\text{A}$ to $2\text{A}$ $I_o = 0.5\text{A}$ to $3\text{A}$ , $V_o = V_{ref}$		10 15	30 50	mV	4 4
$V_{ref}$	Internal Reference Voltage (Pin 10)	$V_i = 9\text{V}$ to $36\text{V}$ , $I_o = 2\text{A}$	4.95	5.1	5.25	V	4
$\frac{\Delta V_{ref}}{\Delta T}$	Average Temperature Coefficient of Reference Voltage	$T_j = 0^\circ\text{C}$ to $125^\circ\text{C}$ , $I_o = 2\text{A}$		0.4		mV/°C	
$V_d$	Dropout Voltage between Pin 2 and Pin 3	$I_o = 3\text{A}$ $I_o = 2\text{A}$		2 1.5	3.2 2.4	V V	4 4
$I_{om}$	Maximum Operating Load Current	$V_i = 9\text{V}$ to $36\text{V}$ , $V_o = V_{ref}$ to $28\text{V}$	4			A	4
$I_{2L}$	Current Limiting Threshold (Pin 2)	$V_i = 9\text{V}$ to $36\text{V}$ , $V_o = V_{ref}$ to $28\text{V}$	4.5		8	A	4
$I_{SH}$	Input Average Current	$V_i = 36\text{V}$ , Output Short-circuited		80	140	mA	4
$\eta$	Efficiency	$I_o = 3\text{A}$ $V_o = V_{ref}$ $V_o = 12\text{V}$		75 85		% %	4 4
SVR	Supply Voltage Ripple Rejection	$\Delta V_i = 2V_{rms}$ , $f_{ripple} = 100\text{Hz}$ $V_o = V_{ref}$ , $I_o = 2\text{A}$	46	56	–	dB	4
f	Switching Frequency		40	50	60	kHz	4
$\frac{\Delta f}{\Delta V_i}$	Voltage Stability of Switching Frequency	$V_i = 9\text{V}$ to $36\text{V}$		0.5		%	4
$\frac{\Delta f}{\Delta T_j}$	Temperature Stability of Switching Frequency	$T_j = 0^\circ\text{C}$ to $125^\circ\text{C}$		1		%	4
$f_{max}$	Maximum Operating Switching Frequency	$V_o = V_{ref}$ , $I_o = 1\text{A}$	120			kHz	–
$T_{sd}$	Thermal Shutdown Junction Temperature		135	145		°C	–

**DC CHARACTERISTICS**

$I_{3Q}$	Quiescent Drain Current	$V_i = 36\text{V}$ , $V_7 = 0\text{V}$ , $S1 : B$ , $S2 : B$ $V_6 = 0\text{V}$ $V_6 = 3\text{V}$		66 30	100 50	mA	6a
$-I_{2L}$	Output Leakage Current	$V_i = 36\text{V}$ , $V_6 = 3\text{V}$ , $V_7 = 0\text{V}$ $S1 : B$ , $S2 : A$			2	mA	6a

**SOFT START**

$I_{5so}$	Source Current	$V_6 = 0\text{V}$ , $V_5 = 3\text{V}$	80	130	180	$\mu\text{A}$	6b
$I_{5si}$	Sink Current	$V_6 = 3\text{V}$ , $V_5 = 3\text{V}$	40	70	140	$\mu\text{A}$	6b

**INHIBIT**

$V_{6L}$	Low Input Voltage	$V_i = 9\text{V}$ to $36\text{V}$ , $V_7 = 0\text{V}$ $S1 : B$ , $S2 : B$	- 0.3		0.8	V	6a
$V_{6H}$	High Input Voltage		2		5.5	V	6a
	Input Current with Input Voltage	$V_i = 9\text{V}$ to $36\text{V}$ , $V_7 = 0\text{V}$ $S1 : B$ , $S2 : B$				$\mu\text{A}$	6a
$-I_{6L}$	Low Level	$V_6 = 0.8\text{V}$			20		
$-I_{6H}$	High Level	$V_6 = 2\text{V}$			10		

**ERROR AMPLIFIER**

$V_{9H}$	High Level Output Voltage	$V_{10} = 4.7\text{V}$ , $I_9 = 100\mu\text{A}$ , $S1 : A$ , $S2 : A$	3.4			V	6c
$V_{9L}$	Low Level Output Voltage	$V_{10} = 5.3\text{V}$ , $I_9 = 100\mu\text{A}$ , $S1 : A$ , $S2 : E$			0.6	V	6c
$I_{9si}$	Sink Output Current	$V_{10} = 5.3\text{V}$ , $S1 : A$ , $S2 : B$	100	150		$\mu\text{A}$	6c
$-I_{9so}$	Source Output Current	$V_{10} = 4.7\text{V}$ , $S1 : A$ , $S2 : D$	100	150		$\mu\text{A}$	6c



# L4964

## ELECTRICAL CHARACTERISTICS (continued)

(refer to the test circuits  $T_j = 25^\circ\text{C}$ ,  $V_i = 25\text{V}$ , unless otherwise specified)

Symbol	Parameter	Test Conditions	Min.	Typ.	Max.	Unit	Fig.
--------	-----------	-----------------	------	------	------	------	------

### ERROR AMPLIFIER (continued)

$I_{10}$	Input Bias Current	$V_{10} = 5.2\text{V}$ , S1 : B		2	20	$\mu\text{A}$	6c
$G_v$	DC Open Loop Gain	$V_9 = 1\text{V}$ to $3\text{V}$ , S1 : A, S2 : C	40	55		dB	6c

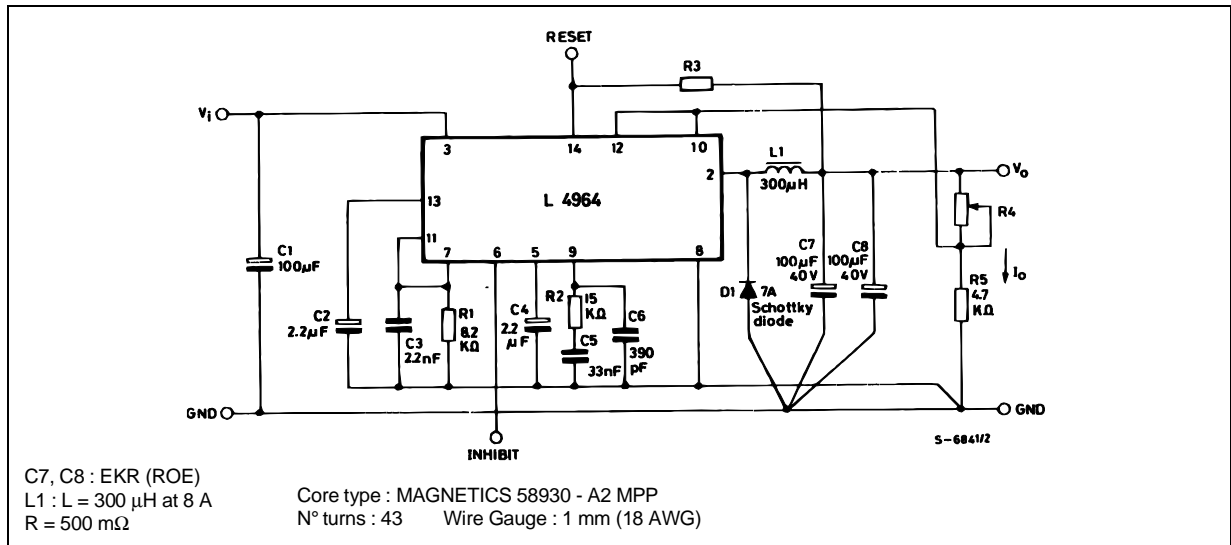
### OSCILLATOR AND PWM COMPARATOR

-I <sub>7</sub>	Input Bias Current of PWM Comparator	$V_7 = 0.5\text{V}$ to $3.5\text{V}$			10	$\mu\text{A}$	6a
-I <sub>11</sub>	Oscillator Source Current	$V_{11} = 2\text{V}$ , S1 : A, S2 : B	4		-	mA	6a

### RESET

$V_{12R}$	Rising Threshold Voltage	$V_i = 9\text{V}$ to $36\text{V}$ , S1 : B, S2 : B	$V_{\text{ref}} - 150\text{mV}$	$V_{\text{ref}} - 100\text{mV}$	$V_{\text{ref}} - 50\text{mV}$	V	6d
$V_{12F}$	Falling Threshold Voltage		4.75	$V_{\text{ref}} - 150\text{mV}$	$V_{\text{ref}} - 100\text{mV}$	V	6d
$V_{13D}$	Delay Threshold Voltage	$V_{12} = 5.3\text{V}$ , S1 : A, S2 : B	4.3	4.5	4.7	V	6d
$V_{13H}$	Delay Threshold Voltage Hysteresis			100		mV	6d
$V_{14S}$	Output Saturation Volt.	$I_{14} = 5\text{mA}$ , $V_{12} = 4.7\text{V}$ - S1, S2 : B			0.4	V	6d
$I_{12}$	Input Bias Current	$V_{12} = 0\text{V}$ to $V_{\text{ref}}$ , S1 : B, S2 : B		1	10	$\mu\text{A}$	6d
-I <sub>13 so</sub> I <sub>13 si</sub>	Delay Source Current Delay Sink Current	$V_{13} = 3\text{V}$ , S1 : A, S2 : B $V_{12} = 5.3\text{V}$ $V_{12} = 4.7\text{V}$	60 8	110	150	$\mu\text{A}$ mA	6d
$I_{14}$	Output Leakage Current	$V_i = 36\text{V}$ , $V_{12} = 5.3\text{V}$ , S1 : B, S2 : A		100		$\mu\text{A}$	6d

Figure 4 : Dynamic Test Circuit



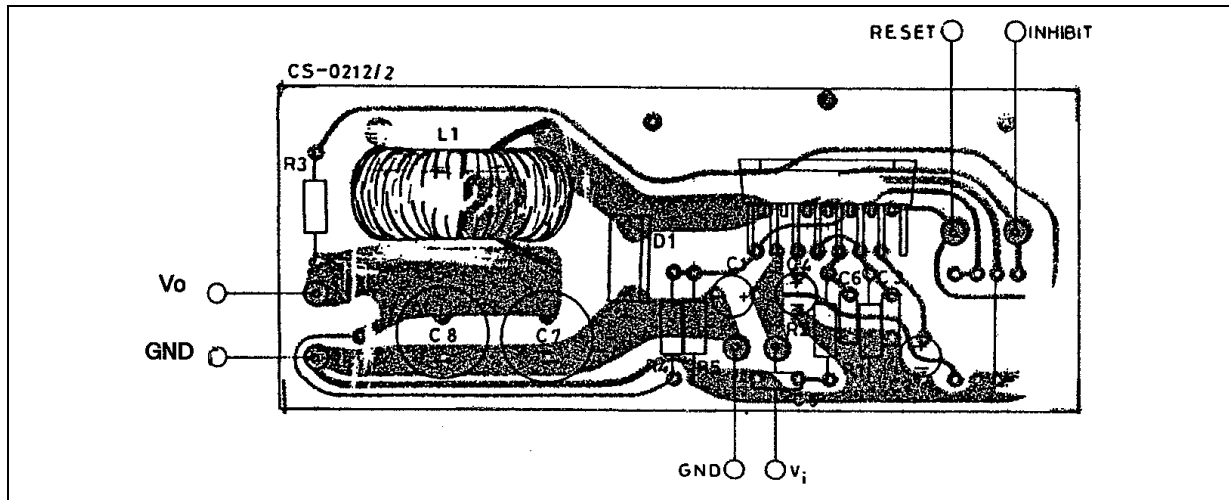
**Figure 5** : PC. Board and Component Layout of the Circuit of Fig. 4 (1:1 scale)

Figure 6 : DC Test Circuits.

Figure 6a.

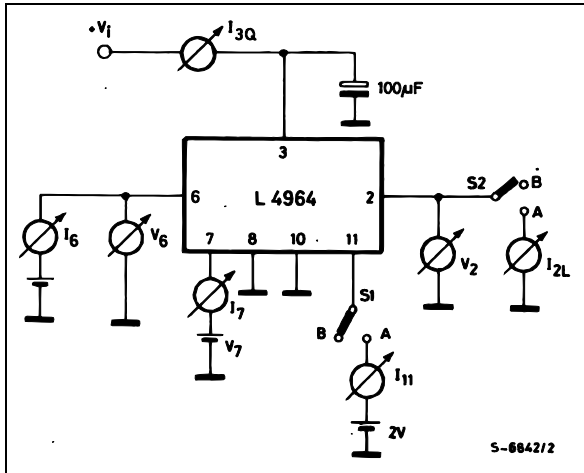


Figure 6b.

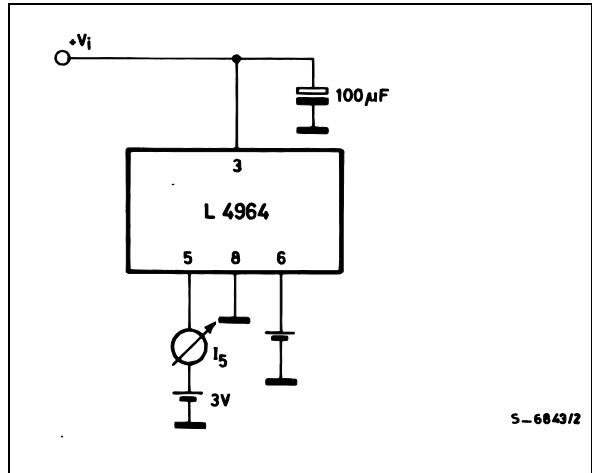


Figure 6c.

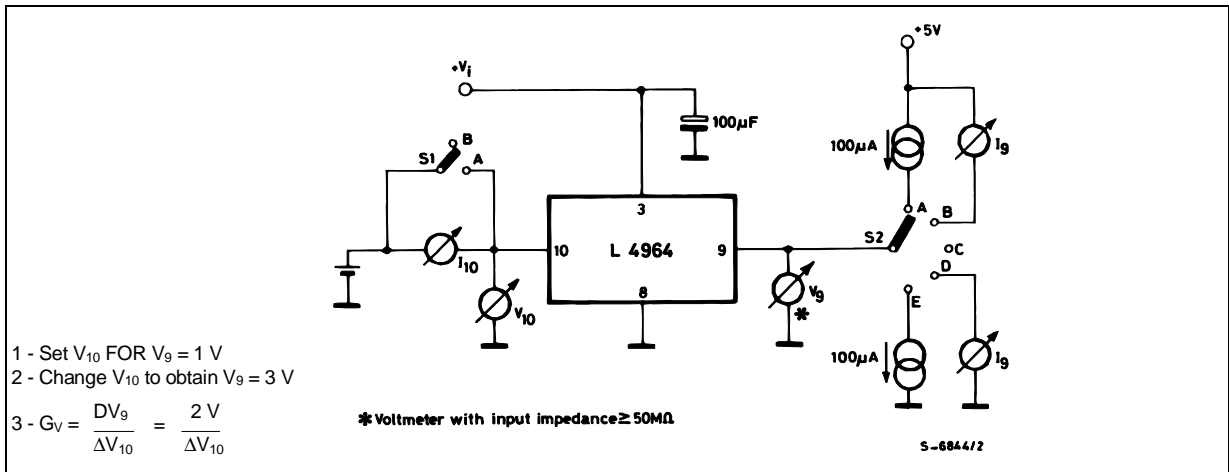


Figure 6d.

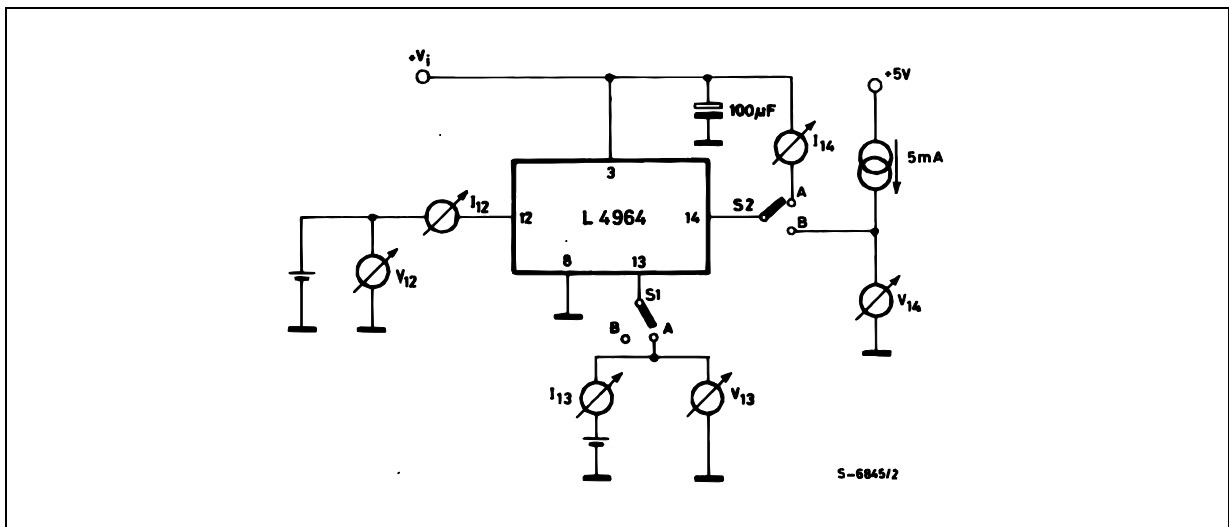




Figure 7 : Switching Frequency vs. R1 (see fig. 4).

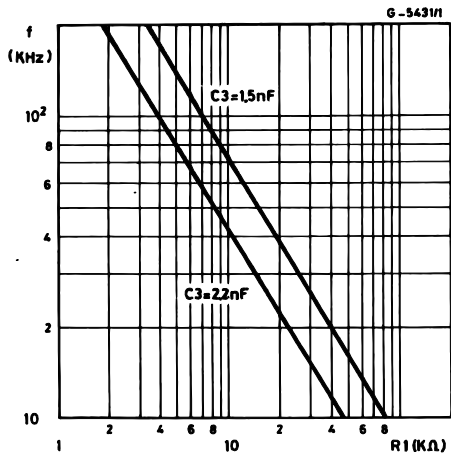


Figure 8 : Open Loop Frequency and Phase Response of Error Amplifier (see fig. 6c).

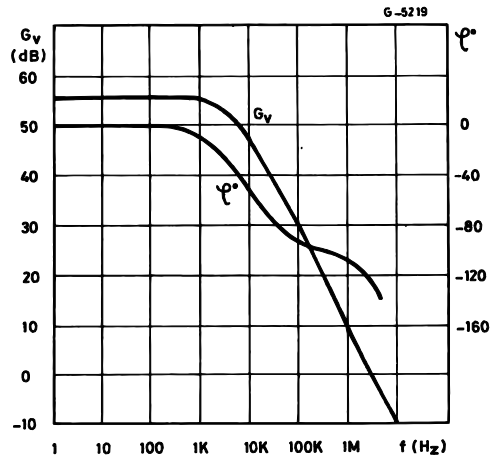


Figure 9 : Reference Voltage (pin 10) vs. Junction Temperature (see fig. 4).

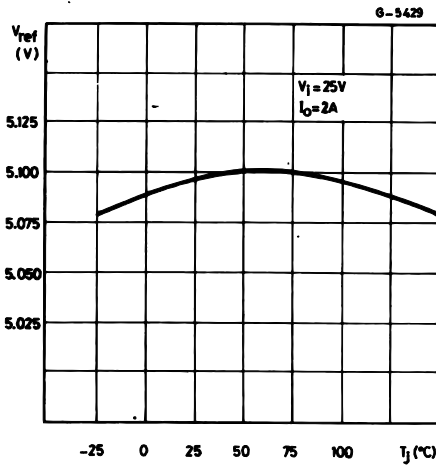


Figure 10 : Power Dissipation (L4964 only) vs. Input Voltage.

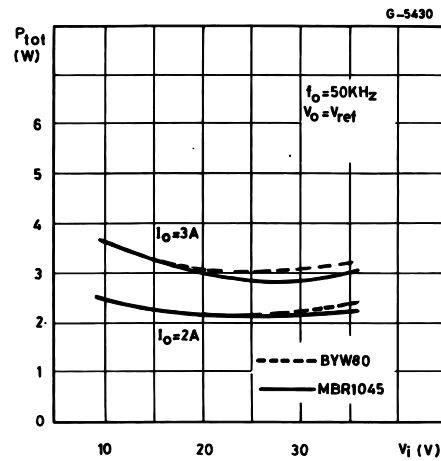


Figure 11 : Efficiency vs. Output Voltage.

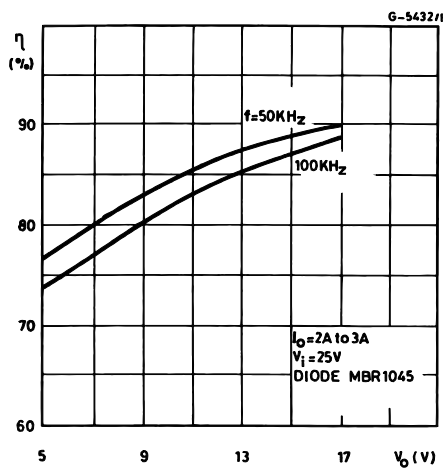
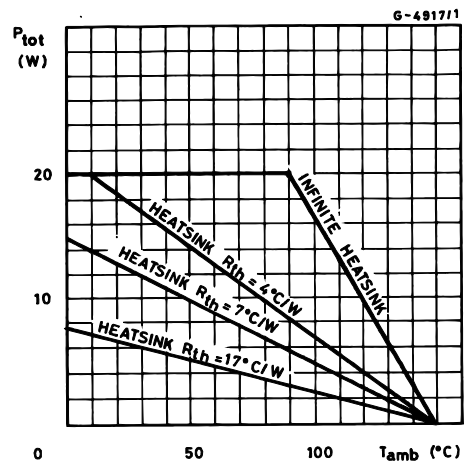


Figure 12 : Power Dissipation Derrating Curve.



**APPLICATION INFORMATION**

**CHOOSING THE INDUCTOR AND CAPACITOR**  
 The input and output capacitors of the L4964 must have a low ESR and low inductance at high current ripple.

Preferably, the inductor should be a toroidal type or wound on a Moly-Permalloy nucleus. Saturation must not occur at current levels below 1.5 times the

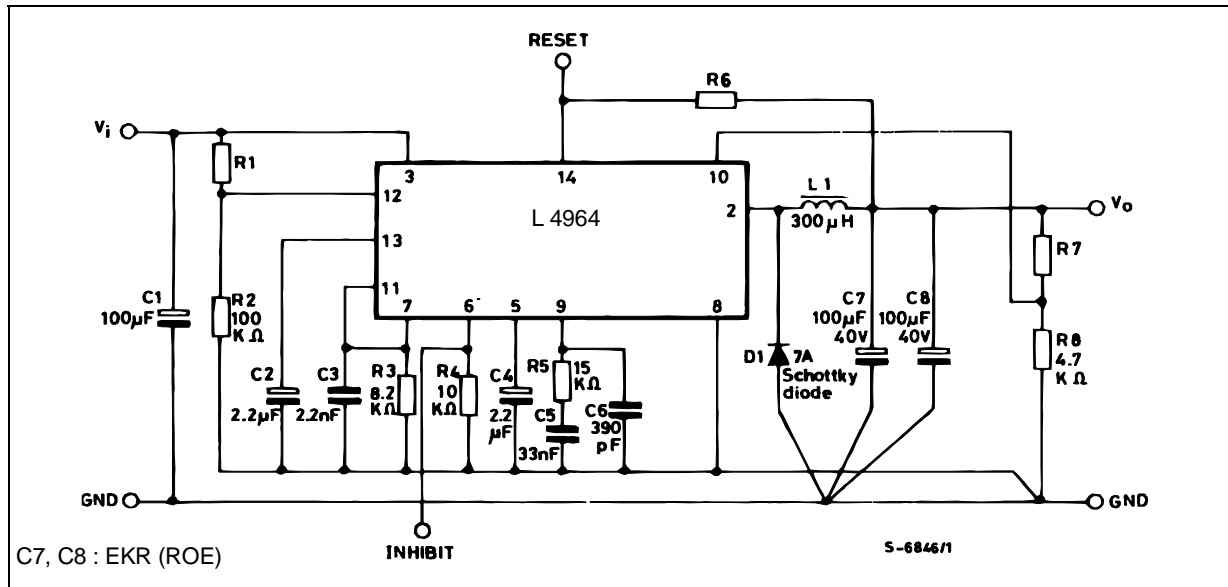
current limiter level. MPP nuclei have very soft saturation characteristics.

$$L = \frac{(V_i - V_o) V_o}{V_i f \Delta I_L}, C = \frac{(V_i - V_o) V_o}{8L f^2 \Delta V_o}$$

$\Delta I_L$  = Inductance current ripple

$\Delta V_o$  = Output ripple voltage

**Figure 13 :** Typical Application Circuit.



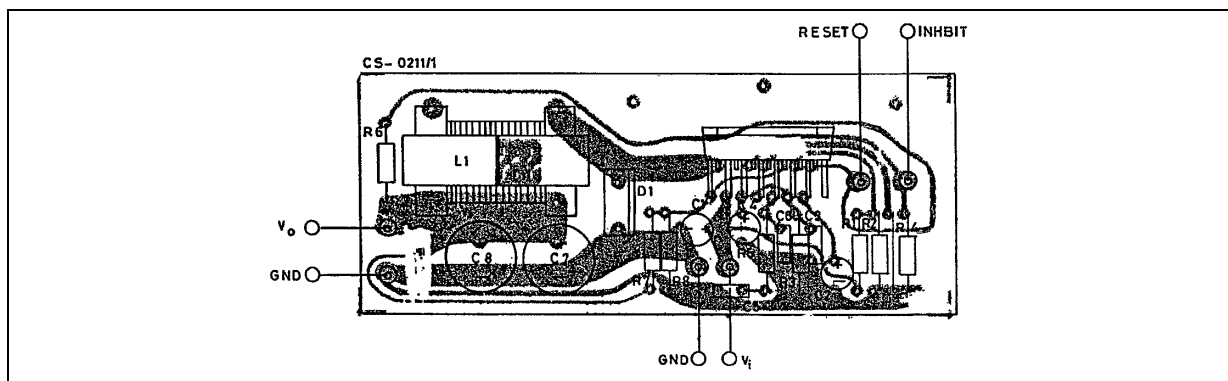
**SUGGESTED INDUCTOR (L1)**

Core Type	No Turns	Wire Gauge (mmm)	Air Gap (mm)
Magnetics 58930 – A2MPP	43	1.0	–
Thomson GUP 20 x 16 x 7	50	0.8	0.7
Siemens EC 35/17/10 (B6633& – G0500 – X127)	40	2 x 0.8	–

VOGT 250 µH Toroidal Coil, Part Number 5730501800

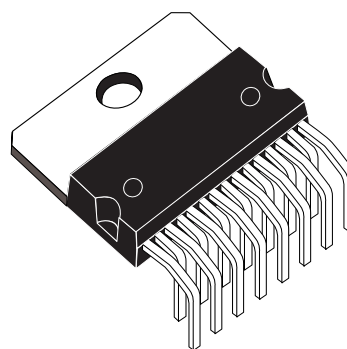
Resistor Values for Standard Output Volt-ages		
V <sub>o</sub>	R8	R7
12 V	4.7 kΩ	6.2 kΩ
15 V	4.7 kΩ	9.1 kΩ
18 V	4.7 kΩ	12 kΩ

**Figure 14 :** P.C. Board and Component Layout of the Circuit of Fig. 13 (1:1 scale)



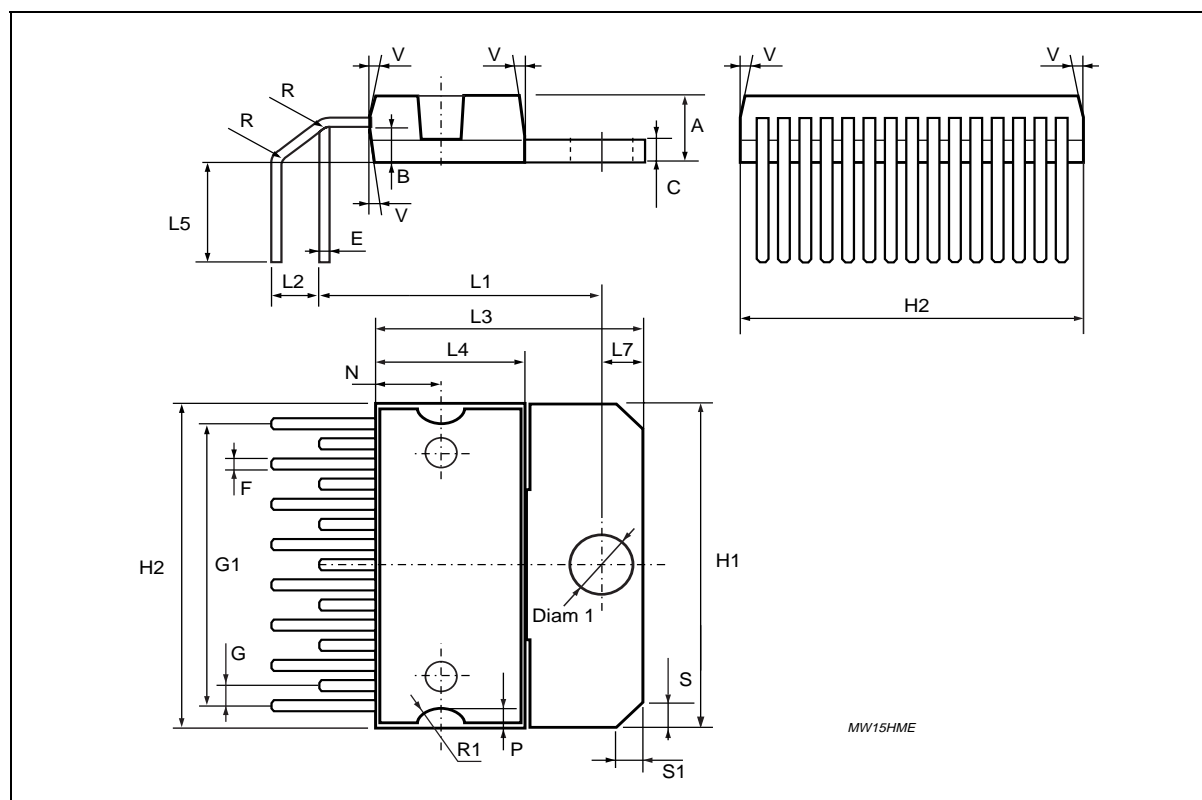
DIM.	mm			inch		
	MIN.	TYP.	MAX.	MIN.	TYP.	MAX.
A			5			0.197
B			2.65			0.104
C			1.6			0.063
E	0.49		0.55	0.019		0.022
F	0.66		0.75	0.026		0.030
G	1.02	1.27	1.52	0.040	0.050	0.060
G1	17.53	17.78	18.03	0.690	0.700	18.030
H1	19.6		20.2	0.772		0.795
H2	19.6		20.2	0.772		0.795
L1	17.8	18	18.2	0.701	0.709	0.717
L2	2.3	2.5	2.8	0.091	0.098	0.110
L3	17.25	17.5	17.75	0.679	0.689	0.699
L4	10.3	10.7	10.9	0.406	0.421	0.429
L5	2.7	3	3.3	0.106	0.118	0.130
L7	2.65		2.9	0.104		0.114
R		1.5			0.059	
S	1.9		2.6	0.075		0.102
S1	1.9		2.6	0.075		0.102
Dia1	3.65		3.85	0.144		0.152

## OUTLINE AND MECHANICAL DATA



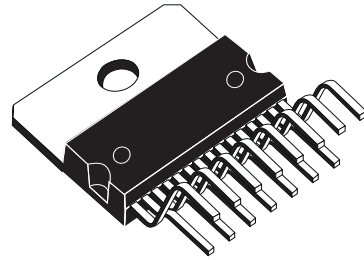
**Multiwatt15 H (Short Leads)**

MUL15V.TBL



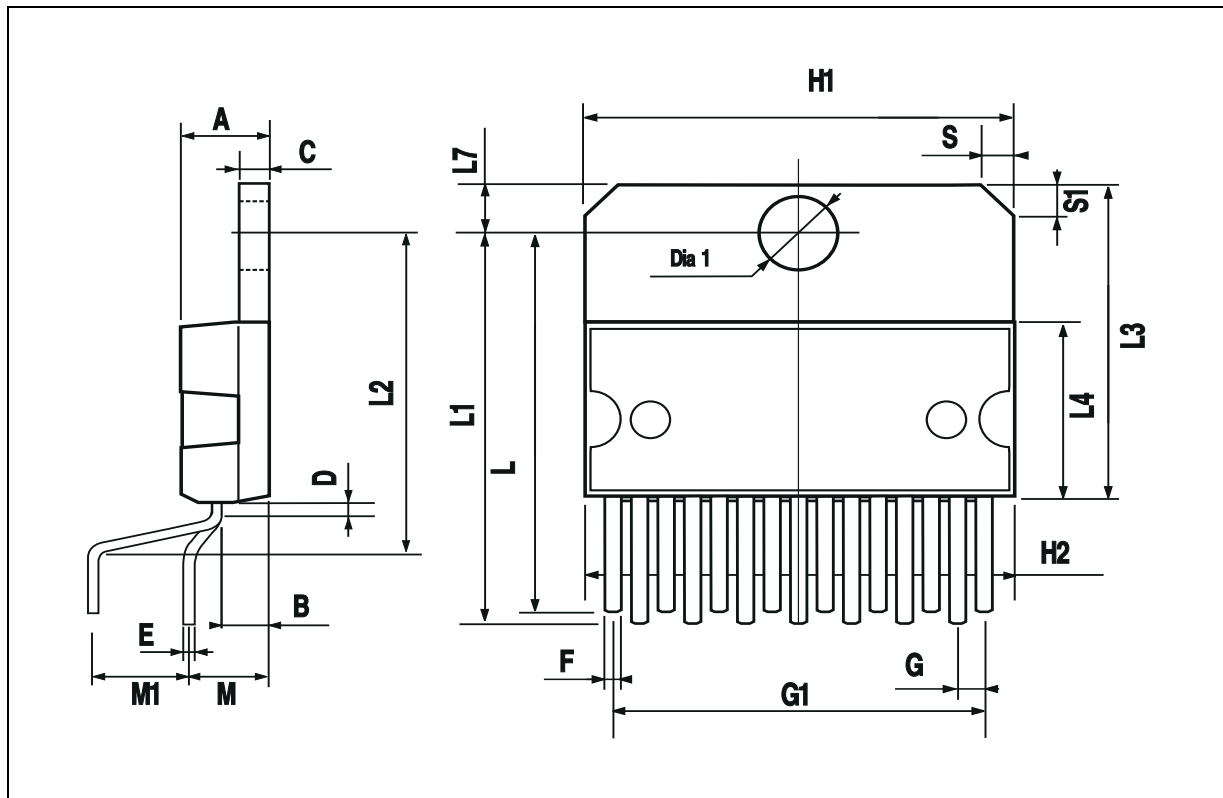
DIM.	mm			inch		
	MIN.	TYP.	MAX.	MIN.	TYP.	MAX.
A			5			0.197
B			2.65			0.104
C			1.6			0.063
D		1			0.039	
E	0.49		0.55	0.019		0.022
F	0.66		0.75	0.026		0.030
G	1.02	1.27	1.52	0.040	0.050	0.060
G1	17.53	17.78	18.03	0.690	0.700	0.710
H1	19.6			0.772		
H2			20.2			0.795
L	21.9	22.2	22.5	0.862	0.874	0.886
L1	21.7	22.1	22.5	0.854	0.870	0.886
L2	17.65		18.1	0.695		0.713
L3	17.25	17.5	17.75	0.679	0.689	0.699
L4	10.3	10.7	10.9	0.406	0.421	0.429
L7	2.65		2.9	0.104		0.114
M	4.25	4.55	4.85	0.167	0.179	0.191
M1	4.63	5.08	5.53	0.182	0.200	0.218
S	1.9		2.6	0.075		0.102
S1	1.9		2.6	0.075		0.102
Dia1	3.65		3.85	0.144		0.152

**OUTLINE AND MECHANICAL DATA**



**Multiwatt15 V**

MULTI15H.TBL



Information furnished is believed to be accurate and reliable. However, STMicroelectronics assumes no responsibility for the consequences of use of such information nor for any infringement of patents or other rights of third parties which may result from its use. No license is granted by implication or otherwise under any patent or patent rights of STMicroelectronics. Specification mentioned in this publication are subject to change without notice. This publication supersedes and replaces all information previously supplied. STMicroelectronics products are not authorized for use as critical components in life support devices or systems without express written approval of STMicroelectronics.

The ST logo is a registered trademark of STMicroelectronics  
© 2003 STMicroelectronics – Printed in Italy – All Rights Reserved  
STMicroelectronics GROUP OF COMPANIES

Australia - Brazil - Canada - China - Finland - France - Germany - Hong Kong - India - Israel - Italy - Japan - Malaysia - Malta - Morocco - Singapore - Spain - Sweden - Switzerland - United Kingdom - United States.

<http://www.st.com>



单击下面可查看定价，库存，交付和生命周期等信息

[>>STMicro\(意法半导体\)](#)