



# STEVAL-IHM026V1

## Motor control and touch sensing demonstration board based on STM8S207RB

Data brief

### Features

- 6 V power supply
- 6 touchkeys implemented
- Motor control connector
- Sensorless or sensed motor control implemented
- Runs in standard or demonstration mode
- On-the-fly motor control parameter tuning
- Equipped with RS-232 connector, I<sup>2</sup>C connector and IrDA transceiver
- SWIM and STice debug support
- 122 x 32 dot-matrix serial interface LCD module
- RoHS compliant

### Description

The STEVAL-IHM026V1 demonstration board integrates a touch sensing (TS) software library and a 3-phase brushless direct-current (BLDC) motor control (MC) software library, allowing the implementation of a 3-phase brushless motor control application in which user control is managed using a few capacitive touch-sensitive controls.

Although not implemented in the demonstration firmware, additional peripherals have been included in the STEVAL-IHM026V1 to increase flexibility for further development.



# 1 Schematic diagrams

The following schematic diagrams for the STEVAL-IMH026V1 are provided in this section:

- Peripherals (*Figure 1*)
- Microcontroller (*Figure 2*)
- Power supply (*Figure 3*)
- MC connector (*Figure 4*)
- Cap sense input (*Figure 5*)

**Figure 1. Peripherals**

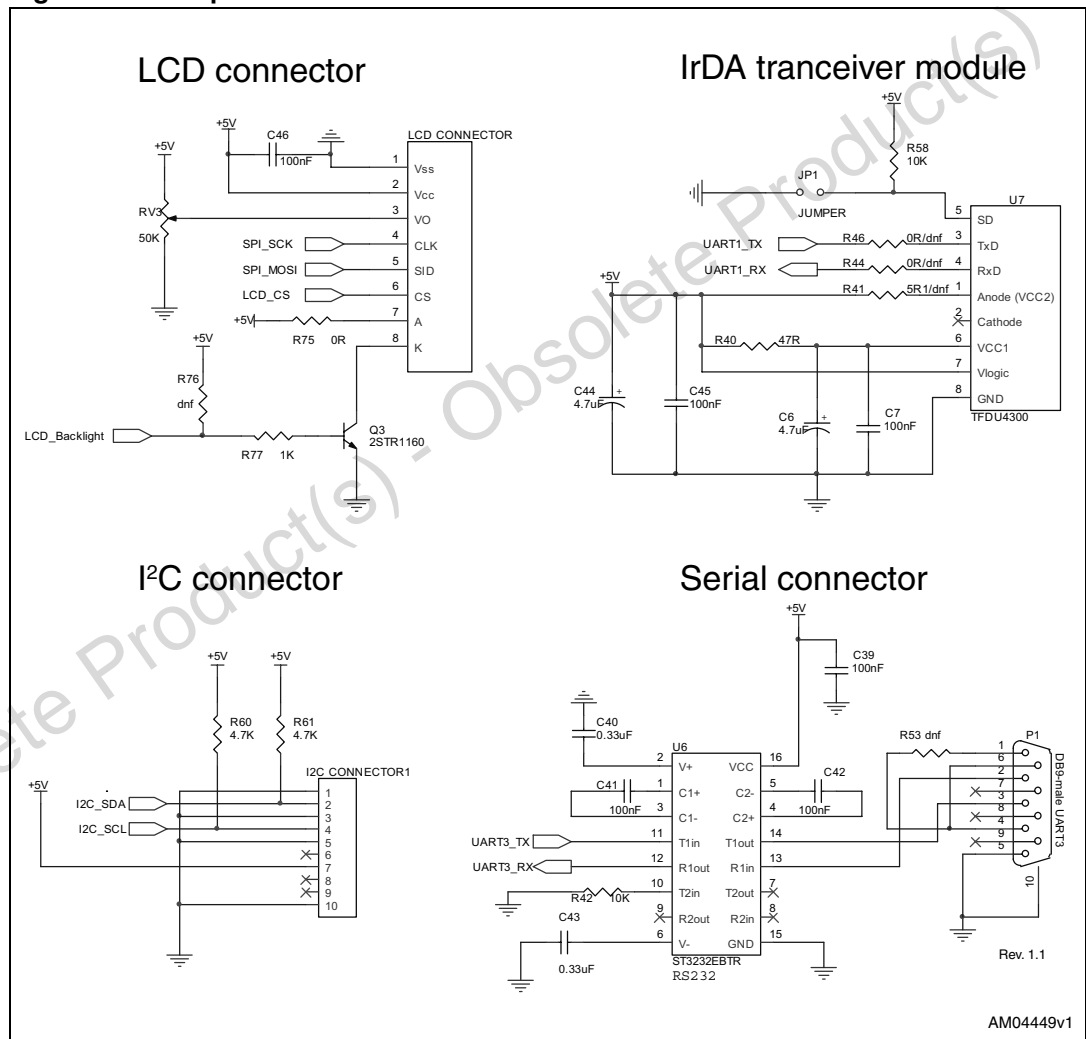

Figure 2. Microcontroller

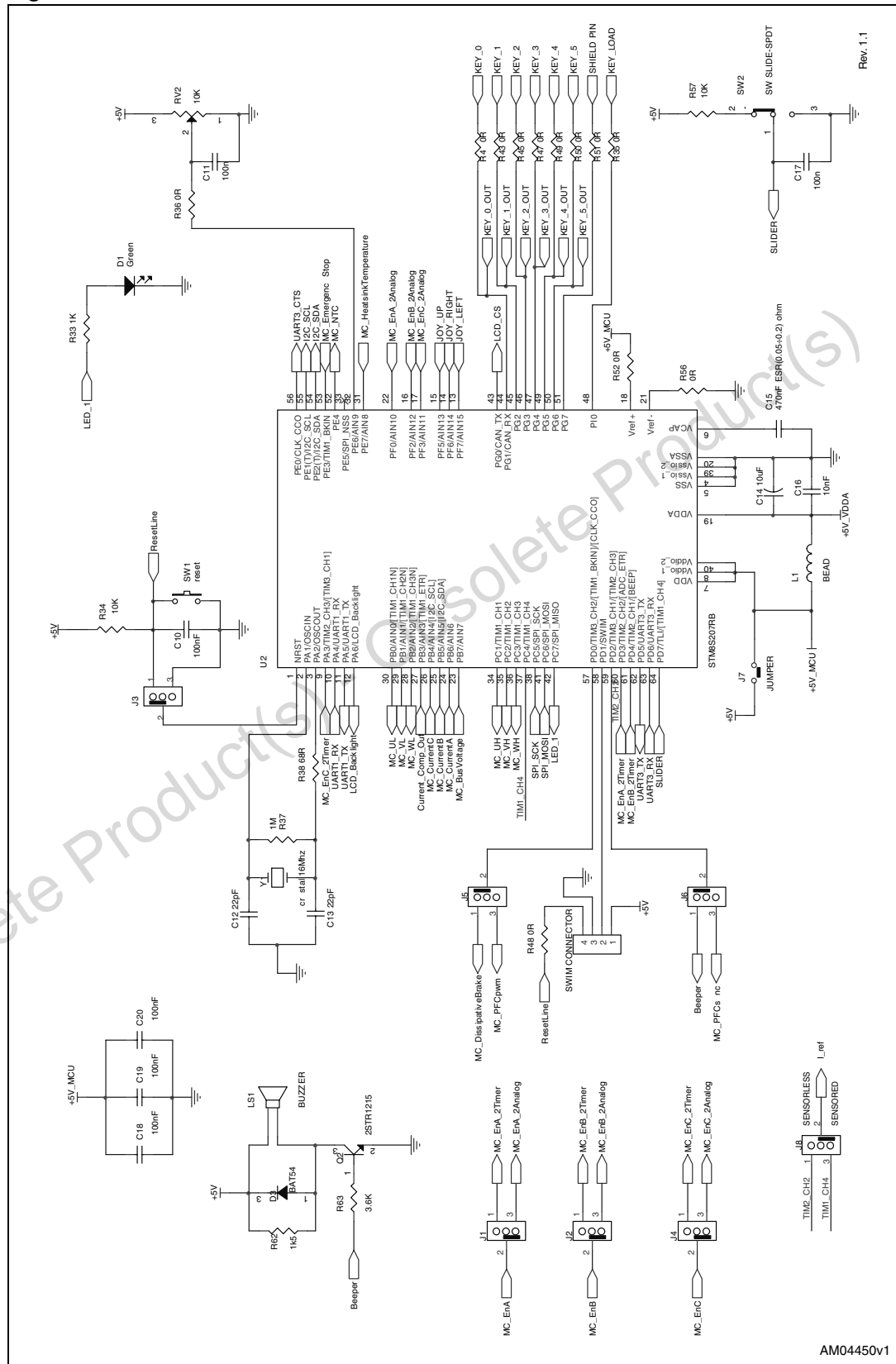

Figure 3. Power supply

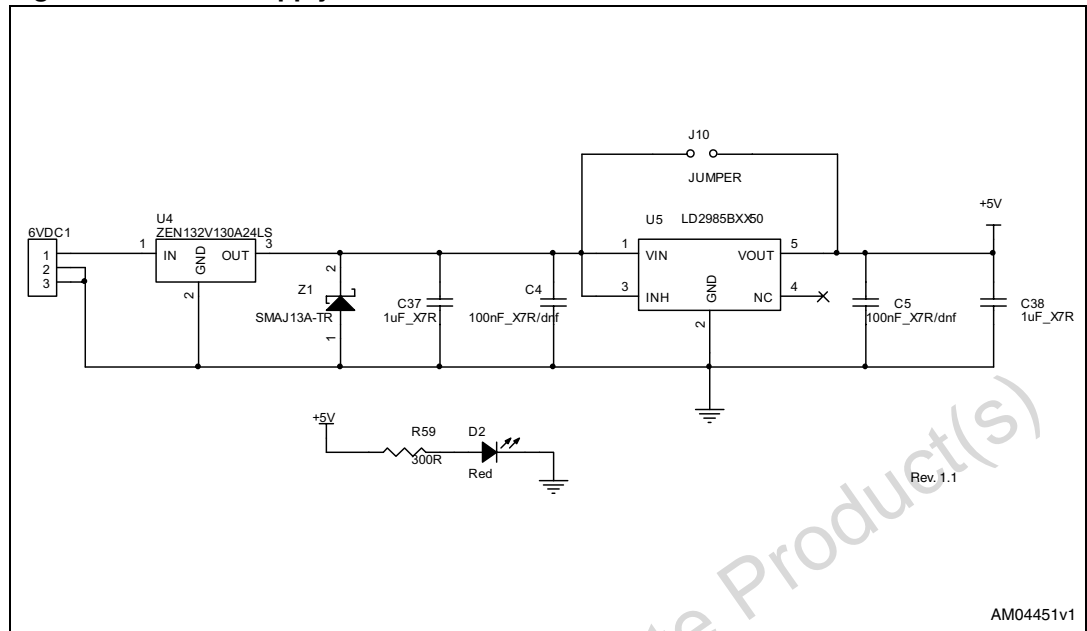

Figure 4. MC connector

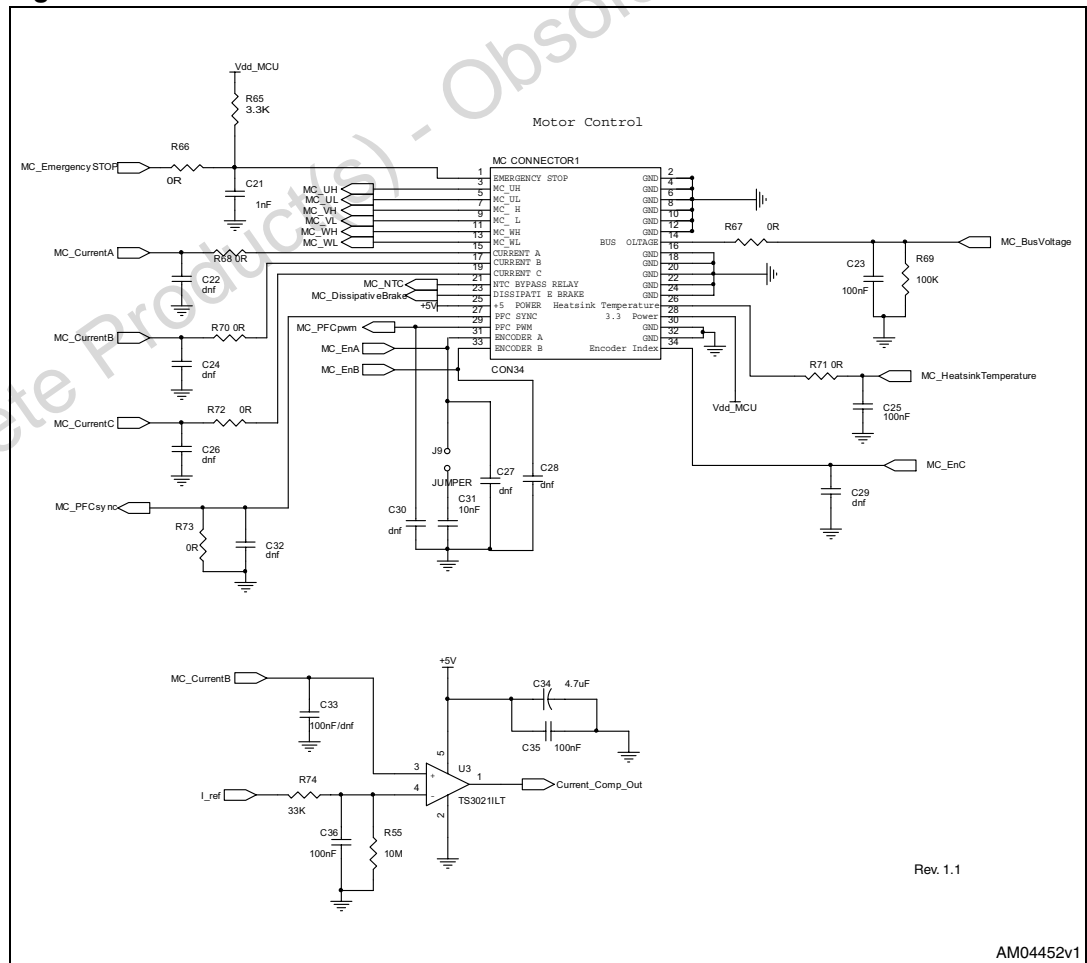
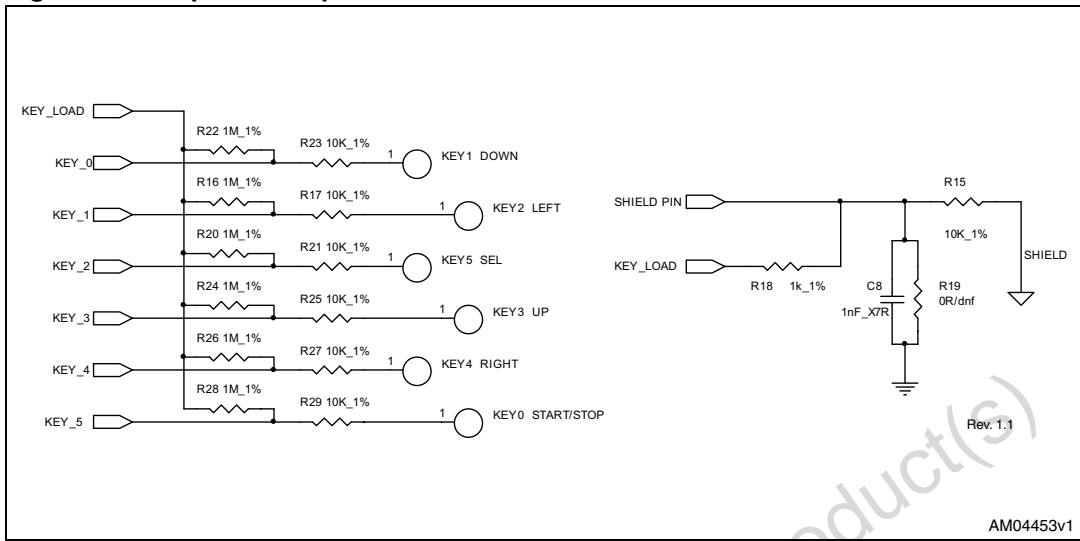

Figure 5. Cap sense input



Obsolete Product(s) - Obsolete Product(s)

## 2 Revision history

Table 1. Document revision history

Date	Revision	Changes
29-Oct-2009	1	Initial release.

Obsolete Product(s) - Obsolete Product(s)

**Please Read Carefully:**

Information in this document is provided solely in connection with ST products. STMicroelectronics NV and its subsidiaries ("ST") reserve the right to make changes, corrections, modifications or improvements, to this document, and the products and services described herein at any time, without notice.

All ST products are sold pursuant to ST's terms and conditions of sale.

Purchasers are solely responsible for the choice, selection and use of the ST products and services described herein, and ST assumes no liability whatsoever relating to the choice, selection or use of the ST products and services described herein.

No license, express or implied, by estoppel or otherwise, to any intellectual property rights is granted under this document. If any part of this document refers to any third party products or services it shall not be deemed a license grant by ST for the use of such third party products or services, or any intellectual property contained therein or considered as a warranty covering the use in any manner whatsoever of such third party products or services or any intellectual property contained therein.

**UNLESS OTHERWISE SET FORTH IN ST'S TERMS AND CONDITIONS OF SALE ST DISCLAIMS ANY EXPRESS OR IMPLIED WARRANTY WITH RESPECT TO THE USE AND/OR SALE OF ST PRODUCTS INCLUDING WITHOUT LIMITATION IMPLIED WARRANTIES OF MERCHANTABILITY, FITNESS FOR A PARTICULAR PURPOSE (AND THEIR EQUIVALENTS UNDER THE LAWS OF ANY JURISDICTION), OR INFRINGEMENT OF ANY PATENT, COPYRIGHT OR OTHER INTELLECTUAL PROPERTY RIGHT.**

**UNLESS EXPRESSLY APPROVED IN WRITING BY AN AUTHORIZED ST REPRESENTATIVE, ST PRODUCTS ARE NOT RECOMMENDED, AUTHORIZED OR WARRANTED FOR USE IN MILITARY, AIR CRAFT, SPACE, LIFE SAVING, OR LIFE SUSTAINING APPLICATIONS, NOR IN PRODUCTS OR SYSTEMS WHERE FAILURE OR MALFUNCTION MAY RESULT IN PERSONAL INJURY, DEATH, OR SEVERE PROPERTY OR ENVIRONMENTAL DAMAGE. ST PRODUCTS WHICH ARE NOT SPECIFIED AS "AUTOMOTIVE GRADE" MAY ONLY BE USED IN AUTOMOTIVE APPLICATIONS AT USER'S OWN RISK.**

Resale of ST products with provisions different from the statements and/or technical features set forth in this document shall immediately void any warranty granted by ST for the ST product or service described herein and shall not create or extend in any manner whatsoever, any liability of ST.

ST and the ST logo are trademarks or registered trademarks of ST in various countries.

Information in this document supersedes and replaces all information previously supplied.

The ST logo is a registered trademark of STMicroelectronics. All other names are the property of their respective owners.

© 2009 STMicroelectronics - All rights reserved

STMicroelectronics group of companies

Australia - Belgium - Brazil - Canada - China - Czech Republic - Finland - France - Germany - Hong Kong - India - Israel - Italy - Japan - Malaysia - Malta - Morocco - Philippines - Singapore - Spain - Sweden - Switzerland - United Kingdom - United States of America

[www.st.com](http://www.st.com)



单击下面可查看定价，库存，交付和生命周期等信息

[>>STMicro\(意法半导体\)](#)