



STx25NM60ND

N-channel 600 V, 0.13 Ω , 21 A FDmesh™ II Power MOSFET
(with fast diode) in D²PAK, TO-220FP, TO-220, TO-247

Features

| Type | V _{DSS} @ T _{JMAX} | R _{DS(on)} max | I _D |
|-------------|---|-------------------------|---------------------|
| STB25NM60ND | 650 V | 0.16 Ω | 21 A |
| STF25NM60ND | | | 21 A ⁽¹⁾ |
| STP25NM60ND | | | 21 A |
| STW25NM60ND | | | 21 A |

- Limited only by maximum temperature allowed
- The worldwide best R_{DS(on)}*area amongst the fast recovery diode devices
 - 100% avalanche tested
 - Low input capacitance and gate charge
 - Low gate input resistance
 - Extremely high dv/dt and avalanche capabilities

Application

- Switching applications

Description

These FDmesh™ II Power MOSFETs with intrinsic fast-recovery body diode are produced using the second generation of MDmesh™ technology. Utilizing a new strip-layout vertical structure, these revolutionary devices feature extremely low on-resistance and superior switching performance. They are ideal for bridge topologies and ZVS phase-shift converters.

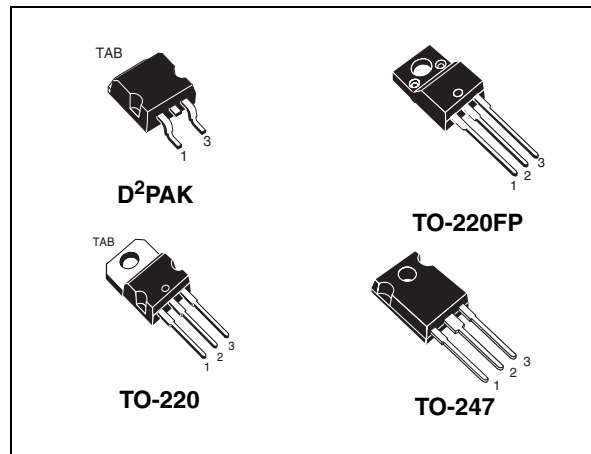

Figure 1. Internal schematic diagram

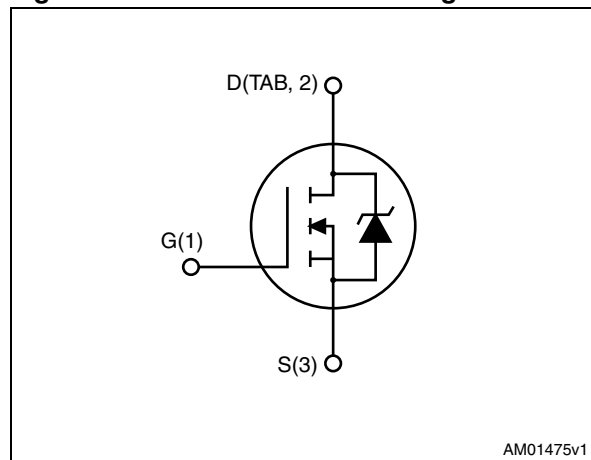

Table 1. Device summary

| Order codes | Marking | Package | Packaging |
|-------------|----------|--------------------|---------------|
| STB25NM60ND | 25NM60ND | D ² PAK | Tape and reel |
| STF25NM60ND | 25NM60ND | TO-220FP | Tube |
| STP25NM60ND | 25NM60ND | TO-220 | Tube |
| STW25NM60ND | 25NM60ND | TO-247 | Tube |

Contents

| | | |
|----------|---|-----------|
| 1 | Electrical ratings | 3 |
| 2 | Electrical characteristics | 4 |
| 2.1 | Electrical characteristics (curves) | 6 |
| 3 | Test circuits | 9 |
| 4 | Package mechanical data | 10 |
| 5 | Packing mechanical data | 18 |
| 6 | Revision history | 20 |

1 Electrical ratings

Table 2. Absolute maximum ratings

| Symbol | Parameter | Value | | Unit |
|--------------------------------|--|------------------------------------|-------------------|------|
| | | D ² PAK, TO-220, TO-247 | TO-220FP | |
| V _{DS} | Drain-source voltage | 600 | | V |
| V _{GS} | Gate-source voltage | ±25 | | V |
| I _D | Drain current (continuous) at T _C = 25 °C | 21 | 21 ⁽¹⁾ | A |
| I _D | Drain current (continuous) at T _C = 100 °C | 13 | 13 ⁽¹⁾ | A |
| I _{DM} ⁽²⁾ | Drain current (pulsed) | 84 | 84(1) | A |
| P _{TOT} | Total dissipation at T _C = 25 °C | 160 | 40 | W |
| dv/dt ⁽³⁾ | Peak diode recovery voltage slope | 40 | | V/ns |
| V _{iso} | Insulation withstand voltage (RMS) from all three leads to external heat sink (t=1 s; T _C =25 °C) | | 2500 | V |
| T _{stg} | Storage temperature | -55 to 150 | | °C |
| T _J | Max. operating junction temperature | 150 | | °C |

- Limited only by maximum temperature allowed
- Pulse width limited by safe operating area
- I_{SD} ≤ 21 A, di/dt ≤ 600 A/μs, V_{DD} = 80% V_{(BR)DSS}

Table 3. Thermal data

| Symbol | Parameter | D ² PAK | TO-220FP | TO-220 | TO-247 | Unit |
|-------------------------------------|---|--------------------|----------|--------|--------|------|
| R _{thj-case} | Thermal resistance junction-case max | 0.78 | 3.1 | 0.78 | | °C/W |
| R _{thj-amb} | Thermal resistance junction-ambient max | | 62.5 | | 50 | °C/W |
| R _{thj-pcb} ⁽¹⁾ | Thermal resistance junction-ambient max | 30 | | | | °C/W |

- When mounted on 1inch² FR-4 board, 2 oz Cu

Table 4. Avalanche characteristics

| Symbol | Parameter | Max value | Unit |
|-----------------|--|-----------|------|
| I _{AS} | Avalanche current, repetitive or not-repetitive (pulse width limited by T _J max) | 10 | A |
| E _{AS} | Single pulse avalanche energy (starting T _J = 25 °C, I _D = I _{AS} , V _{DD} = 50 V) | 850 | mJ |

2 Electrical characteristics

($T_{CASE}=25\text{ °C}$ unless otherwise specified).

Table 5. On/off states

| Symbol | Parameter | Test conditions | Value | | | Unit |
|---------------|--|--|-------|------|-----------|--------------------------------|
| | | | Min. | Typ. | Max. | |
| $V_{(BR)DSS}$ | Drain-source breakdown voltage | $I_D = 1\text{ mA}, V_{GS} = 0$ | 600 | | | V |
| $dv/dt^{(1)}$ | Drain source voltage slope | $V_{DD} = 480\text{ V}, I_D = 21\text{ A}, V_{GS} = 10\text{ V}$ | 48 | | | V/ns |
| I_{DSS} | Zero gate voltage drain current ($V_{GS} = 0$) | $V_{DS} = 600\text{ V}$ $V_{DS} = 600\text{ V} @ T_C = 125\text{ °C}$ | | | 1 100 | μA μA |
| I_{GSS} | Gate-body leakage current ($V_{DS} = 0$) | $V_{GS} = \pm 20\text{ V}$ | | | ± 100 | nA |
| $V_{GS(th)}$ | Gate threshold voltage | $V_{DS} = V_{GS}, I_D = 250\text{ }\mu\text{A}$ | 3 | 4 | 5 | V |
| $R_{DS(on)}$ | Static drain-source on resistance | $V_{GS} = 10\text{ V}, I_D = 10.5\text{ A}$ | | 0.13 | 0.16 | Ω |

1. Characteristic value at turn off on inductive load.

Table 6. Dynamic

| Symbol | Parameter | Test conditions | Min. | Typ. | Max. | Unit |
|---|---|--|------|----------------------|------|----------------------|
| $g_{fs}^{(1)}$ | Forward transconductance | $V_{DS} = 15\text{ V}, I_D = 10.5\text{ A}$ | - | 17 | - | S |
| C_{iss} C_{oss} C_{rss} | Input capacitance Output capacitance Reverse transfer capacitance | $V_{DS} = 50\text{ V}, f = 1\text{ MHz}, V_{GS} = 0$ | - | 2400 150 15 | - | pF pF pF |
| $C_{oss\text{ eq.}}^{(2)}$ | Equivalent output capacitance | $V_{GS} = 0, V_{DS} = 0\text{ to }480\text{ V}$ | - | 320 | - | pF |
| $t_{d(on)}$ t_r $t_{d(off)}$ t_f | Turn-on delay time Rise time Turn-off delay time Fall time | $V_{DD} = 300\text{ V}, I_D = 10.5\text{ A}$ $R_G = 4.7\text{ }\Omega, V_{GS} = 10\text{ V}$ (see Figure 23), (see Figure 18) | - | 60 30 50 40 | - | ns ns ns ns |
| Q_g Q_{gs} Q_{gd} | Total gate charge Gate-source charge Gate-drain charge | $V_{DD} = 480\text{ V}, I_D = 21\text{ A}, V_{GS} = 10\text{ V},$ (see Figure 19) | - | 80 15 40 | - | nC nC nC |
| R_g | Gate input resistance | $f=1\text{ MHz}$ gate DC bias=0 Test signal level = 20 mV open drain | - | 1.6 | - | Ω |

1. Pulsed: pulse duration=300 μs , duty cycle 1.5%

2. $C_{oss\text{ eq.}}$ is defined as a constant equivalent capacitance giving the same charging time as C_{oss} when V_{DS} increases from 0 to 80% V_{DSS}

Table 7. Source drain diode

| Symbol | Parameter | Test conditions | Min. | Typ. | Max. | Unit |
|-----------------|-------------------------------|---|------|------|------|---------------|
| I_{SD} | Source-drain current | | - | | 21 | A |
| $I_{SDM}^{(1)}$ | Source-drain current (pulsed) | | - | | 84 | A |
| $V_{SD}^{(2)}$ | Forward on voltage | $I_{SD} = 21\text{ A}, V_{GS} = 0$ | - | | 1.3 | V |
| t_{rr} | Reverse recovery time | $I_{SD} = 21\text{ A}, V_{DD} = 60\text{ V}$ $di/dt = 100\text{ A}/\mu\text{s}$ <i>(see Figure 20)</i> | - | 160 | | ns |
| Q_{rr} | Reverse recovery charge | | | 1 | | μC |
| I_{RRM} | Reverse recovery current | | | 15 | | A |
| t_{rr} | Reverse recovery time | $I_{SD} = 21\text{ A}, V_{DD} = 60\text{ V}$ $di/dt = 100\text{ A}/\mu\text{s}$, $T_J = 150\text{ }^\circ\text{C}$ <i>(see Figure 20)</i> | - | 230 | | ns |
| Q_{rr} | Reverse recovery charge | | | 2 | | μC |
| I_{RRM} | Reverse recovery current | | | 19 | | A |

1. Pulse width limited by safe operating area
2. Pulsed: Pulse duration = 300 μs , duty cycle 1.5%.

2.1 Electrical characteristics (curves)

Figure 2. Safe operating area for D²PAK and TO-220

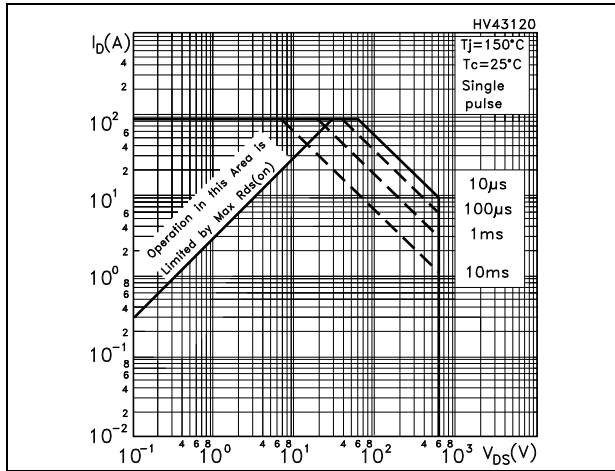

Figure 3. Thermal impedance for D²PAK and TO-220

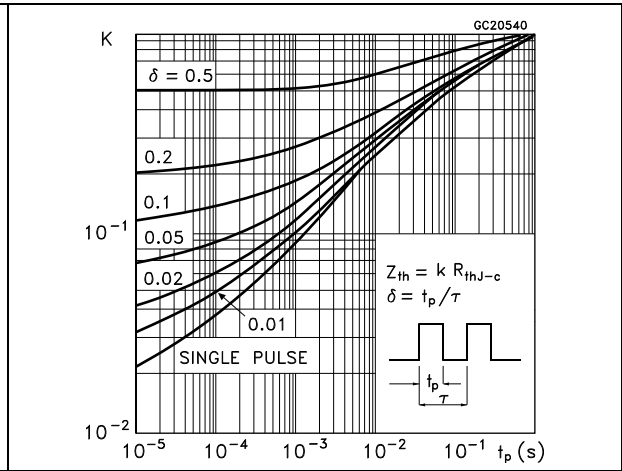

Figure 4. Safe operating area for TO-220FP

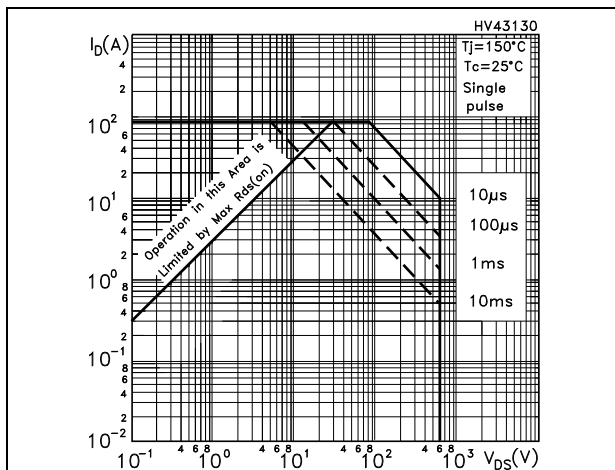

Figure 5. Thermal impedance for TO-220FP

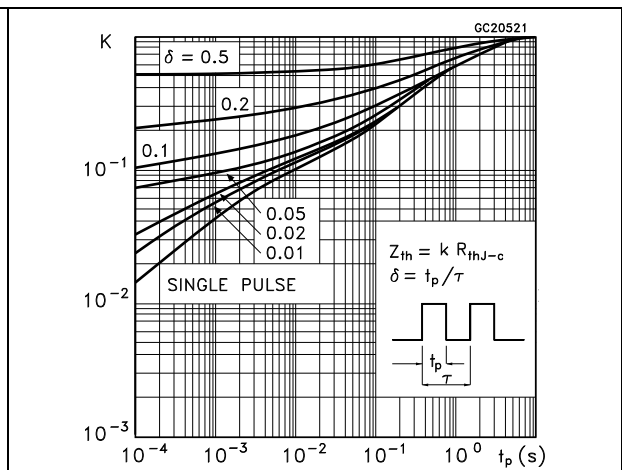

Figure 6. Safe operating area for TO-247

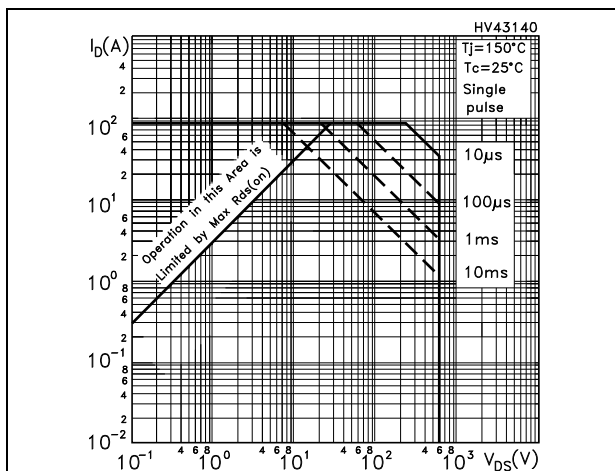

Figure 7. Thermal impedance for TO-247

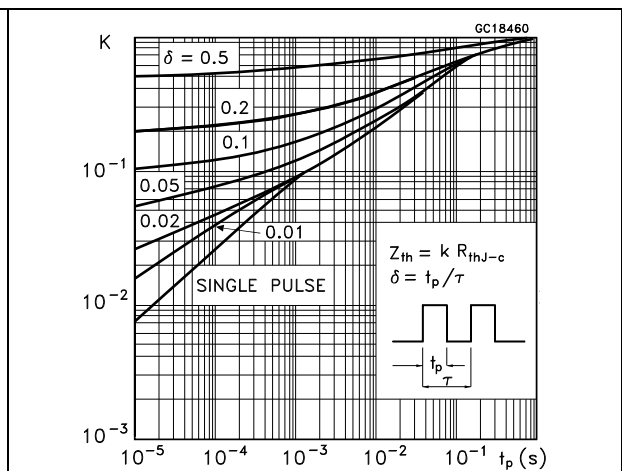

Figure 8. Output characteristics

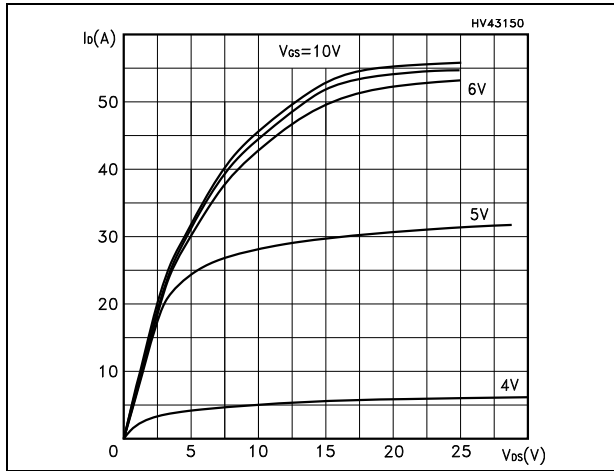

Figure 9. Transfer characteristics

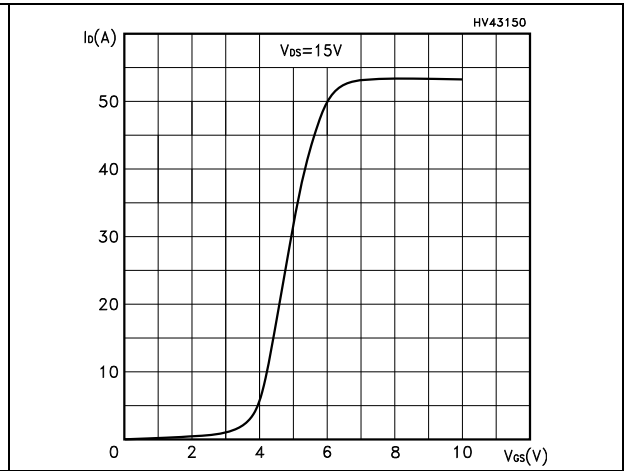

Figure 10. Transconductance

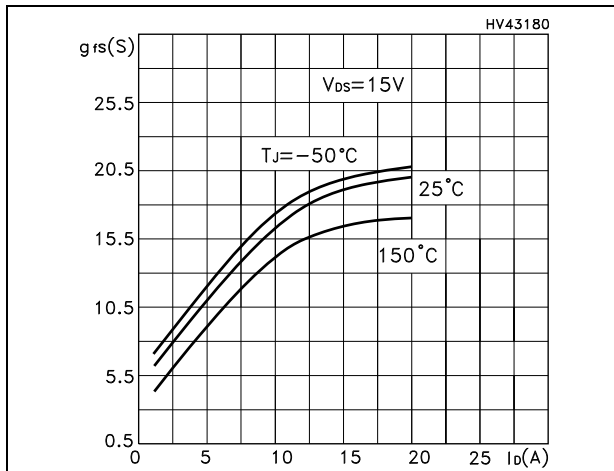

Figure 11. Static drain-source on resistance

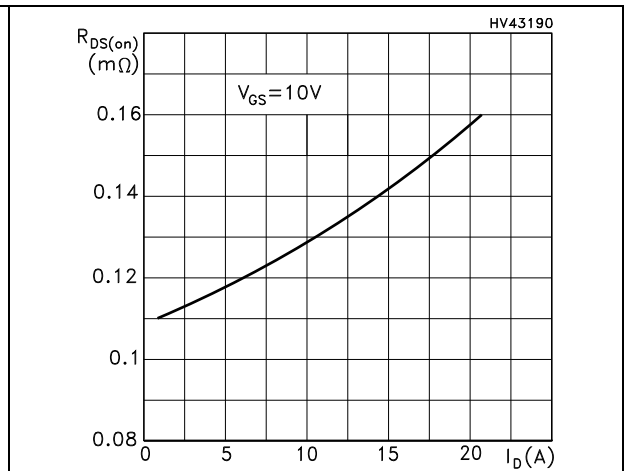

Figure 12. Gate charge vs gate-source voltage Figure 13. Capacitance variations

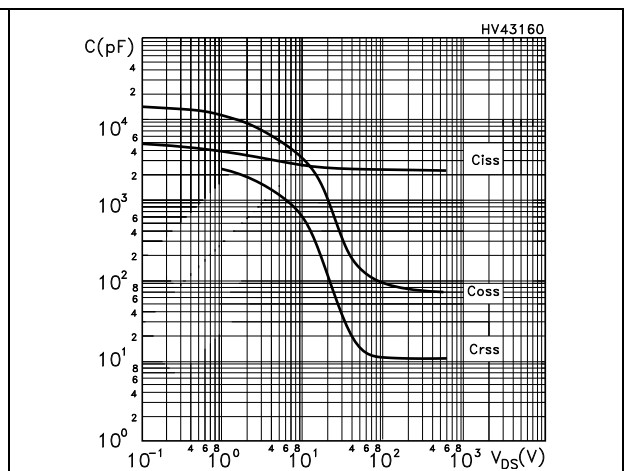
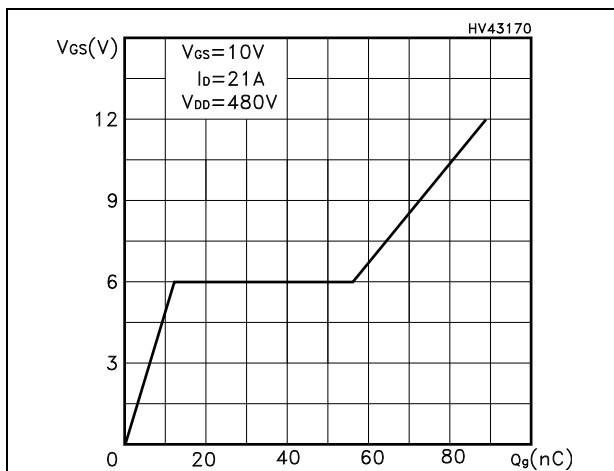

Figure 14. Normalized gate threshold voltage vs temperature

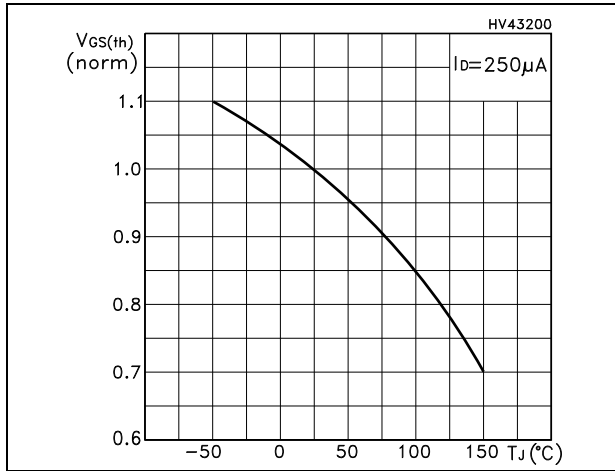

Figure 15. Normalized on resistance vs temperature

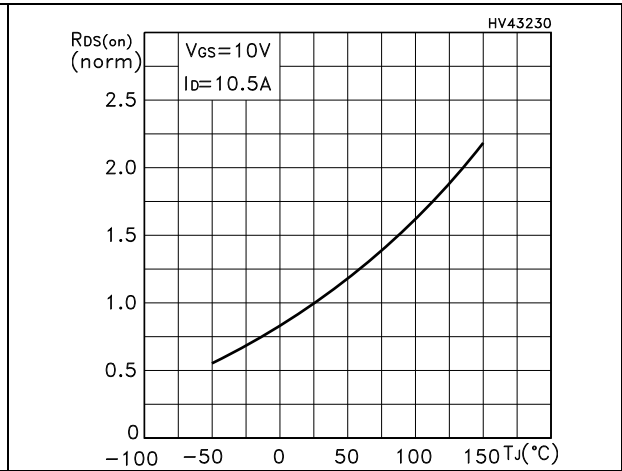

Figure 16. Source-drain diode forward characteristics

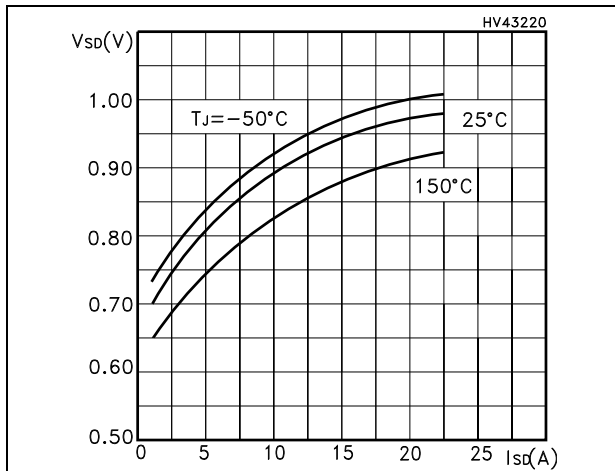
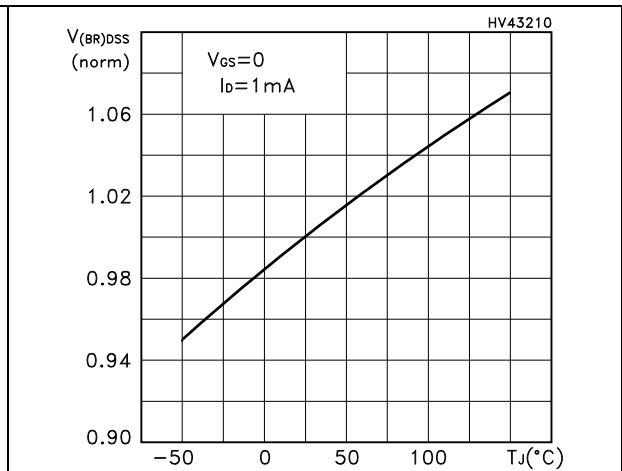

Figure 17. Normalized B_VDSS vs temperature



3 Test circuits

Figure 18. Switching times test circuit for resistive load

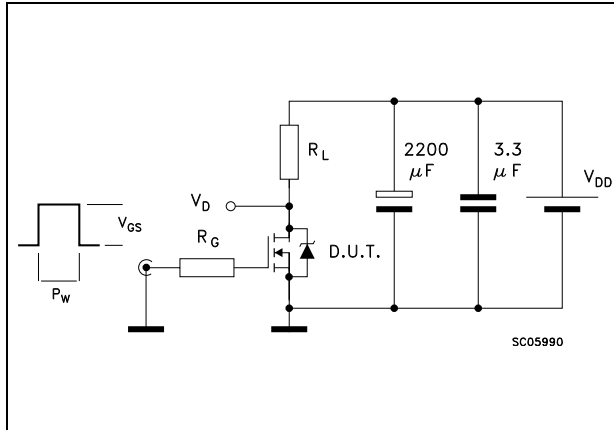

Figure 19. Gate charge test circuit

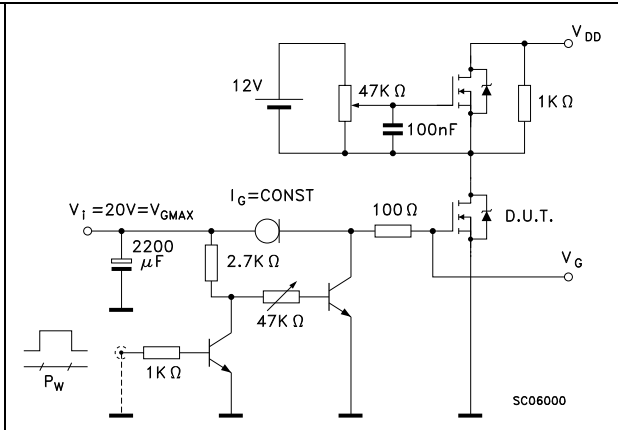

Figure 20. Test circuit for inductive load switching and diode recovery times

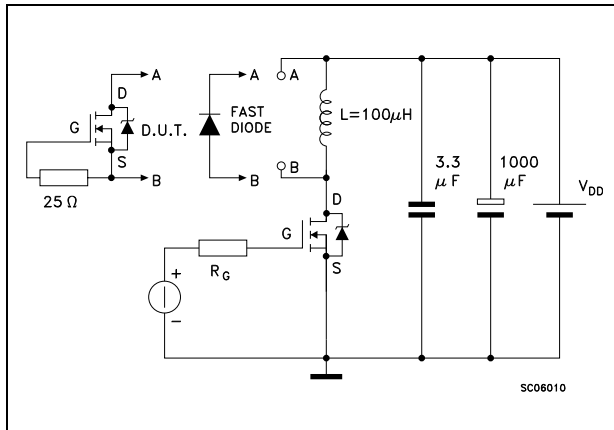

Figure 21. Unclamped inductive load test circuit

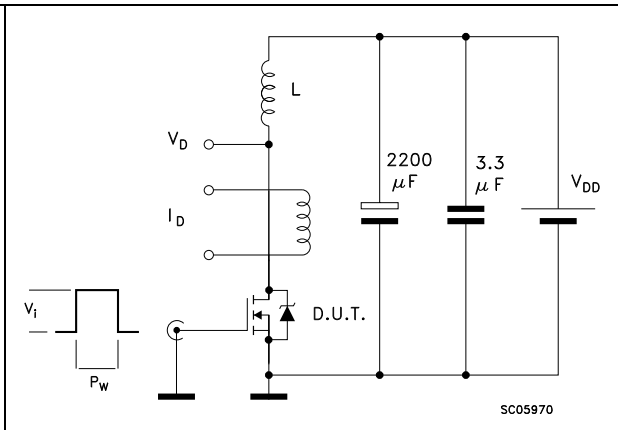

Figure 22. Unclamped inductive waveform

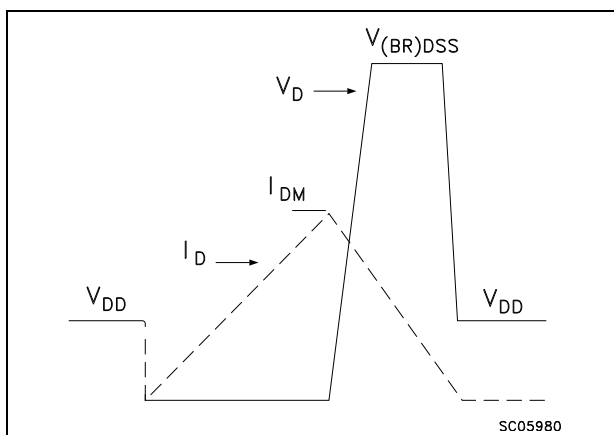
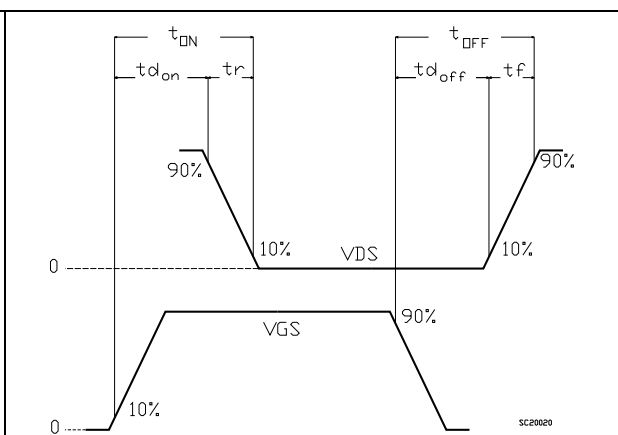

Figure 23. Switching time waveform



4 Package mechanical data

In order to meet environmental requirements, ST offers these devices in different grades of ECOPACK® packages, depending on their level of environmental compliance. ECOPACK® specifications, grade definitions and product status are available at: www.st.com. ECOPACK is an ST trademark.

Table 8. D²PAK (TO-263) mechanical data

| Dim. | mm | | |
|------|------|------|-------|
| | Min. | Typ. | Max. |
| A | 4.40 | | 4.60 |
| A1 | 0.03 | | 0.23 |
| b | 0.70 | | 0.93 |
| b2 | 1.14 | | 1.70 |
| c | 0.45 | | 0.60 |
| c2 | 1.23 | | 1.36 |
| D | 8.95 | | 9.35 |
| D1 | 7.50 | | |
| E | 10 | | 10.40 |
| E1 | 8.50 | | |
| e | | 2.54 | |
| e1 | 4.88 | | 5.28 |
| H | 15 | | 15.85 |
| J1 | 2.49 | | 2.69 |
| L | 2.29 | | 2.79 |
| L1 | 1.27 | | 1.40 |
| L2 | 1.30 | | 1.75 |
| R | | 0.4 | |
| V2 | 0° | | 8° |

Figure 24. D²PAK (TO-263) drawing



Figure 25. D²PAK footprint^(a)



a. All dimension are in millimeters

Table 9. TO-220FP mechanical data

| Dim. | mm | | |
|------|------|------|------|
| | Min. | Typ. | Max. |
| A | 4.4 | | 4.6 |
| B | 2.5 | | 2.7 |
| D | 2.5 | | 2.75 |
| E | 0.45 | | 0.7 |
| F | 0.75 | | 1 |
| F1 | 1.15 | | 1.70 |
| F2 | 1.15 | | 1.70 |
| G | 4.95 | | 5.2 |
| G1 | 2.4 | | 2.7 |
| H | 10 | | 10.4 |
| L2 | | 16 | |
| L3 | 28.6 | | 30.6 |
| L4 | 9.8 | | 10.6 |
| L5 | 2.9 | | 3.6 |
| L6 | 15.9 | | 16.4 |
| L7 | 9 | | 9.3 |
| Dia | 3 | | 3.2 |

TO-220FP drawing

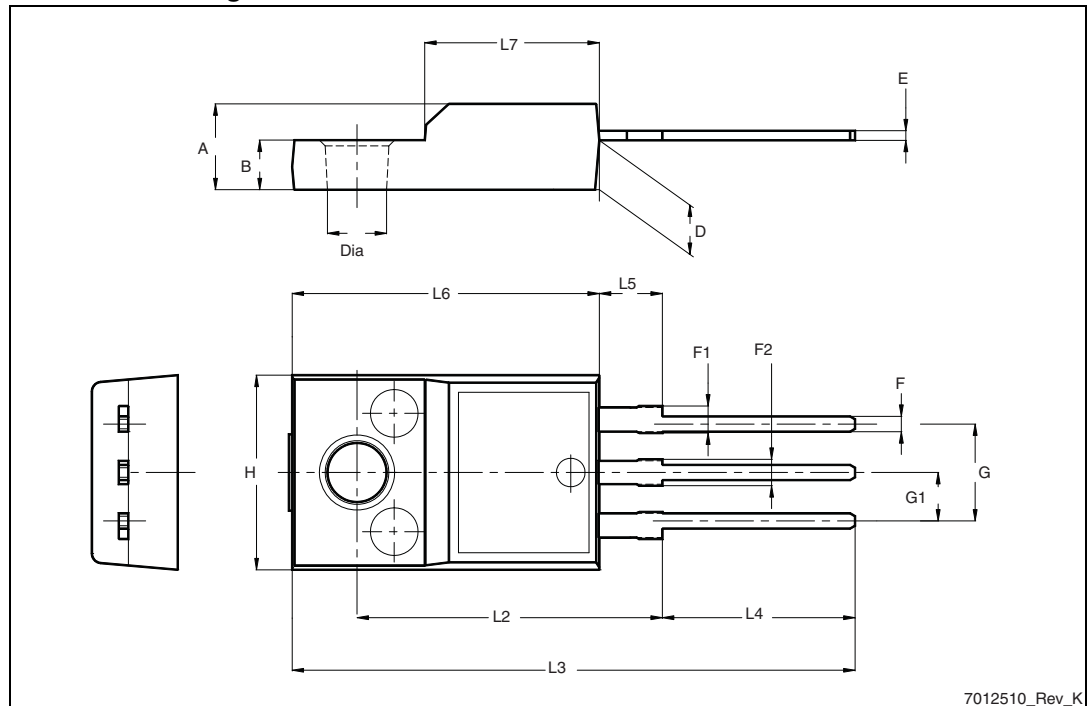

Table 10. TO-220 type A mechanical data

| Dim. | mm | | |
|------|-------|-------|-------|
| | Min. | Typ. | Max. |
| A | 4.40 | | 4.60 |
| b | 0.61 | | 0.88 |
| b1 | 1.14 | | 1.70 |
| c | 0.48 | | 0.70 |
| D | 15.25 | | 15.75 |
| D1 | | 1.27 | |
| E | 10 | | 10.40 |
| e | 2.40 | | 2.70 |
| e1 | 4.95 | | 5.15 |
| F | 1.23 | | 1.32 |
| H1 | 6.20 | | 6.60 |
| J1 | 2.40 | | 2.72 |
| L | 13 | | 14 |
| L1 | 3.50 | | 3.93 |
| L20 | | 16.40 | |
| L30 | | 28.90 | |
| ØP | 3.75 | | 3.85 |
| Q | 2.65 | | 2.95 |

Figure 26. TO-220 type A drawing

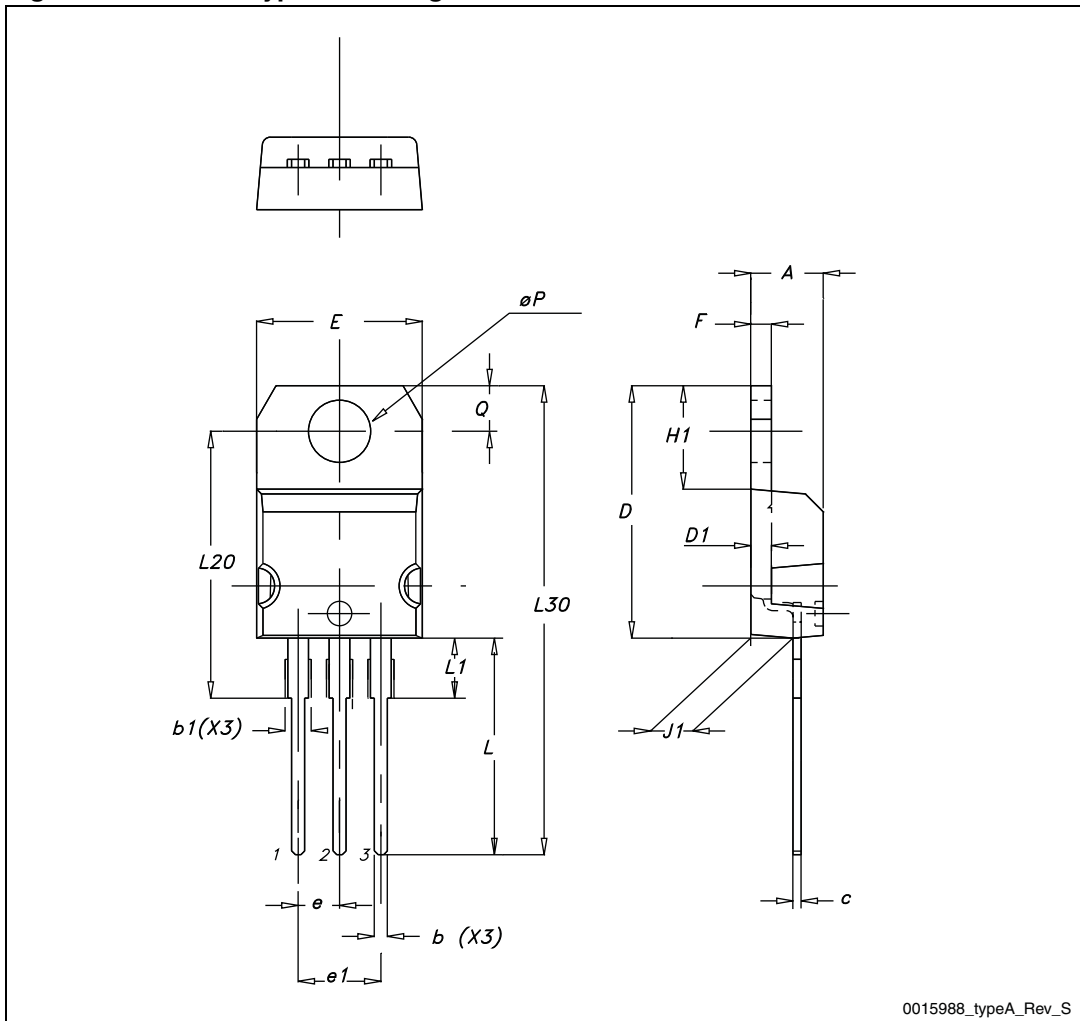
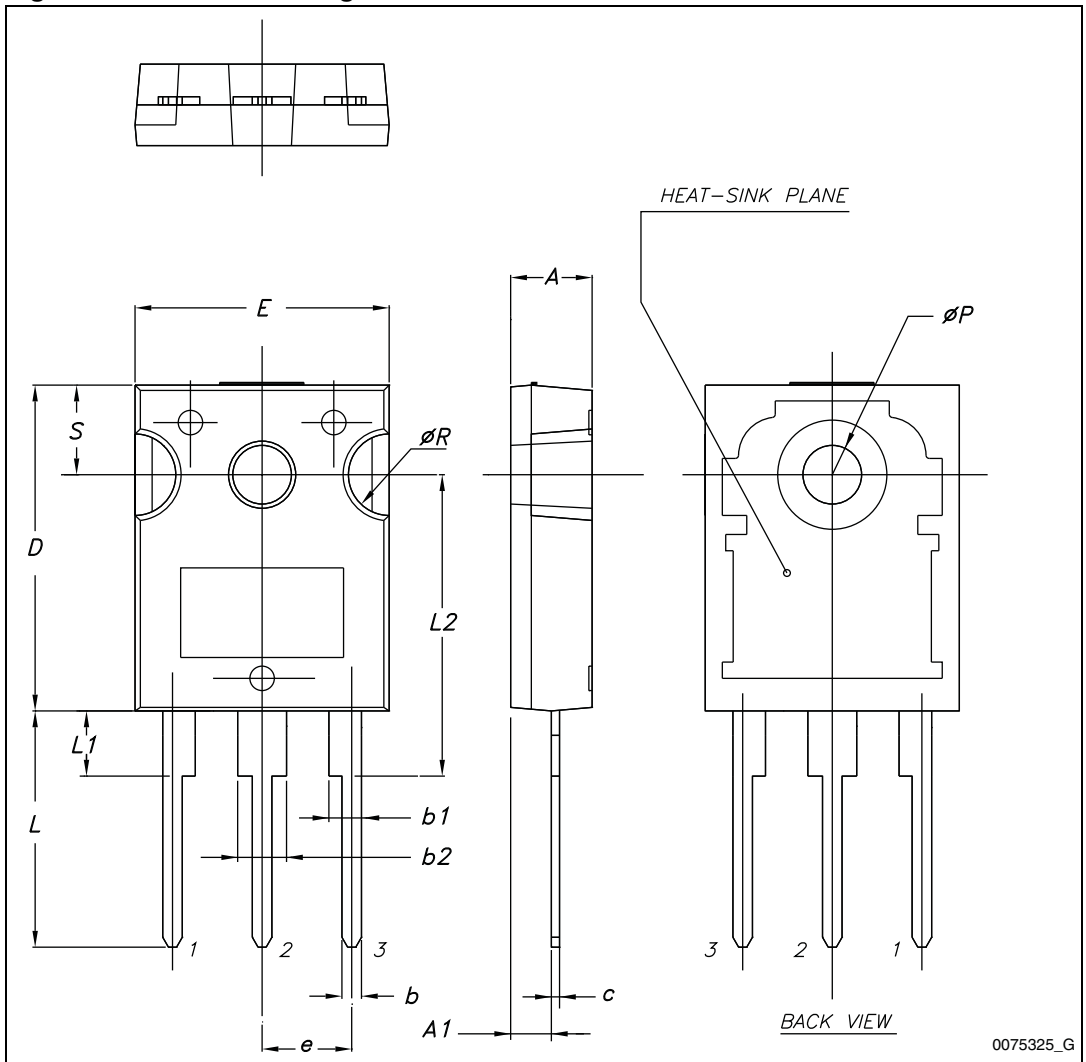

Table 11. TO-247 mechanical data

| Dim. | mm. | | |
|------|-------|-------|-------|
| | Min. | Typ. | Max. |
| A | 4.85 | | 5.15 |
| A1 | 2.20 | | 2.60 |
| b | 1.0 | | 1.40 |
| b1 | 2.0 | | 2.40 |
| b2 | 3.0 | | 3.40 |
| c | 0.40 | | 0.80 |
| D | 19.85 | | 20.15 |
| E | 15.45 | | 15.75 |
| e | 5.30 | 5.45 | 5.60 |
| L | 14.20 | | 14.80 |
| L1 | 3.70 | | 4.30 |
| L2 | | 18.50 | |
| ØP | 3.55 | | 3.65 |
| ØR | 4.50 | | 5.50 |
| S | 5.30 | 5.50 | 5.70 |

Figure 27. TO-247 drawing



0075325_G

5 Packing mechanical data

Table 12. D²PAK (TO-263) tape and reel mechanical data

| Tape | | | Reel | | |
|------|------|------|----------|------|------|
| Dim. | mm | | Dim. | mm | |
| | Min. | Max. | | Min. | Max. |
| A0 | 10.5 | 10.7 | A | | 330 |
| B0 | 15.7 | 15.9 | B | 1.5 | |
| D | 1.5 | 1.6 | C | 12.8 | 13.2 |
| D1 | 1.59 | 1.61 | D | 20.2 | |
| E | 1.65 | 1.85 | G | 24.4 | 26.4 |
| F | 11.4 | 11.6 | N | 100 | |
| K0 | 4.8 | 5.0 | T | | 30.4 |
| P0 | 3.9 | 4.1 | | | |
| P1 | 11.9 | 12.1 | Base qty | | 1000 |
| P2 | 1.9 | 2.1 | Bulk qty | | 1000 |
| R | 50 | | | | |
| T | 0.25 | 0.35 | | | |
| W | 23.7 | 24.3 | | | |

Figure 28. Tape

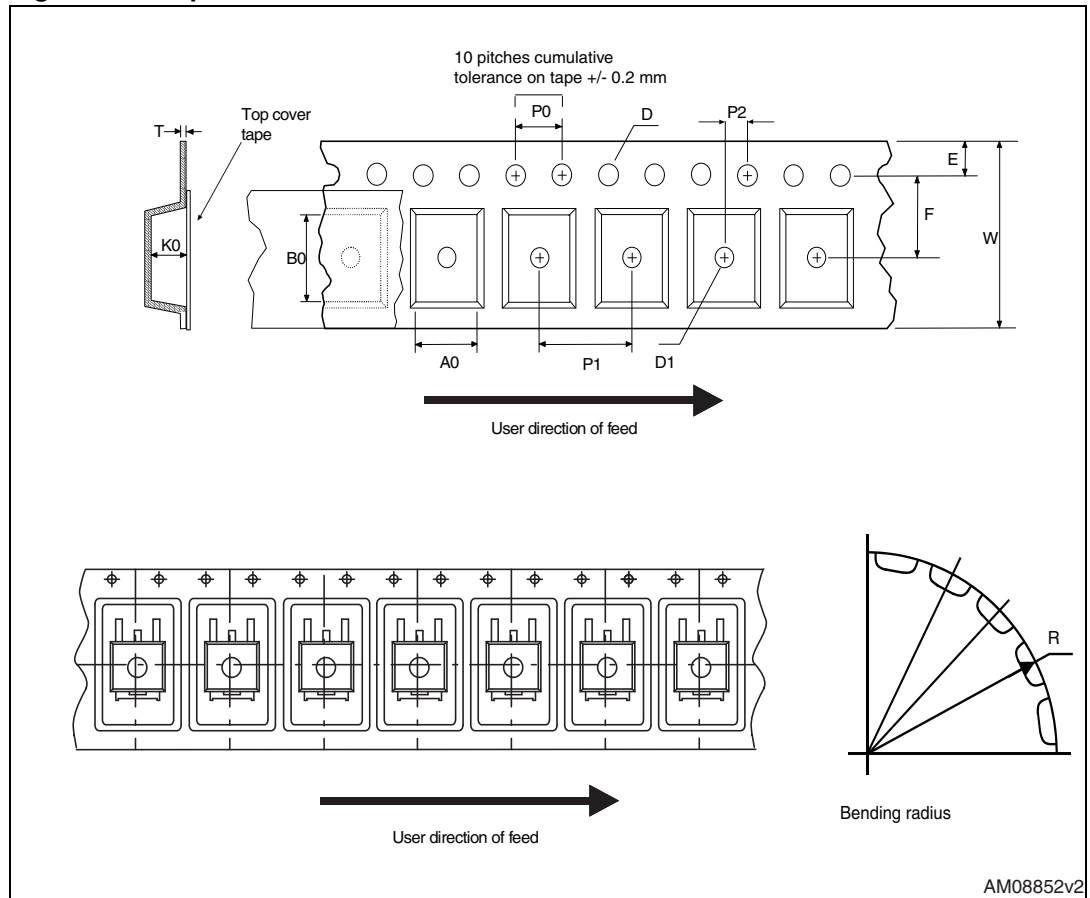
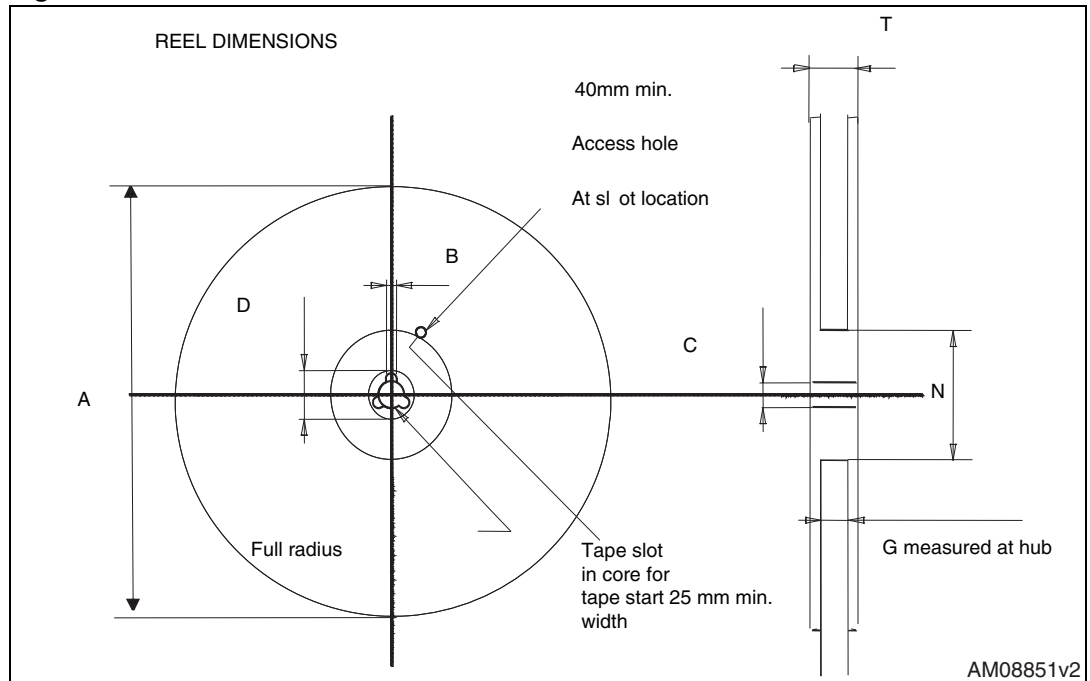

Figure 29. Reel



6 Revision history

Table 13. Document revision history

| Date | Revision | Changes |
|-------------|----------|--|
| 15-Nov-2007 | 1 | First release. |
| 22-Jan-2008 | 2 | Document status promoted from target specification to preliminary data. |
| 08-Apr-2008 | 3 | – Updated Table 3: Thermal data on page 3 ; – Document status promoted from preliminary data to datasheet. |
| 03-Mar-2009 | 4 | Q _g value has been updated. |
| 28-Nov-2011 | 5 | Updated Section 4: Package mechanical data and Section 5: Packing mechanical data . Minor text changes. |

Please Read Carefully:

Information in this document is provided solely in connection with ST products. STMicroelectronics NV and its subsidiaries ("ST") reserve the right to make changes, corrections, modifications or improvements, to this document, and the products and services described herein at any time, without notice.

All ST products are sold pursuant to ST's terms and conditions of sale.

Purchasers are solely responsible for the choice, selection and use of the ST products and services described herein, and ST assumes no liability whatsoever relating to the choice, selection or use of the ST products and services described herein.

No license, express or implied, by estoppel or otherwise, to any intellectual property rights is granted under this document. If any part of this document refers to any third party products or services it shall not be deemed a license grant by ST for the use of such third party products or services, or any intellectual property contained therein or considered as a warranty covering the use in any manner whatsoever of such third party products or services or any intellectual property contained therein.

UNLESS OTHERWISE SET FORTH IN ST'S TERMS AND CONDITIONS OF SALE ST DISCLAIMS ANY EXPRESS OR IMPLIED WARRANTY WITH RESPECT TO THE USE AND/OR SALE OF ST PRODUCTS INCLUDING WITHOUT LIMITATION IMPLIED WARRANTIES OF MERCHANTABILITY, FITNESS FOR A PARTICULAR PURPOSE (AND THEIR EQUIVALENTS UNDER THE LAWS OF ANY JURISDICTION), OR INFRINGEMENT OF ANY PATENT, COPYRIGHT OR OTHER INTELLECTUAL PROPERTY RIGHT.

UNLESS EXPRESSLY APPROVED IN WRITING BY TWO AUTHORIZED ST REPRESENTATIVES, ST PRODUCTS ARE NOT RECOMMENDED, AUTHORIZED OR WARRANTED FOR USE IN MILITARY, AIR CRAFT, SPACE, LIFE SAVING, OR LIFE SUSTAINING APPLICATIONS, NOR IN PRODUCTS OR SYSTEMS WHERE FAILURE OR MALFUNCTION MAY RESULT IN PERSONAL INJURY, DEATH, OR SEVERE PROPERTY OR ENVIRONMENTAL DAMAGE. ST PRODUCTS WHICH ARE NOT SPECIFIED AS "AUTOMOTIVE GRADE" MAY ONLY BE USED IN AUTOMOTIVE APPLICATIONS AT USER'S OWN RISK.

Resale of ST products with provisions different from the statements and/or technical features set forth in this document shall immediately void any warranty granted by ST for the ST product or service described herein and shall not create or extend in any manner whatsoever, any liability of ST.

ST and the ST logo are trademarks or registered trademarks of ST in various countries.

Information in this document supersedes and replaces all information previously supplied.

The ST logo is a registered trademark of STMicroelectronics. All other names are the property of their respective owners.

© 2011 STMicroelectronics - All rights reserved

STMicroelectronics group of companies

Australia - Belgium - Brazil - Canada - China - Czech Republic - Finland - France - Germany - Hong Kong - India - Israel - Italy - Japan - Malaysia - Malta - Morocco - Philippines - Singapore - Spain - Sweden - Switzerland - United Kingdom - United States of America

www.st.com



单击下面可查看定价，库存，交付和生命周期等信息

[>>STMicro\(意法半导体\)](#)