

- Diagnostic feedback through input pin
- ESD protection
- Direct access to the gate of the Power MOSFET (analog driving)
- Compatible with standard Power MOSFET

### Description

The VNB35NV04-E, VNP35NV04-E and VNV35NV04-E are monolithic devices designed in STMicroelectronics® VIPower® M0-3 Technology, intended for replacement of standard Power MOSFETs from DC up to 25 kHz applications.

Built-in thermal shutdown, linear current limitation and overvoltage clamp protect the chip in harsh environments. Fault feedback can be detected by monitoring the voltage at the input pin.

### Features

Type	$R_{DS(on)}$	$I_{lim}$	$V_{clamp}$
VNB35NV04-E VNP35NV04-E VNV35NV04-E	10 m $\Omega$ <sup>(1)</sup>	30 A	40 V

1. For PowerSO-10 only

- Linear current limitation
- Thermal shutdown
- Short circuit protection
- Integrated clamp
- Low current drawn from input pin

Table 1. Device summary

Package	Order codes	
	Tube	Tape and reel
D <sup>2</sup> PAK	VNB35NV04-E	VNB35NV04TR-E
TO-220	VNP35NV04-E	—
PowerSO-10	VNV35NV04-E	VNV35NV04TR-E

# Contents

- 1        Block diagram and pin connection ..... 5**
  
- 2        Electrical specification ..... 6**
  - 2.1    Absolute maximum ratings ..... 6
  - 2.2    Thermal data ..... 7
  - 2.3    Electrical characteristics ..... 7
  - 2.4    Protection features ..... 9
  - 2.5    Electrical characteristics curves ..... 13
  
- 3        Package information ..... 17**
  - 3.1    ECOPACK® ..... 17
  - 3.2    TO-220 mechanical data ..... 17
  - 3.3    PowerSO-10 mechanical data ..... 19
  - 3.4    D2PAK mechanical data ..... 21
  - 3.5    TO-220 packing information ..... 23
  - 3.6    PowerSO-10 packing information ..... 24
  - 3.7    D<sup>2</sup>PAK packing information ..... 25
  
- 4        Revision history ..... 26**



## List of tables

Table 1.	Device summary . . . . .	1
Table 2.	Absolute maximum ratings . . . . .	6
Table 3.	Thermal data . . . . .	7
Table 4.	Off . . . . .	7
Table 5.	On . . . . .	7
Table 6.	Dynamic . . . . .	8
Table 7.	Switching . . . . .	8
Table 8.	Source drain diode . . . . .	8
Table 9.	Protections (-40°C < T <sub>j</sub> < 150°C, unless otherwise specified) . . . . .	8
Table 10.	TO-220 mechanical data . . . . .	17
Table 11.	PowerSO-10 mechanical data . . . . .	19
Table 12.	D2PAK mechanical data . . . . .	21
Table 13.	Document revision history . . . . .	26

## List of figures

Figure 1.	Block diagram . . . . .	5
Figure 2.	Pin connection . . . . .	5
Figure 3.	Current and voltage conventions . . . . .	6
Figure 4.	Switching time test circuit for resistive load . . . . .	10
Figure 5.	Test circuit for diode recovery times . . . . .	10
Figure 6.	Unclamped inductive load test circuits . . . . .	11
Figure 7.	Unclamped inductive waveforms . . . . .	11
Figure 8.	Input charge test circuit. . . . .	12
Figure 9.	Thermal impedance for TO-220 . . . . .	12
Figure 10.	Source-drain diode forward characteristics . . . . .	13
Figure 11.	Static drain source on resistance . . . . .	13
Figure 12.	PowerSO-10 static drain-source on resistance vs. input voltage . . . . .	13
Figure 13.	D <sup>2</sup> PAK and TO-220 static drain-source on resistance vs. input voltage. . . . .	13
Figure 14.	PowerSO-10 static drain-source on resistance vs. $i_D$ . . . . .	13
Figure 15.	D <sup>2</sup> PAK and TO-220 static drain-source on resistance vs. $i_D$ . . . . .	13
Figure 16.	Transconductance . . . . .	14
Figure 17.	Transfer characteristics . . . . .	14
Figure 18.	Output characteristics . . . . .	14
Figure 19.	Normalized on resistance vs. temperature . . . . .	14
Figure 20.	Turn-on current slope, $V_{IN} = 5\text{ V}$ . . . . .	14
Figure 21.	Turn-on current slope, $V_{IN} = 3.5\text{ V}$ . . . . .	14
Figure 22.	Input voltage vs. input charge. . . . .	15
Figure 23.	Turn off drain source voltage slope, $V_{IN} = 5\text{ V}$ . . . . .	15
Figure 24.	Turn off drain-source voltage slope, $V_{IN} = 3.5\text{ V}$ . . . . .	15
Figure 25.	Switching time resistive load (part 1) . . . . .	15
Figure 26.	Switching time resistive load (part 2) . . . . .	15
Figure 27.	Normalized input threshold voltage vs. temperature . . . . .	15
Figure 28.	Current limit vs. junction temperature . . . . .	16
Figure 29.	Step response current limit . . . . .	16
Figure 30.	Derating curve . . . . .	16
Figure 31.	TO-220 package dimensions . . . . .	18
Figure 32.	PowerSO-10 package dimensions . . . . .	20
Figure 33.	D <sup>2</sup> PAK package dimensions . . . . .	22
Figure 34.	TO-220 tube shipment (no suffix) . . . . .	23
Figure 35.	PowerSO-10 suggested pad layout . . . . .	24
Figure 36.	Tube shipment (no suffix) . . . . .	24
Figure 37.	Tape and reel shipment (suffix "13TR") . . . . .	24
Figure 38.	D <sup>2</sup> PAK footprint . . . . .	25
Figure 39.	Tube shipment (no suffix) . . . . .	25
Figure 40.	Tape and reel shipment (suffix "13TR") . . . . .	25

# 1 Block diagram and pin connection

Figure 1. Block diagram

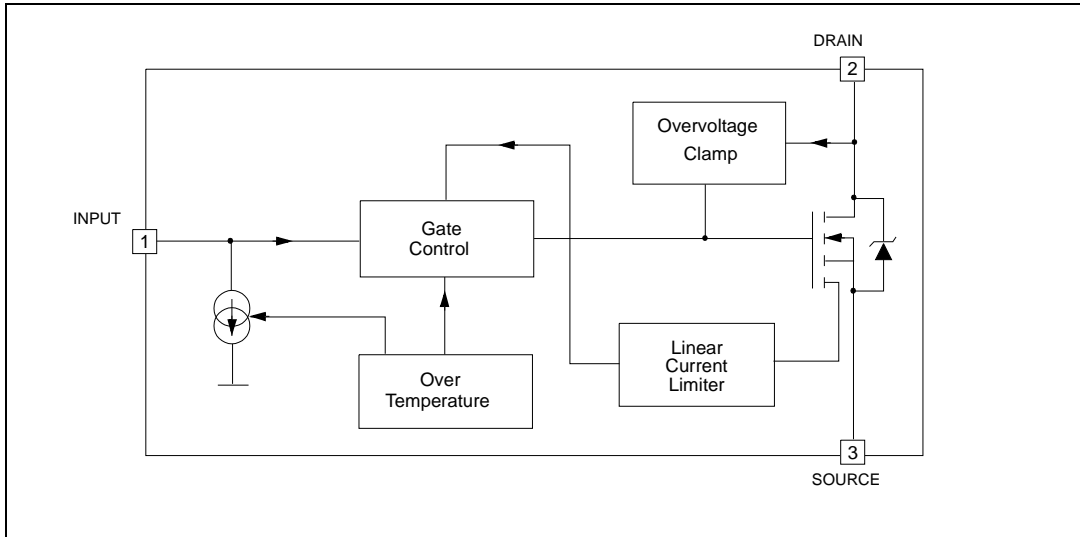
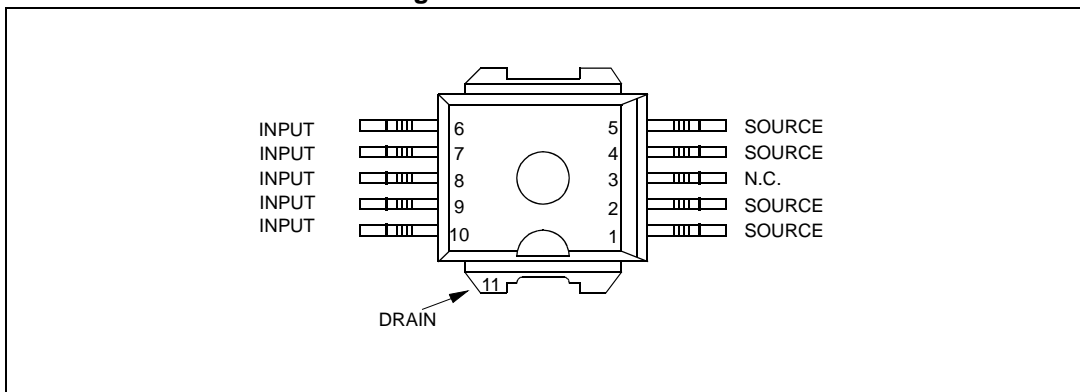


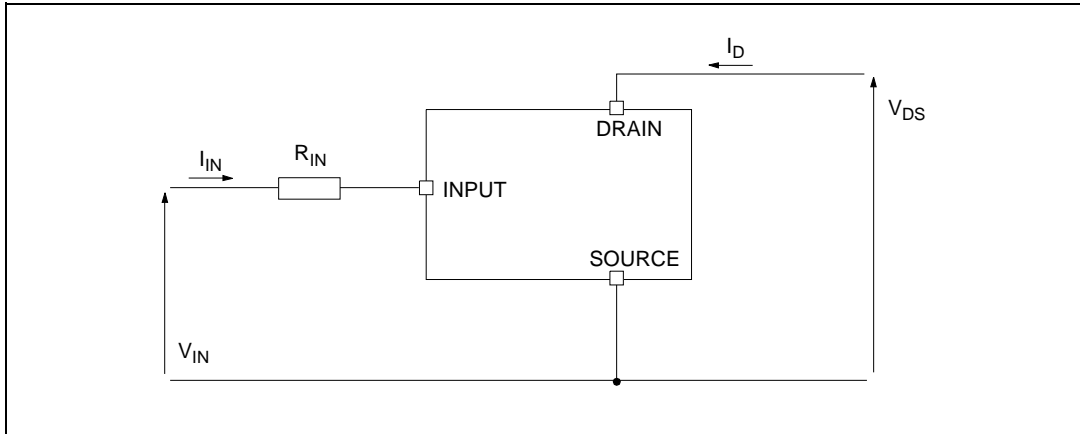
Figure 2. Pin connection



1. For the pins configuration related to TO-220, D<sup>2</sup>PAK, see [Figure 1](#).

## 2 Electrical specification

Figure 3. Current and voltage conventions



### 2.1 Absolute maximum ratings

Stressing the device above the rating listed in [Table 2](#) may cause permanent damage to the device. These are stress ratings only and operation of the device at these or any other conditions above those indicated in the operating sections of this specification is not implied. Exposure to the conditions in table below for extended periods may affect device reliability

Table 2. Absolute maximum ratings

Symbol	Parameter	Value			Unit
		PowerSO-10	D <sup>2</sup> PAK	TO-220	
$V_{DS}$	Drain-source voltage ( $V_{IN} = 0\text{ V}$ )	Internally clamped			V
$V_{IN}$	Input voltage	Internally clamped			V
$I_{IN}$	Input current	+/-20			mA
$R_{IN\text{ MIN}}$	Minimum input series impedance	4.7			$\Omega$
$I_D$	Drain current	Internally limited			A
$I_R$	Reverse DC output current	-30			A
$V_{ESD1}$	Electrostatic discharge ( $R = 1.5\text{ K}\Omega$ , $C = 100\text{ pF}$ )	4000			V
$V_{ESD2}$	Electrostatic discharge on output pin only ( $R = 330\ \Omega$ , $C = 150\text{ pF}$ )	16500			V
$P_{tot}$	Total dissipation at $T_c = 25^\circ\text{C}$	125	125	125	W
$T_j$	Operating junction temperature	Internally limited			$^\circ\text{C}$
$T_c$	Case operating temperature	Internally limited			$^\circ\text{C}$
$T_{stg}$	Storage temperature	-55 to 150			$^\circ\text{C}$

## 2.2 Thermal data

Table 3. Thermal data

Symbol	Parameter	Value			Unit
		PowerSO-10	D <sup>2</sup> PAK	TO-220	
R <sub>thj-case</sub>	Thermal resistance junction-case (max)	1	1	1	°C/W
R <sub>thj-amb</sub>	Thermal resistance junction-ambient (max)	50 <sup>(1)</sup>	50 <sup>(1)</sup>	50	°C/W

1. When mounted on a standard single-sided FR4 board with 50mm<sup>2</sup> of Cu (at least 35 mm thick) connected to all DRAIN pins.

## 2.3 Electrical characteristics

-40°C < T<sub>j</sub> < 150°C, unless otherwise specified.

Table 4. Off

Symbol	Parameter	Test conditions	Min	Typ	Max	Unit
V <sub>CLAMP</sub>	Drain-source clamp voltage	V <sub>IN</sub> = 0 V; I <sub>D</sub> = 15 A	40	45	55	V
V <sub>CLTH</sub>	Drain-source clamp threshold voltage	V <sub>IN</sub> = 0 V; I <sub>D</sub> = 2 mA	36			V
V <sub>INTH</sub>	Input threshold voltage	V <sub>DS</sub> = V <sub>IN</sub> ; I <sub>D</sub> = 1 mA	0.5		2.5	V
I <sub>ISS</sub>	Supply current from input pin	V <sub>DS</sub> = 0 V; V <sub>IN</sub> = 5 V		100	150	μA
V <sub>INCL</sub>	Input-source clamp voltage	I <sub>IN</sub> = 1 mA	6	6.8	8	V
		I <sub>IN</sub> = -1 mA	-1.0		-0.3	V
I <sub>DSS</sub>	Zero input voltage drain current (V <sub>IN</sub> = 0 V)	V <sub>DS</sub> = 13 V; V <sub>IN</sub> = 0 V; T <sub>j</sub> = 25 °C			30	μA
		V <sub>DS</sub> = 25 V; V <sub>IN</sub> = 0 V			75	μA

Table 5. On

Symbol	Parameter	Test conditions	Max		Unit
			PowerSO-10	D <sup>2</sup> PAK TO-220	
R <sub>DS(on)</sub>	Static drain-source on resistance	V <sub>IN</sub> = 5 V; I <sub>D</sub> = 15 A; T <sub>j</sub> = 25 °C	10	13	mΩ
		V <sub>IN</sub> = 5 V; I <sub>D</sub> = 15 A; T <sub>j</sub> = 150 °C	20	24	mΩ

$T_j = 25^\circ\text{C}$ , unless otherwise specified.

Table 6. Dynamic

Symbol	Parameter	Test conditions	Min	Typ	Max	Unit
$g_{fs}^{(1)}$	Forward transconductance	$V_{DD} = 13\text{ V}; I_D = 15\text{ A}$	—	35	—	S
$C_{OSS}$	Output capacitance	$V_{DS} = 13\text{ V}; f = 1\text{ MHz}; V_{IN} = 0\text{ V}$	—	1300	—	pF

1. Pulsed: Pulse duration = 300 ms, duty cycle 1.5%

Table 7. Switching

Symbol	Parameter	Test conditions	Min	Typ	Max	Unit
$t_{d(on)}$	Turn-on delay time	$V_{DD} = 15\text{ V}; I_D = 15\text{ A};$ $V_{gen} = 5\text{ V};$ $R_{gen} = R_{IN\text{ MIN}} = 4.7\ \Omega$ (see Figure 3)	—	150	500	ns
$t_r$	Rise time		—	840	2500	ns
$t_{d(off)}$	Turn-off delay time		—	980	3000	ns
$t_f$	Fall time		—	600	1500	ns
$t_{d(on)}$	Turn-on delay time	$V_{DD} = 15\text{ V}; I_D = 15\text{ A};$ $V_{gen} = 5\text{ V}; R_{gen} = 2.2\text{ K}\Omega$ (see Figure 3)	—	4	12	$\mu\text{s}$
$t_r$	Rise time		—	27	100	$\mu\text{s}$
$t_{d(off)}$	Turn-off delay time		—	34	120	$\mu\text{s}$
$t_f$	Fall time		—	31	110	$\mu\text{s}$
$(di/dt)_{on}$	Turn-on current slope	$V_{DD} = 15\text{ V}; I_D = 15\text{ A}; V_{gen} = 5\text{ V};$ $R_{gen} = R_{IN\text{ MIN}} = 4.7\ \Omega$	—	18		$\text{A}/\mu\text{s}$
$Q_i$	Total input charge	$V_{DD} = 12\text{ V}; I_D = 15\text{ A}; V_{IN} = 5\text{ V};$ $I_{gen} = 2.13\text{ mA}$ (see Figure 8)	—	118		nC

Table 8. Source drain diode

Symbol	Parameter	Test Conditions	Min	Typ	Max	Unit
$V_{SD}^{(1)}$	Forward on voltage	$I_{SD} = 15\text{ A}; V_{IN} = 0\text{ V}$	—	0.8	—	V
$t_{rr}$	Reverse recovery time	$I_{SD} = 15\text{ A}; di/dt = 100\text{ A}/\mu\text{s};$ $V_{DD} = 30\text{ V}; L = 200\ \mu\text{H}$ (see Figure 4)	—	400	—	ns
$Q_{rr}$	Reverse recovery charge		—	1.4	—	$\mu\text{C}$
$I_{RRM}$	Reverse recovery current		—	7	—	A

1. Pulsed: Pulse duration = 300 ms, duty cycle 1.5%

Table 9. Protections ( $-40^\circ\text{C} < T_j < 150^\circ\text{C}$ , unless otherwise specified)

Symbol	Parameter	Test Conditions	Min	Typ	Max	Unit
$I_{lim}$	Drain current limit	$V_{IN} = 6\text{ V}; V_{DS} = 13\text{ V}$	30	45	60	A
$t_{dlim}$	Step response current limit	$V_{IN} = 6\text{ V}; V_{DS} = 13\text{ V}$		50		$\mu\text{s}$



Table 9. Protections ( $-40^{\circ}\text{C} < T_j < 150^{\circ}\text{C}$ , unless otherwise specified) (continued)

Symbol	Parameter	Test Conditions	Min	Typ	Max	Unit
$T_{jsh}$	Overtemperature shutdown		150	175	200	$^{\circ}\text{C}$
$T_{jrs}$	Overtemperature reset		135			$^{\circ}\text{C}$
$I_{gf}$	Fault Sink Current	$V_{IN} = 5\text{ V}; V_{DS} = 13\text{ V}; T_j = T_{jsh}$	10	15	20	mA
$E_{as}$	Single pulse avalanche energy	Starting $T_j = 25^{\circ}\text{C}; V_{DD} = 24\text{ V}; V_{IN} = 5\text{ V}; R_{gen} = R_{IN\text{ MIN}} = 4.7\ \Omega; L = 24\text{ mH}$ (see <a href="#">Figure 6</a> and <a href="#">Figure 7</a> )	1.7			J

## 2.4 Protection features

During normal operation, the INPUT pin is electrically connected to the gate of the internal power MOSFET through a low impedance path.

The device then behaves like a standard power MOSFET and can be used as a switch from DC up to 25 KHz. The only difference from the user's standpoint is that a small DC current  $I_{ISS}$  (typ. 100  $\mu\text{A}$ ) flows into the INPUT pin in order to supply the internal circuitry.

The device integrates:

- **Overtoltage clamp protection:**  
internally set at 45 V, along with the rugged avalanche characteristics of the Power MOSFET stage give this device unrivalled ruggedness and energy handling capability. This feature is mainly important when driving inductive loads.
- **Linear current limiter circuit:**  
limits the drain current  $I_D$  to  $I_{lim}$  whatever the INPUT pin voltages is. When the current limiter is active, the device operates in the linear region, so power dissipation may exceed the capability of the heatsink. Both case and junction temperatures increase, and if this phase lasts long enough, junction temperature may reach the overtemperature threshold  $T_{jsh}$ .
- **Overtemperature and short circuit protection:**  
these are based on sensing the chip temperature and are not dependent on the input voltage. The location of the sensing element on the chip in the power stage area ensures fast, accurate detection of the junction temperature. Overtemperature cutout occurs in the range  $150^{\circ}\text{C}$  to  $190^{\circ}\text{C}$ , a typical value being  $170^{\circ}\text{C}$ . The device is automatically restarted when the chip temperature falls of about  $15^{\circ}\text{C}$  below shutdown temperature.
- **Status feedback:**  
in the case of an overtemperature fault condition ( $T_j > T_{jsh}$ ), the device tries to sink a diagnostic current  $I_{gf}$  through the INPUT pin in order to indicate fault condition. If driven from a low impedance source, this current may be used in order to warn the control circuit of a device shutdown. If the drive impedance is high enough so that the INPUT pin driver is not able to supply the current  $I_{gf}$ , the INPUT pin falls to 0 V. This does not however affect the device operation: no requirement is put on the current capability of the INPUT pin driver except to be able to supply the normal operation drive current  $I_{ISS}$ .

Additional features of this device are ESD protection according to the Human Body model and the ability to be driven from a TTL Logic circuit.

Figure 4. Switching time test circuit for resistive load

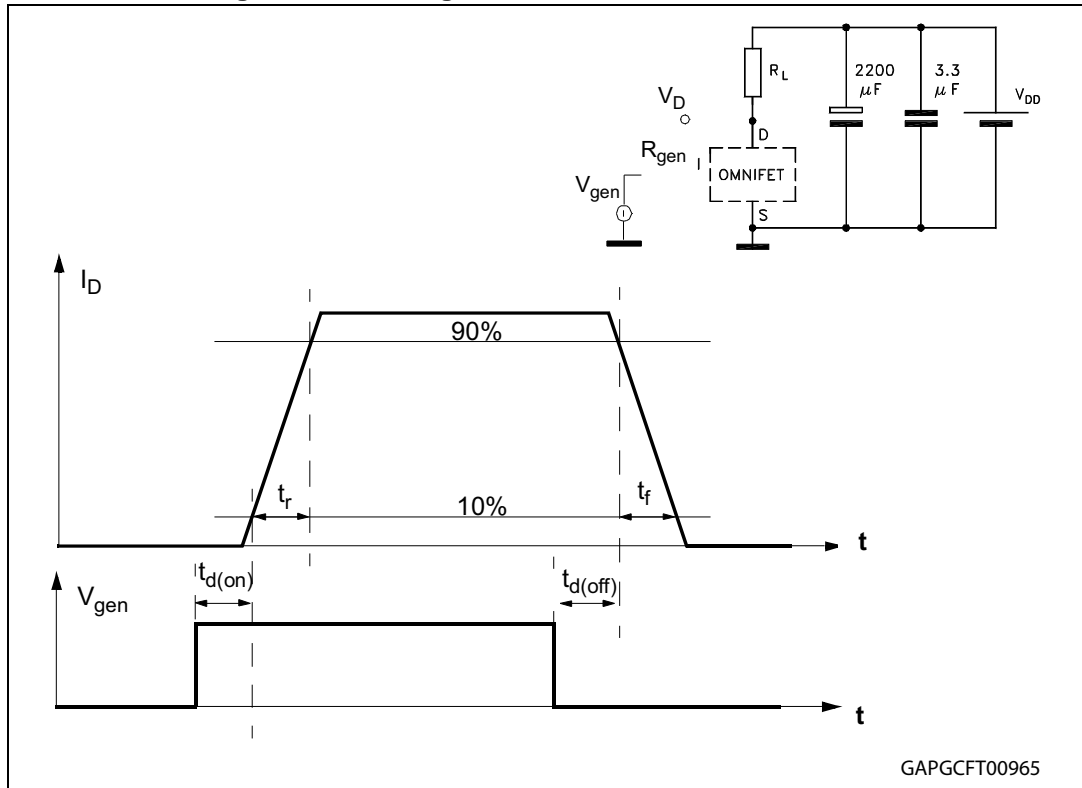


Figure 5. Test circuit for diode recovery times

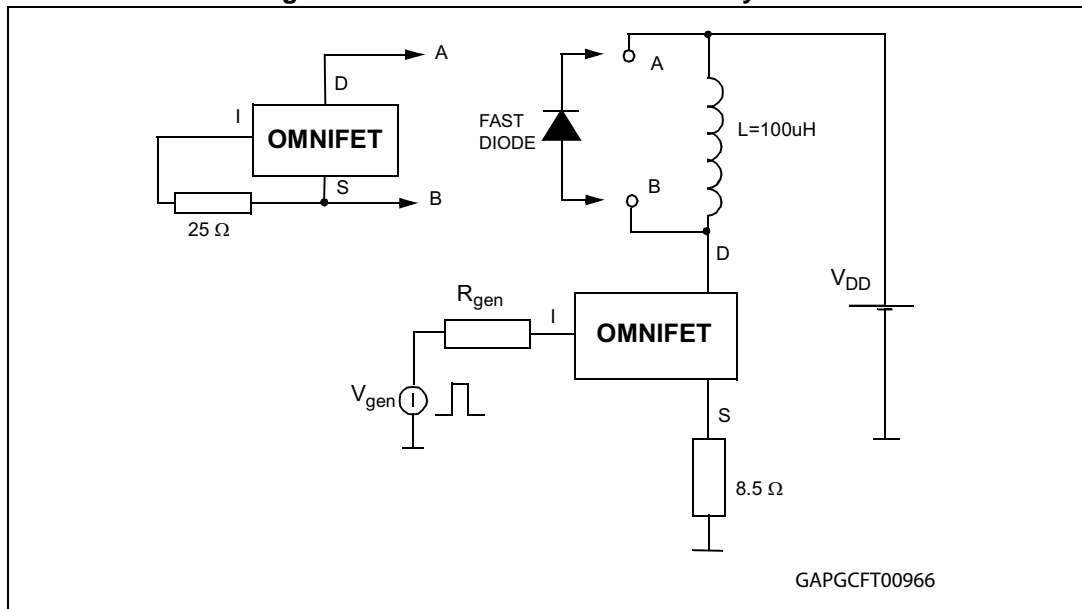


Figure 6. Unclamped inductive load test circuits

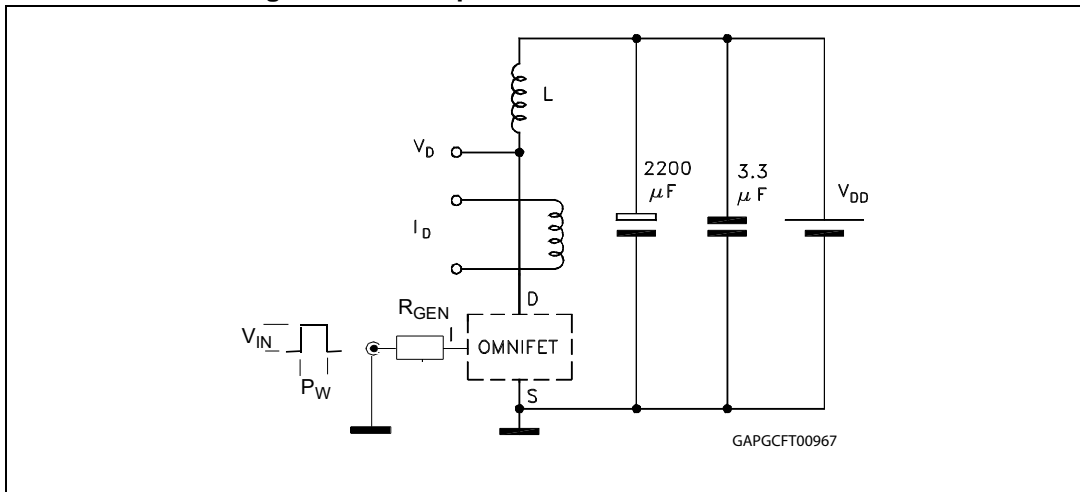


Figure 7. Unclamped inductive waveforms

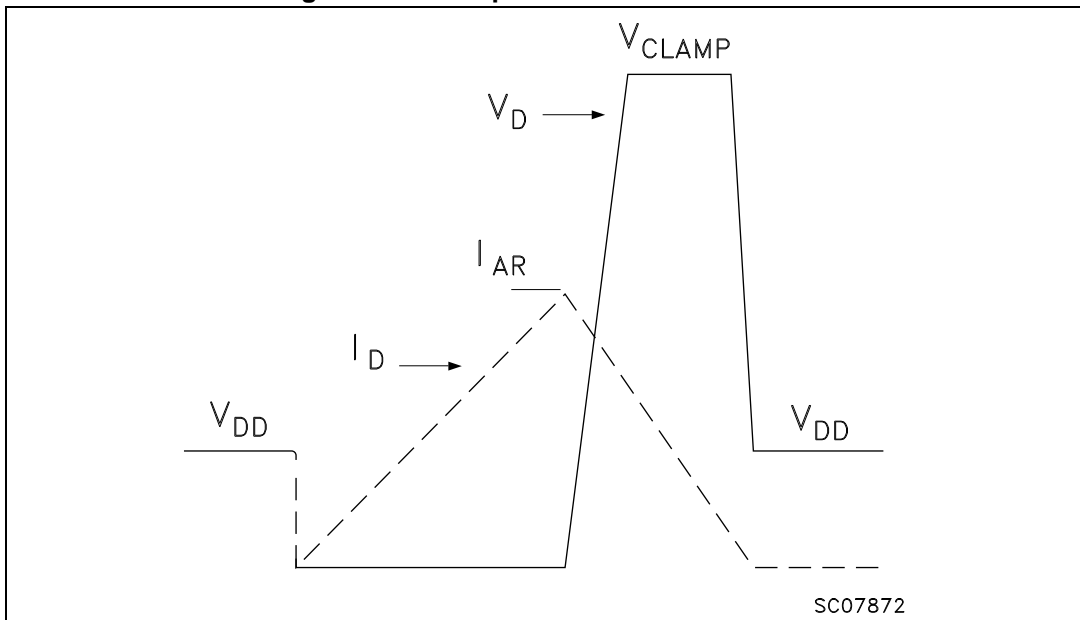


Figure 8. Input charge test circuit

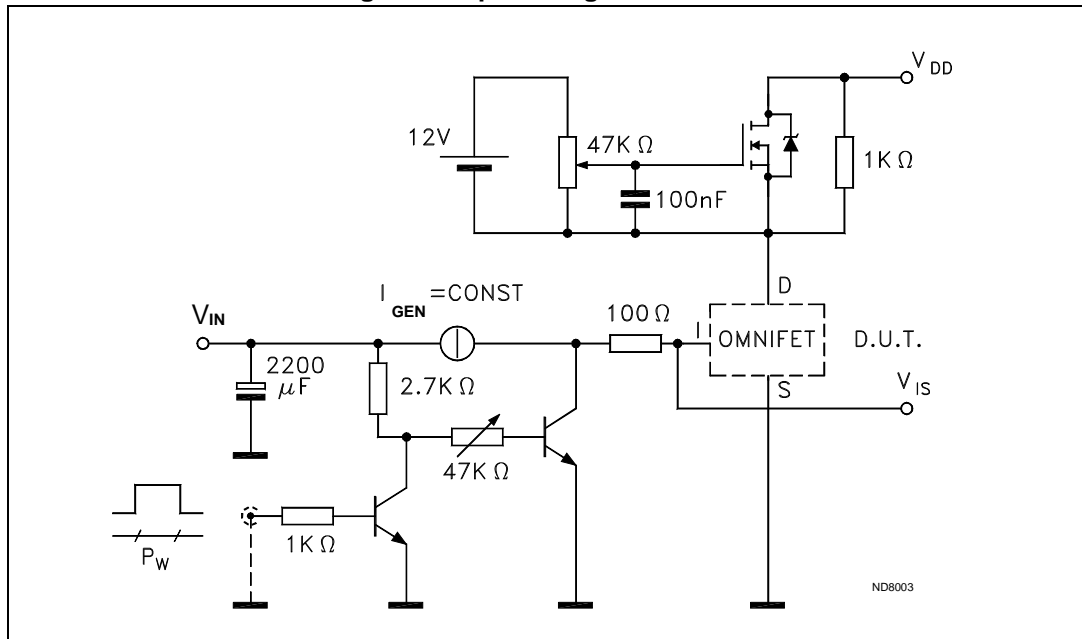
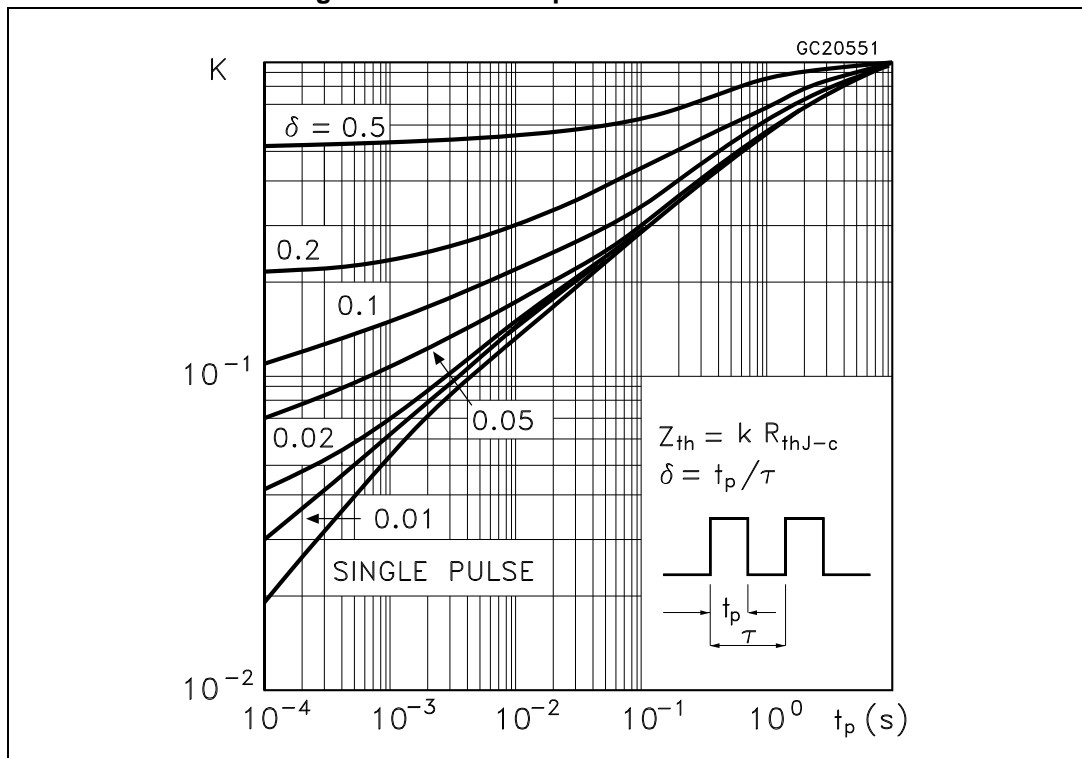
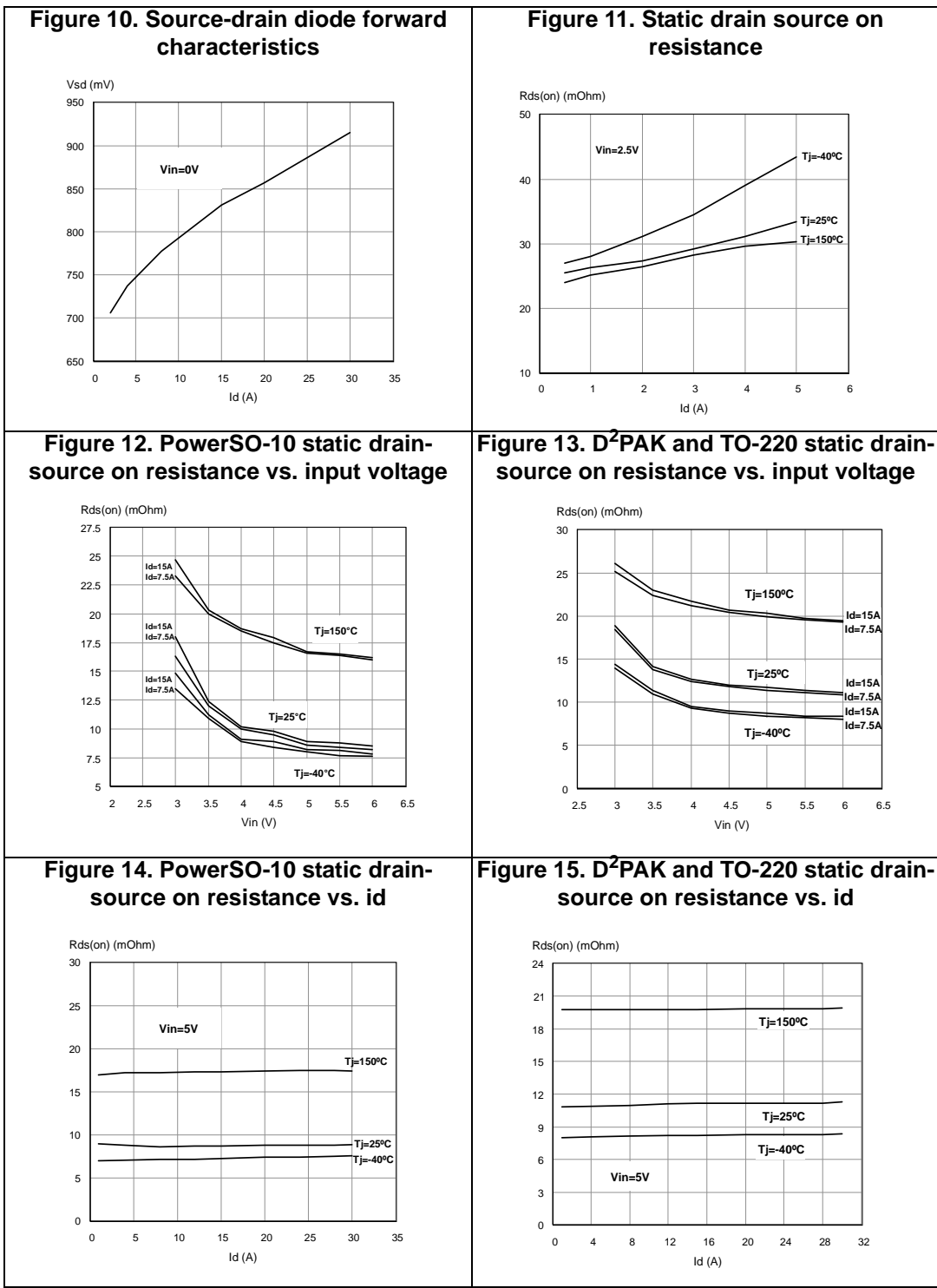


Figure 9. Thermal impedance for TO-220



## 2.5 Electrical characteristics curves



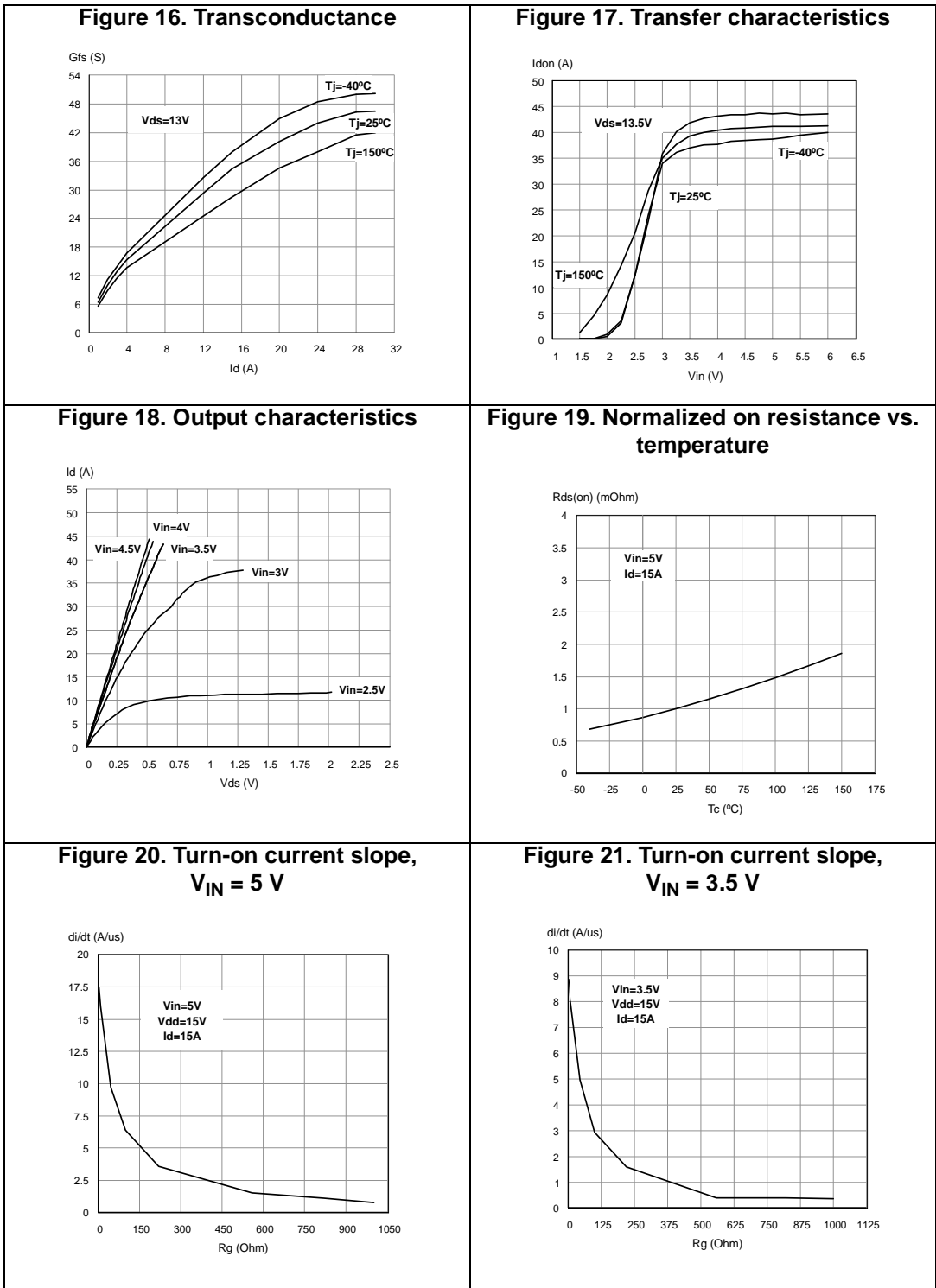


Figure 22. Input voltage vs. input charge

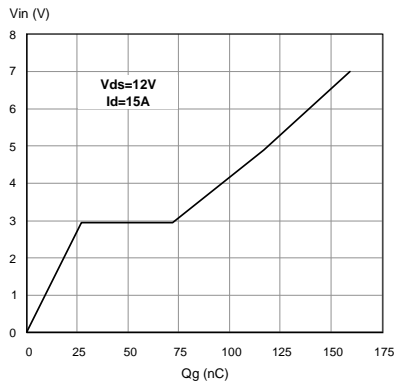


Figure 23. Turn off drain source voltage slope, VIN = 5 V

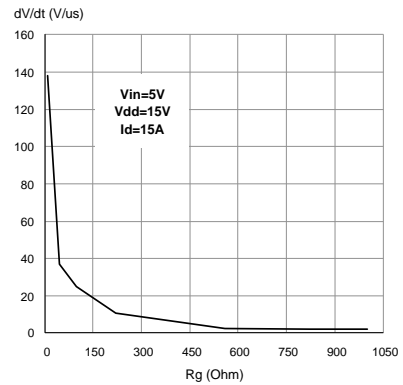


Figure 24. Turn off drain-source voltage slope, VIN = 3.5 V

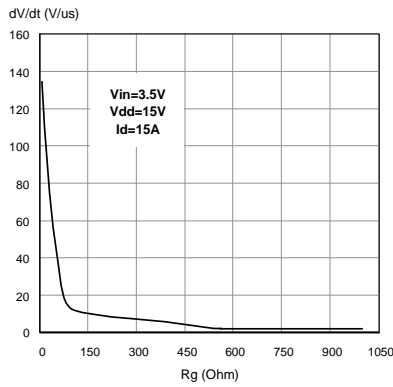


Figure 25. Switching time resistive load (part 1)

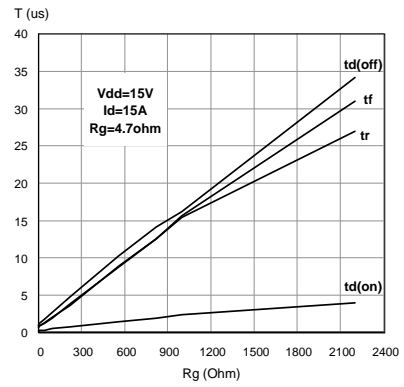


Figure 26. Switching time resistive load (part 2)

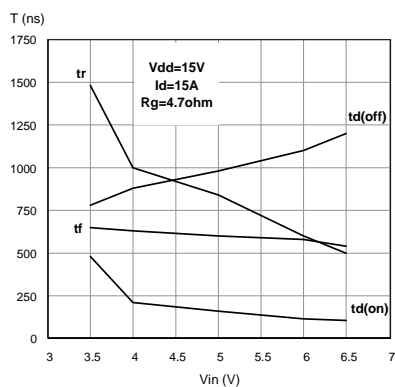
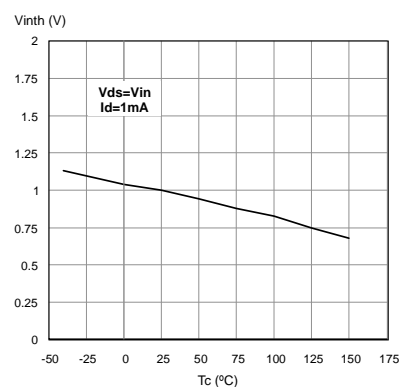
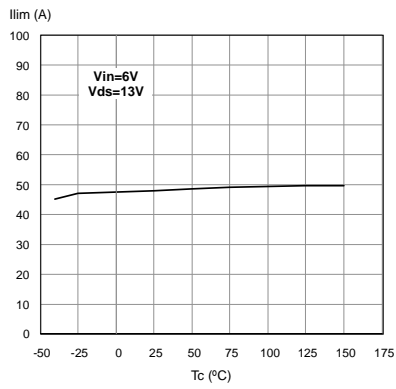


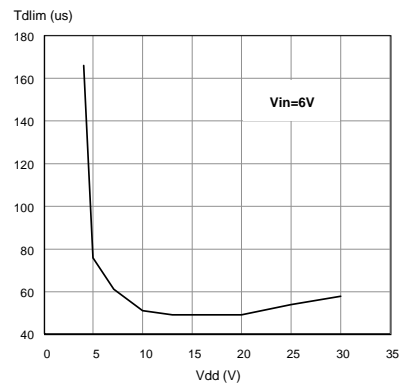
Figure 27. Normalized input threshold voltage vs. temperature



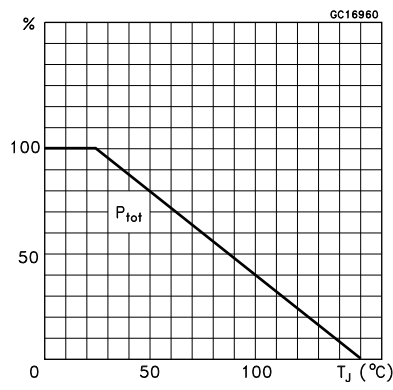
**Figure 28. Current limit vs. junction temperature**



**Figure 29. Step response current limit**



**Figure 30. Derating curve**





### 3 Package information

#### 3.1 ECOPACK®

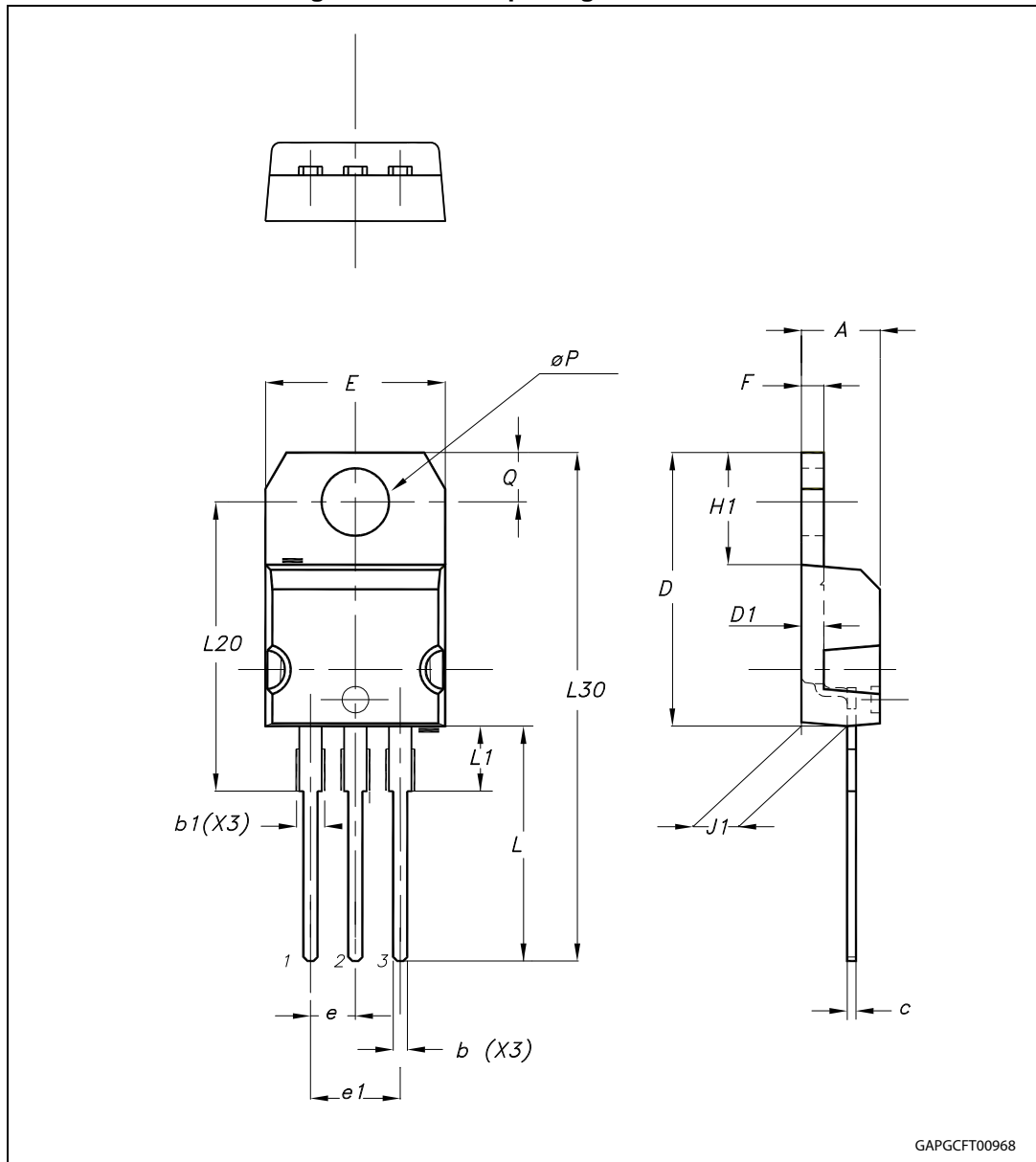
In order to meet environmental requirements, ST offers these devices in different grades of ECOPACK® packages, depending on their level of environmental compliance. ECOPACK® specifications, grade definitions and product status are available at: [www.st.com](http://www.st.com). ECOPACK® is an ST trademark.

#### 3.2 TO-220 mechanical data

Table 10. TO-220 mechanical data

Dim.	mm.		
	Min.	Typ	Max.
A	4.40		4.60
b	0.61		0.88
b1	1.14		1.70
c	0.48		0.70
D	15.25		15.75
D1		1.27	
E	10		10.40
e	2.40		2.70
e1	4.95		5.15
F	1.23		1.32
H1	6.20		6.60
J1	2.40		2.72
L	13		14
L1	3.50		3.93
L20		16.40	
L30		28.90	
∅P	3.75		3.85
Q	2.65		2.95
Package weight	1.9Gr. (Typ.)		

Figure 31. TO-220 package dimensions



GAPGCT00968

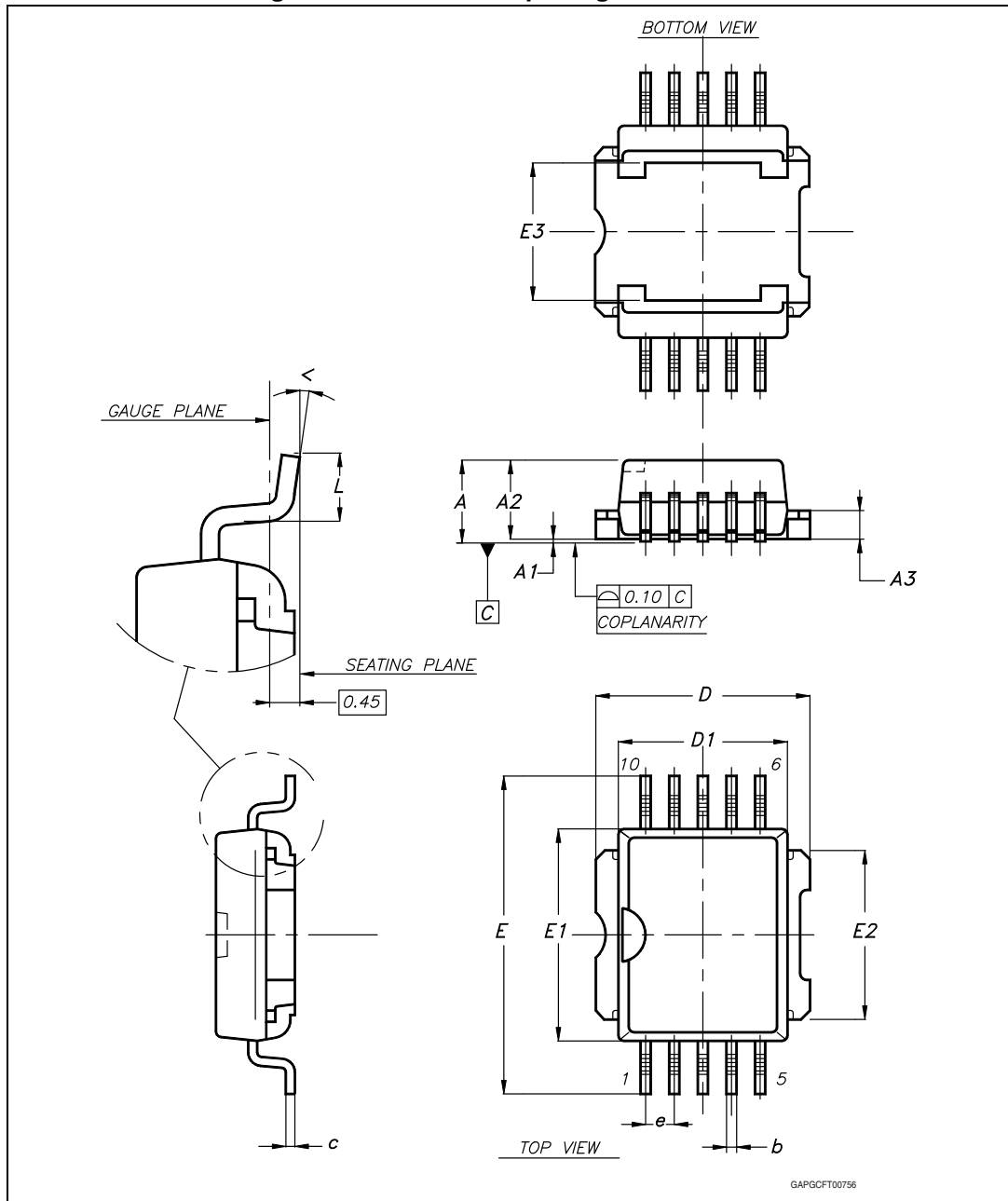
### 3.3 PowerSO-10 mechanical data

Table 11. PowerSO-10 mechanical data

Dim.	mm.		
	Min.	Typ.	Max.
A			3.70
A1	0.00		0.10
A2	3.40		3.60
A3	1.25		1.35
b	0.40		0.53
c	0.35		0.55
D	9.40		9.60
D1 <sup>(1)</sup>	7.40		7.60
E	13.80		14.40
E1 <sup>(1)</sup>	9.30		9.50
E2	7.20		7.60
E3	5.90		6.10
e		1.27	
L	0.95		1.65
<	0°		8°

1. Resin protrusion not included (max value: 0.20 mm per side)

Figure 32. PowerSO-10 package dimensions

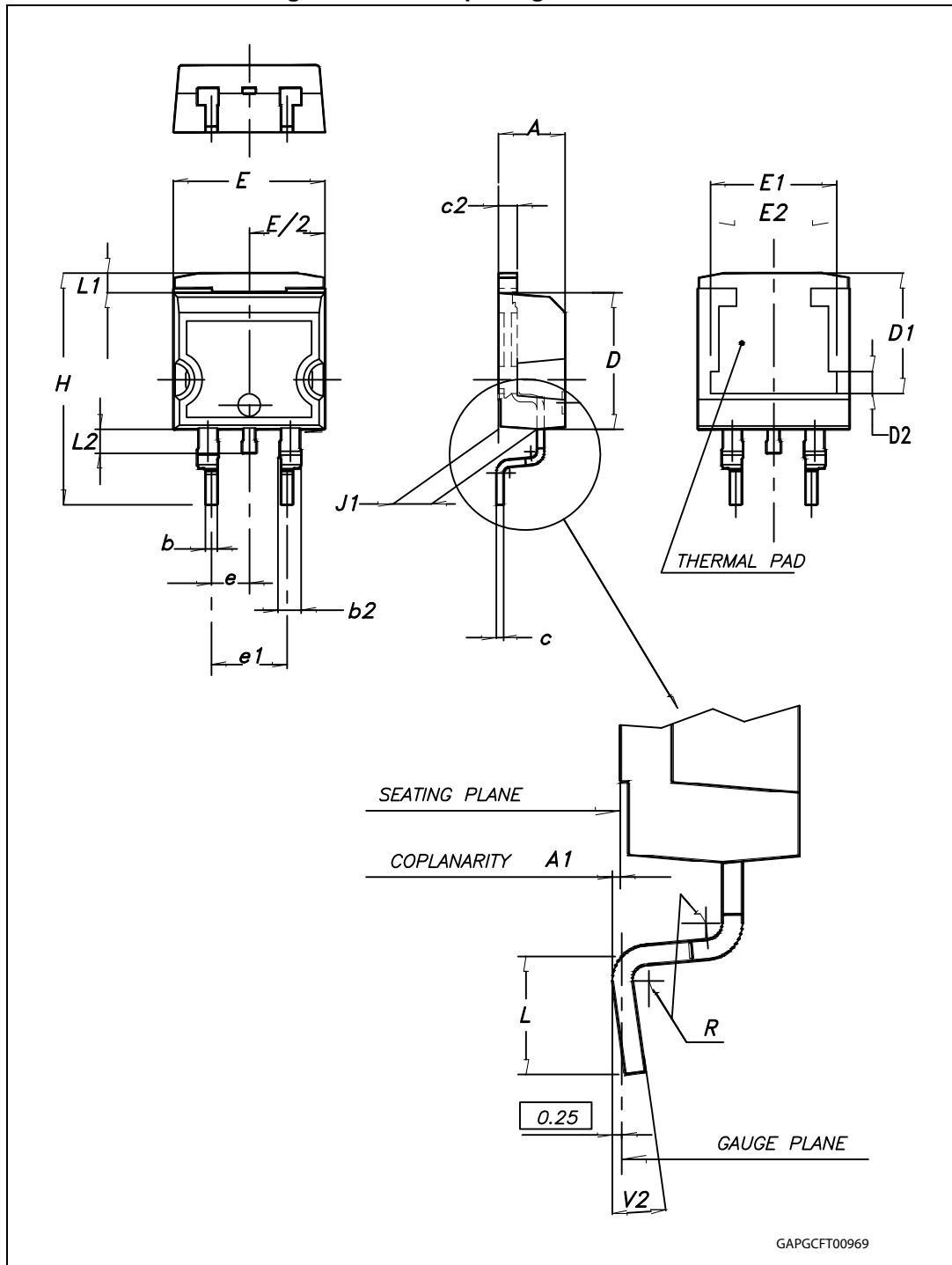


### 3.4 D<sup>2</sup>PAK mechanical data

Table 12. D<sup>2</sup>PAK mechanical data

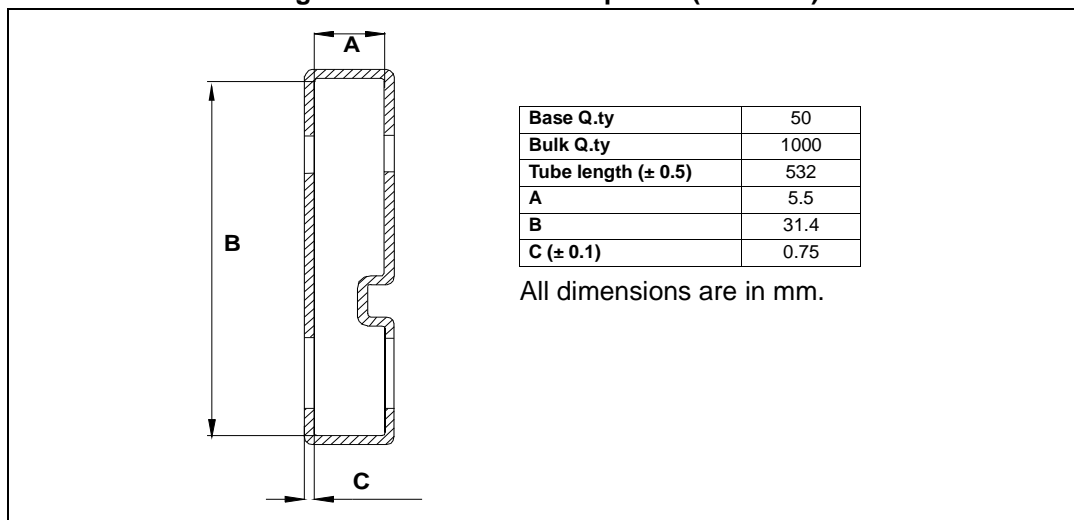
Dim.	mm.		
	Min.	Typ	Max.
A	4.40		4.60
A1	0.03		0.23
b	0.70		0.93
b2	1.14		1.70
c	0.45		0.60
c2	1.23		1.36
D	8.95		9.35
D1	7.50	7.75	8.00
D2	1.10	1.30	1.50
E	10		10.40
E1	8.50	8.70	8.90
E2	6.85	7.05	7.25
e		2.54	
e1	4.88		5.28
H	15		15.85
J1	2.49		2.69
L	2.29		2.79
L1	1.27		1.40
L2	1.30		1.75
R		0.4	
V2	0°		8°

Figure 33. D<sup>2</sup>PAK package dimensions

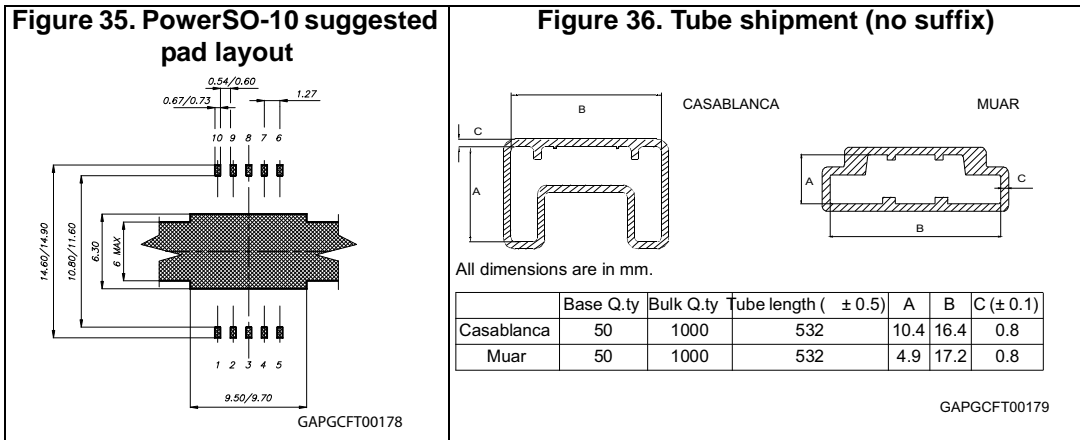


### 3.5 TO-220 packing information

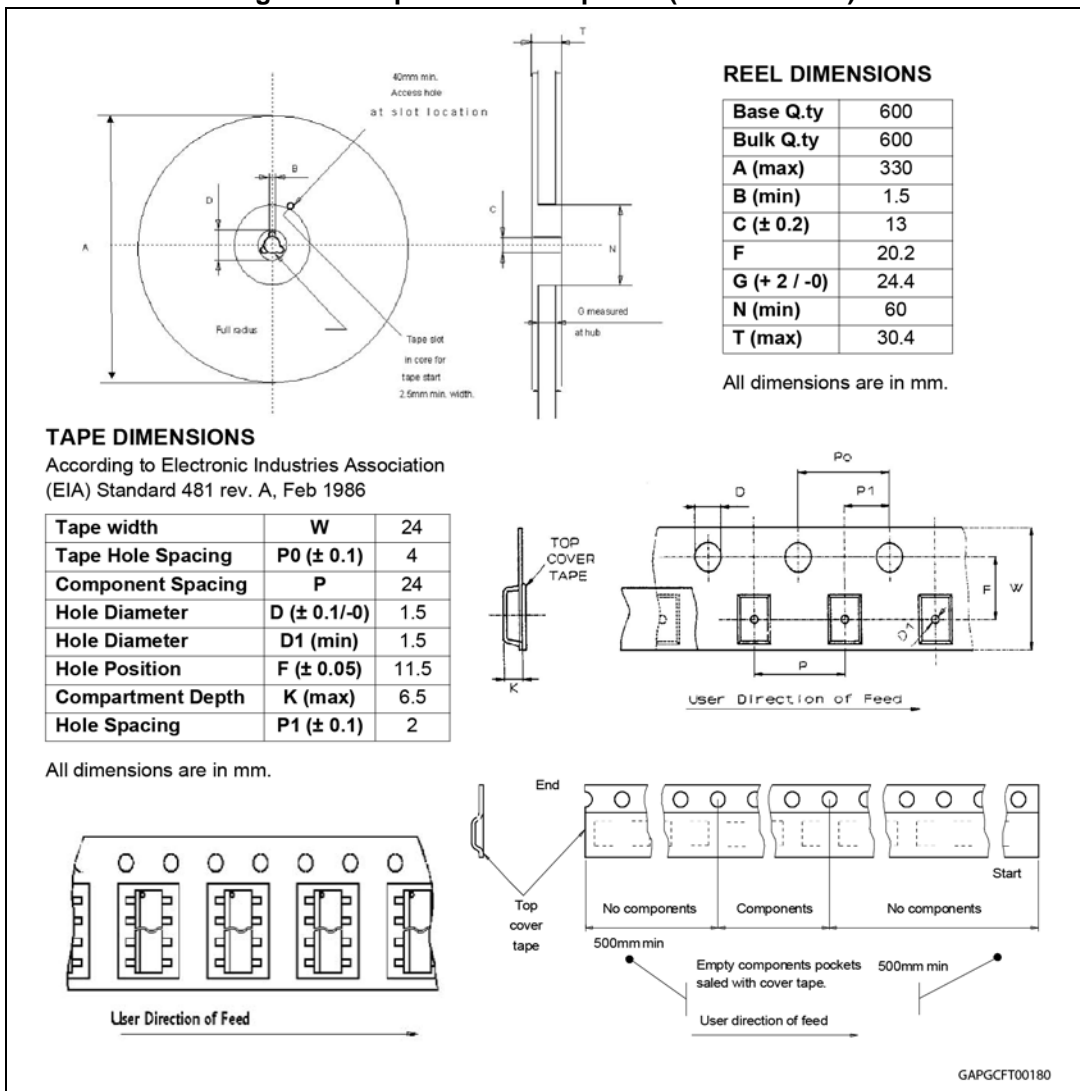
Figure 34. TO-220 tube shipment (no suffix)



### 3.6 PowerSO-10 packing information

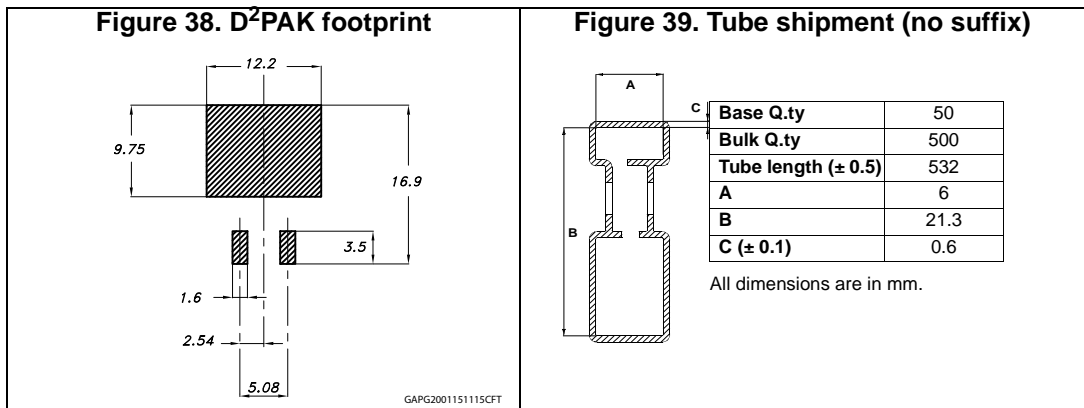


**Figure 37. Tape and reel shipment (suffix "13TR")**

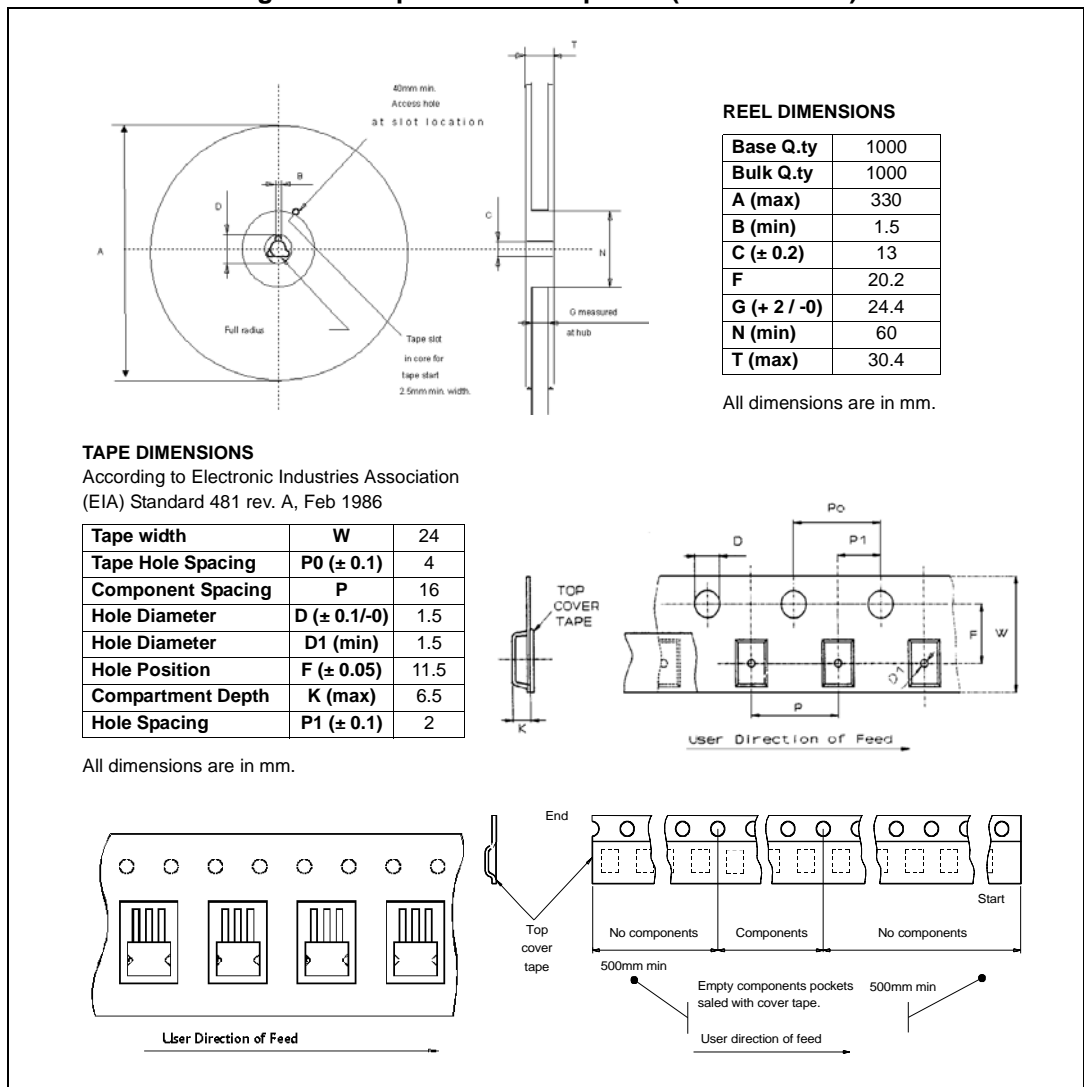




### 3.7 D<sup>2</sup>PAK packing information



**Figure 40. Tape and reel shipment (suffix "13TR")**



## 4 Revision history

Table 13. Document revision history

Date	Revision	Changes
19-Sep-2012	1	Initial release.
25-Sep-2013	2	Updated disclaimer.
30-Sep-2013	3	Added <a href="#">Table 5: On</a>
09-Oct-2013	4	Corrections of typos
03-Feb-2015	5	Updated <a href="#">Section 3.2: TO-220 mechanical data</a> and <a href="#">Section 3.4: D2PAK mechanical data</a> Updated <a href="#">Figure 38: D<sup>2</sup>PAK footprint</a>

**IMPORTANT NOTICE – PLEASE READ CAREFULLY**

STMicroelectronics NV and its subsidiaries ("ST") reserve the right to make changes, corrections, enhancements, modifications, and improvements to ST products and/or to this document at any time without notice. Purchasers should obtain the latest relevant information on ST products before placing orders. ST products are sold pursuant to ST's terms and conditions of sale in place at the time of order acknowledgement.

Purchasers are solely responsible for the choice, selection, and use of ST products and ST assumes no liability for application assistance or the design of Purchasers' products.

No license, express or implied, to any intellectual property right is granted by ST herein.

Resale of ST products with provisions different from the information set forth herein shall void any warranty granted by ST for such product.

ST and the ST logo are trademarks of ST. All other product or service names are the property of their respective owners.

Information in this document supersedes and replaces information previously supplied in any prior versions of this document.

© 2015 STMicroelectronics – All rights reserved



单击下面可查看定价，库存，交付和生命周期等信息

[>>STMicro\(意法半导体\)](#)