

N-channel 100 V, 0.0034 Ω typ., 110 A, STripFET™ F7 Power MOSFET in a H²PAK-2 package

Datasheet preliminary data

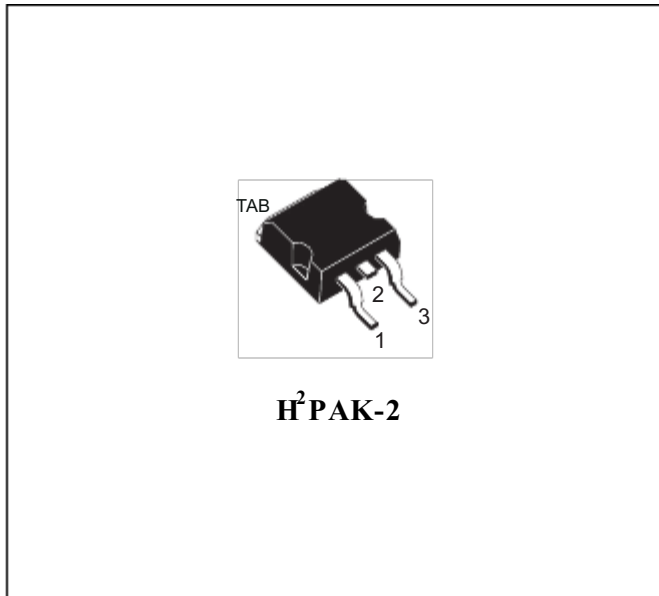
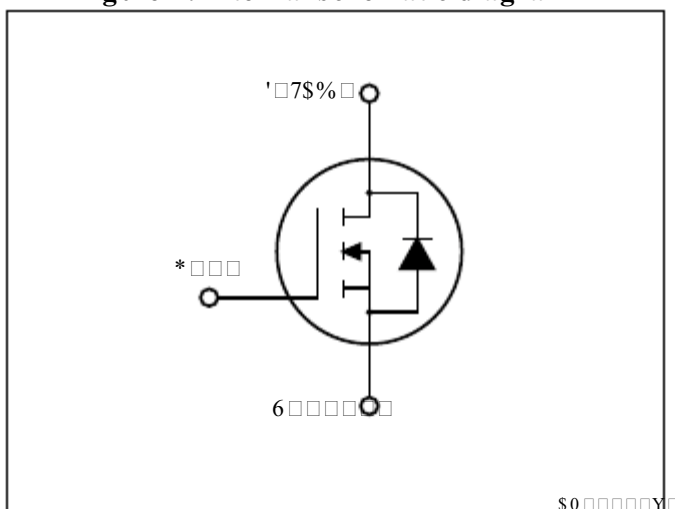

Figure 1. Internal schematic diagram



Features

| Order code | V _{DS} | R _{DS(on)max} | I _D | P _{TOT} |
|------------|-----------------|------------------------|----------------|------------------|
| STH15810-2 | 100 V | 0.0039 Ω | 110 A | 250 W |

- 100% avalanche tested
- Ultra low on-resistance

Applications

- Switching applications

Description

This N-channel Power MOSFETs utilize STripFET™ F7 technology with an enhanced trench gate structure that results in very low on-state resistance, while also reducing internal capacitance and gate charge for faster and more efficient switching.

Table 1. Device summary

| Order code | Marking | Package | Packaging |
|------------|---------|----------------------|---------------|
| STH15810-2 | 15810 | H ² PAK-2 | Tape and reel |

Contents

| | | |
|----------|---|-----------|
| 1 | Electrical ratings | 3 |
| 2 | Electrical characteristics | 4 |
| | 2.1 Electrical characteristics (curves) | 6 |
| 3 | Test circuits | 8 |
| 4 | Package mechanical data | 9 |
| 5 | Packaging mechanical data | 13 |
| 6 | Revision history | 15 |



1 Electrical ratings

Table 2. Absolute maximum ratings

| Symbol | Parameter | Value | Unit |
|----------------|---|------------|------------------|
| V_{DS} | Drain-source voltage | 100 | V |
| V_{GS} | Gate- source voltage | ± 20 | V |
| I_D | Drain current (continuous) at $T_F = 25\text{ }^\circ\text{C}$ | 110 | A |
| I_D | Drain current (continuous) at $T_F = 100\text{ }^\circ\text{C}$ | 110 | A |
| $I_{DM}^{(1)}$ | Drain current (pulsed) $T_F = 25\text{ }^\circ\text{C}$ | 440 | A |
| P_{TOT} | Total dissipation at $T_F = 25\text{ }^\circ\text{C}$ | 250 | W |
| $E_{AS}^{(2)}$ | Single pulse avalanche energy | 495 | mJ |
| T_J | Operating junction temperature | -55 to 175 | $^\circ\text{C}$ |
| T_{stg} | Storage temperature | | $^\circ\text{C}$ |

1. Pulse width is limited by safe operating area
2. Starting $T_j=25\text{ }^\circ\text{C}$, $I_D=30\text{ A}$, $V_{DD}=50\text{ V}$

Table 3. Thermal data

| Symbol | Parameter | Value | Unit |
|---------------------|--------------------------------------|-------|--------------------|
| $R_{thj-case}$ | Thermal resistance junction-case max | 0.6 | $^\circ\text{C/W}$ |
| $R_{thj-pcb}^{(1)}$ | Thermal resistance junction-pcb max | 35 | $^\circ\text{C/W}$ |

1. When mounted on 1 inch² FR-4 board, 2 oz Cu

2 Electrical characteristics

($T_C = 25\text{ °C}$ unless otherwise specified)

Table 4. On /off states

| Symbol | Parameter | Test conditions | Min. | Typ. | Max. | Unit |
|---------------|-----------------------------------|--|------|--------|--------|---------------|
| $V_{(BR)DSS}$ | Drain-source breakdown voltage | $V_{GS} = 0, I_D = 250\text{ }\mu\text{A}$ | 100 | | | V |
| I_{DSS} | Zero gate voltage drain current | $V_{GS} = 0, V_{DS} = 100\text{ V}$ | | | 1 | μA |
| | | $V_{GS} = 0, V_{DS} = 100\text{ V}, T_C = 125\text{ °C}$ | | | 100 | μA |
| I_{GSS} | Gate-body leakage current | $V_{DS} = 0, V_{GS} = +20\text{ V}$ | | | 100 | nA |
| $V_{GS(th)}$ | Gate threshold voltage | $V_{DS} = V_{GS}, I_D = 250\text{ }\mu\text{A}$ | 2.5 | | 4.5 | V |
| $R_{DS(on)}$ | Static drain-source on-resistance | $V_{GS} = 10\text{ V}, I_D = 55\text{ A}$ | | 0.0034 | 0.0039 | \square |

Table 5. Dynamic

| Symbol | Parameter | Test conditions | Min. | Typ. | Max. | Unit |
|-----------|------------------------------|--|------|------|------|------|
| C_{iss} | Input capacitance | $V_{DS} = 50\text{ V}, f = 1\text{ MHz}, V_{GS} = 0$ | - | 8115 | - | pF |
| C_{oss} | Output capacitance | | - | 1510 | - | pF |
| C_{rss} | Reverse transfer capacitance | | - | 67 | - | pF |
| Q_g | Total gate charge | $V_{DD} = 50\text{ V}, I_D = 110\text{ A}, V_{GS} = 10\text{ V}$ (see Figure 14) | - | 117 | - | nC |
| Q_{gs} | Gate-source charge | | - | 47 | - | nC |
| Q_{gd} | Gate-drain charge | | - | 26 | - | nC |

Table 6. Switching times

| Symbol | Parameter | Test conditions | Min. | Typ. | Max. | Unit |
|--------------|---------------------|---|------|------|------|------|
| $t_{d(on)}$ | Turn-on delay time | $V_{DD} = 50\text{ V}, I_D = 55\text{ A}, R_G = 4.7\text{ }\square, V_{GS} = 10\text{ V}$ (see Figure 13) | - | 33 | - | ns |
| t_r | Rise time | | - | 57 | - | ns |
| $t_{d(off)}$ | Turn-off delay time | | - | 72 | - | ns |
| t_f | Fall time | | - | 33 | - | ns |

Table 7. Source drain diode

| Symbol | Parameter | Test conditions | Min. | Typ. | Max. | Unit |
|-----------------|-------------------------------|--|------|------|------|------|
| I_{SD} | Source-drain current | | - | | 110 | A |
| $I_{SDM}^{(1)}$ | Source-drain current (pulsed) | | - | | 440 | A |
| $V_{SD}^{(2)}$ | Forward on voltage | $I_{SD} = 110 \text{ A}$, $V_{GS} = 0$ | - | | 1.2 | V |
| t_{rr} | Reverse recovery time | $I_{SD} = 110 \text{ A}$, $di/dt = 100 \text{ A}/\mu\text{s}$ | - | 70 | | ns |
| Q_{rr} | Reverse recovery charge | $V_{DD} = 80 \text{ V}$, $T_J = 150 \text{ }^\circ\text{C}$ (see Figure 15) | - | 165 | | nC |
| I_{RRM} | Reverse recovery current | | - | 4.7 | | A |

1. Pulse width limited by safe operating area
2. Pulsed: pulse duration = 300 μs , duty cycle 1.5%.

2.1 Electrical characteristics (curves)

Figure 2. Safe operating area

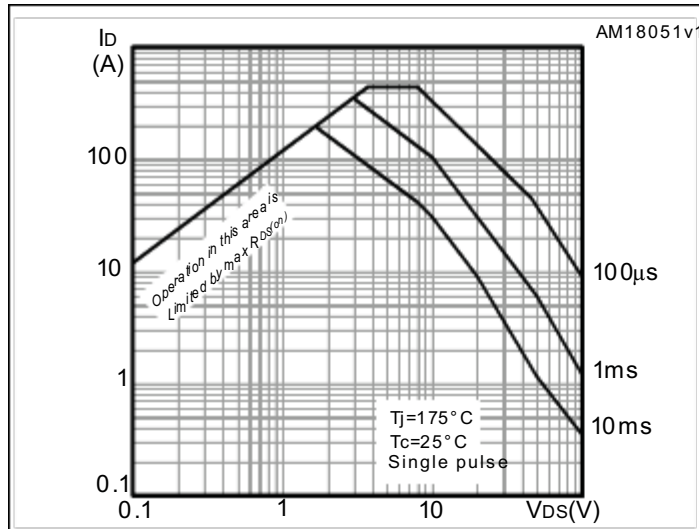

Figure 3. Thermal impedance

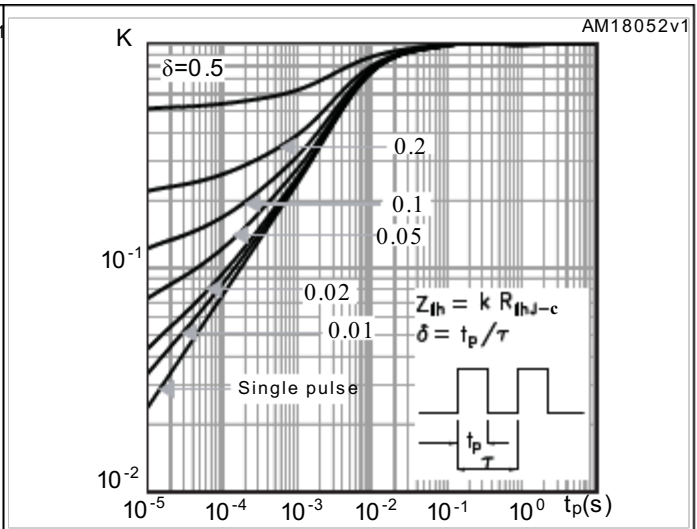

Figure 4. Output characteristics

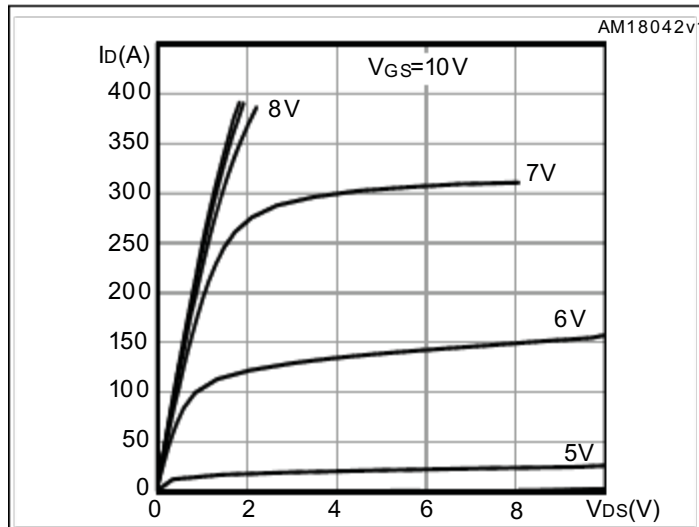

Figure 5. Transfer characteristics

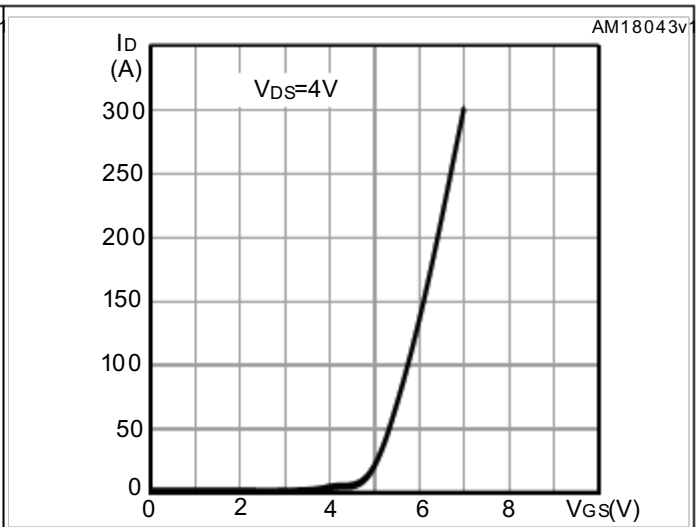

Figure 6. Gate charge vs gate-source voltage

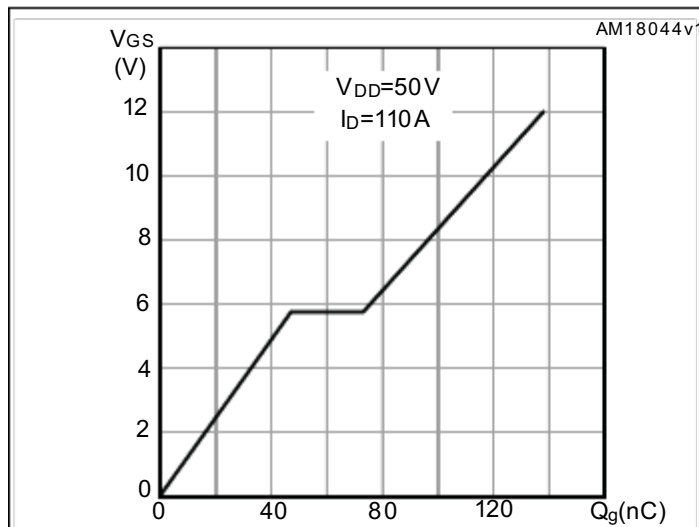

Figure 7. Static drain-source on-resistance

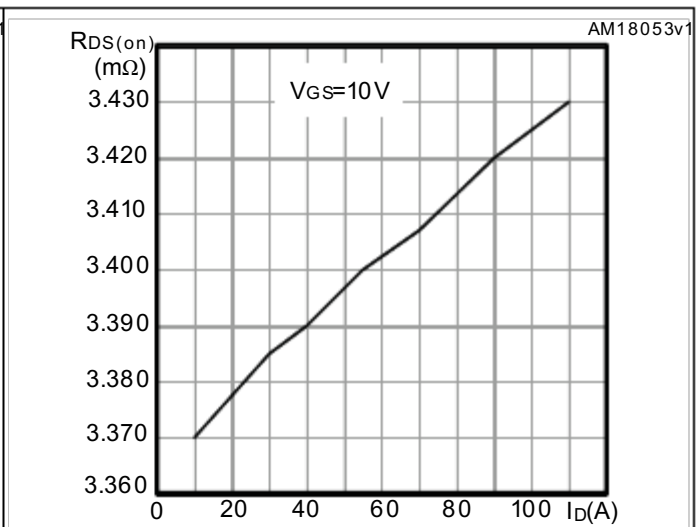

Figure 8. Capacitance variations

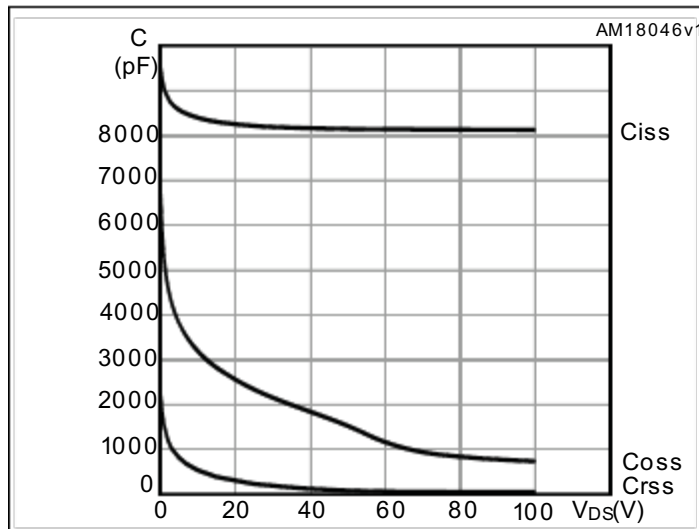

Figure 9. Normalized gate threshold voltage vs temperature

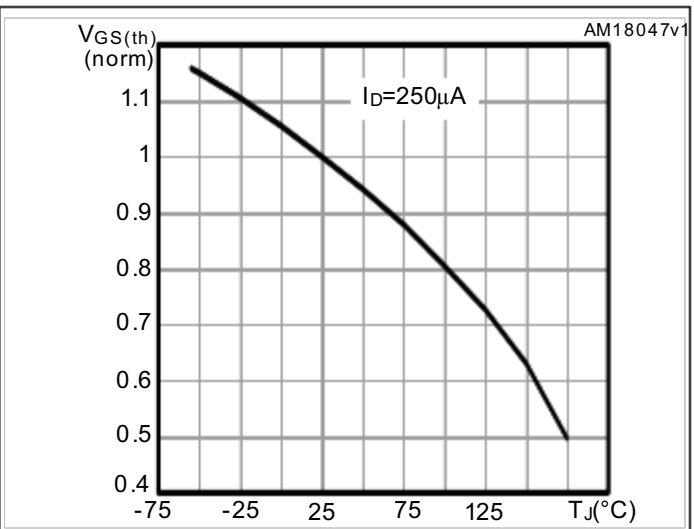

Figure 10. Normalized on-resistance vs temperature

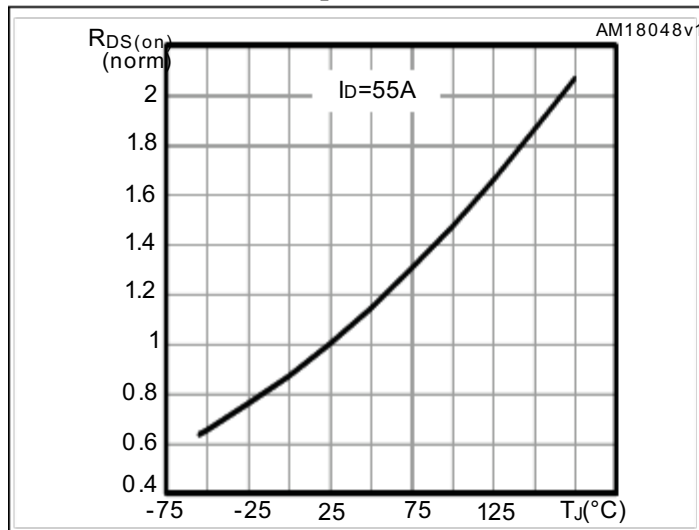

Figure 11. Normalized VDS vs temperature

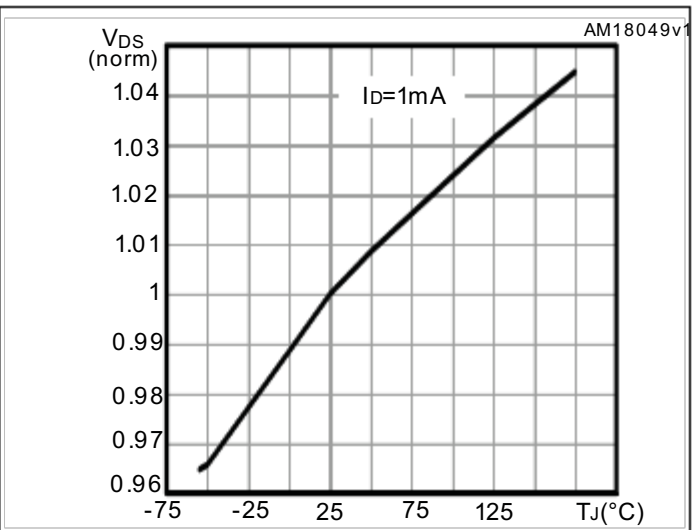
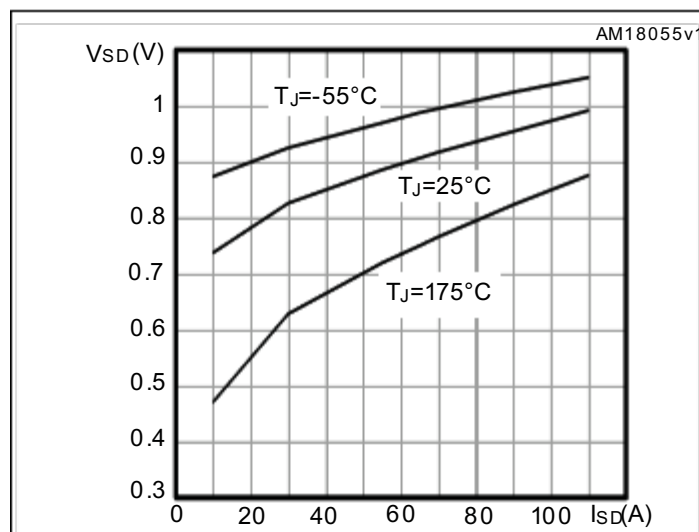

Figure 12. Source-drain diode forward characteristics



3 Test circuits

Figure 13. Switching times test circuit for resistive load

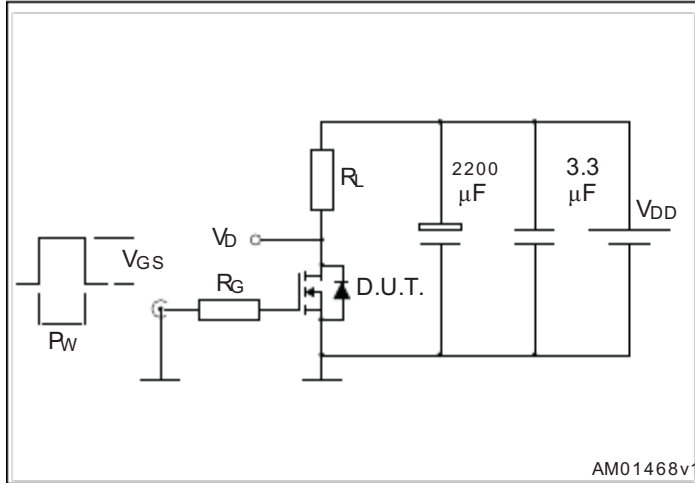

Figure 14. Gate charge test circuit

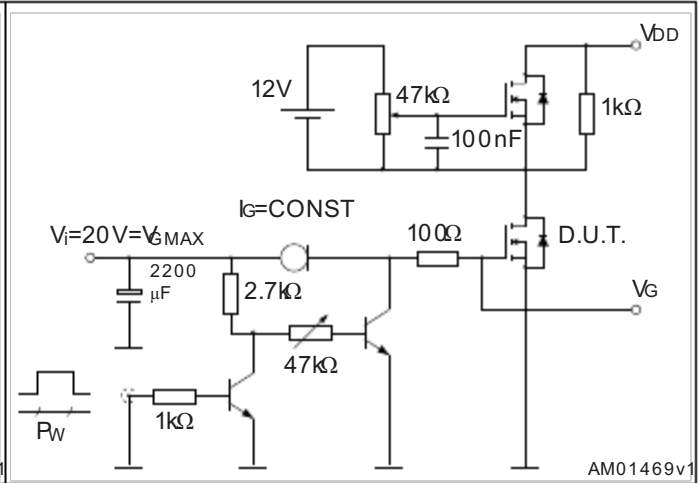

Figure 15. Test circuit for inductive load switching and diode recovery times

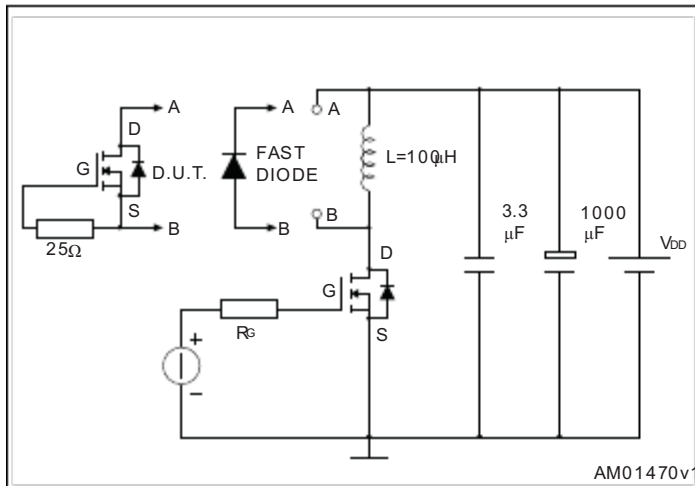

Figure 16. Unclamped inductive load test circuit

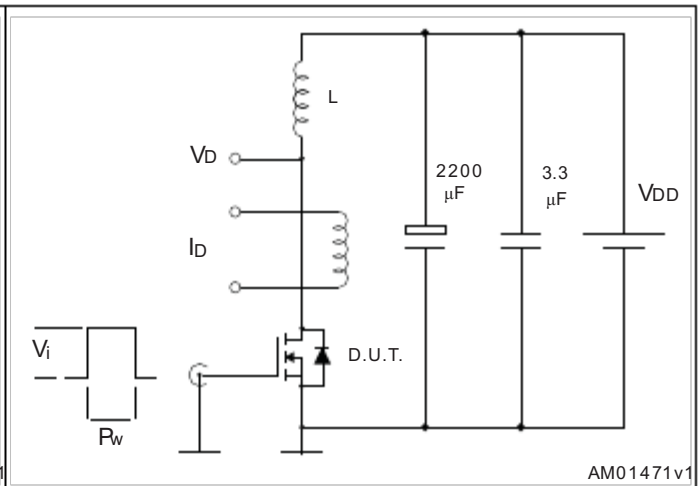

Figure 17. Unclamped inductive waveform

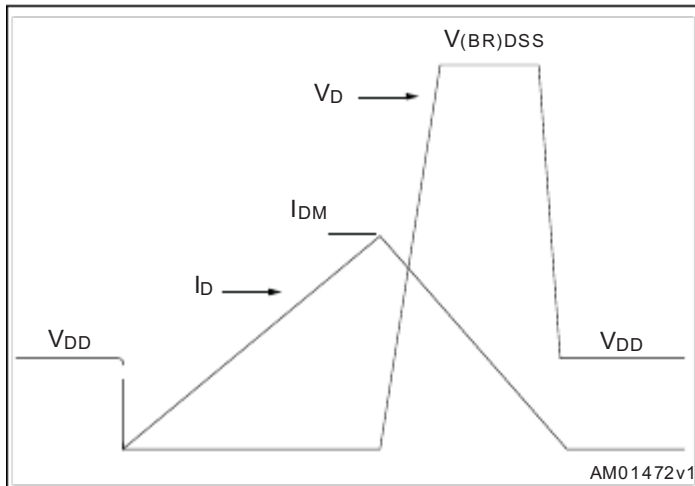
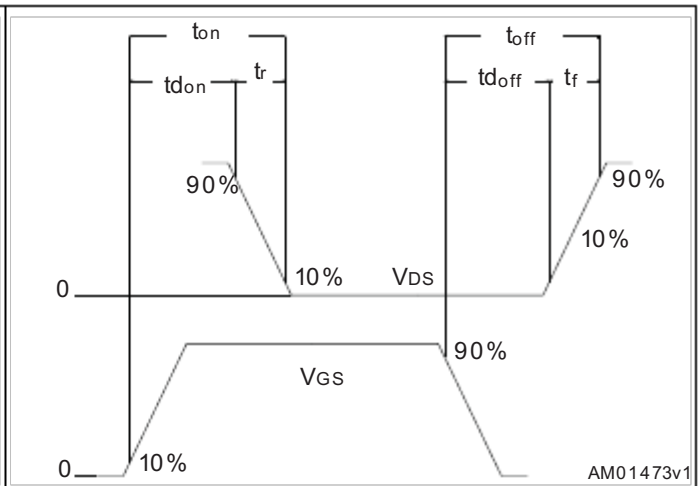

Figure 18. Switching time waveform



4 Package mechanical data

In order to meet environmental requirements, ST offers these devices in different grades of ECOPACK[®] packages, depending on their level of environmental compliance. ECOPACK[®] specifications, grade definitions and product status are available [at www.st.com](http://www.st.com). ECOPACK[®] is an ST trademark.

Figure 19. H²PAK-2 drawing

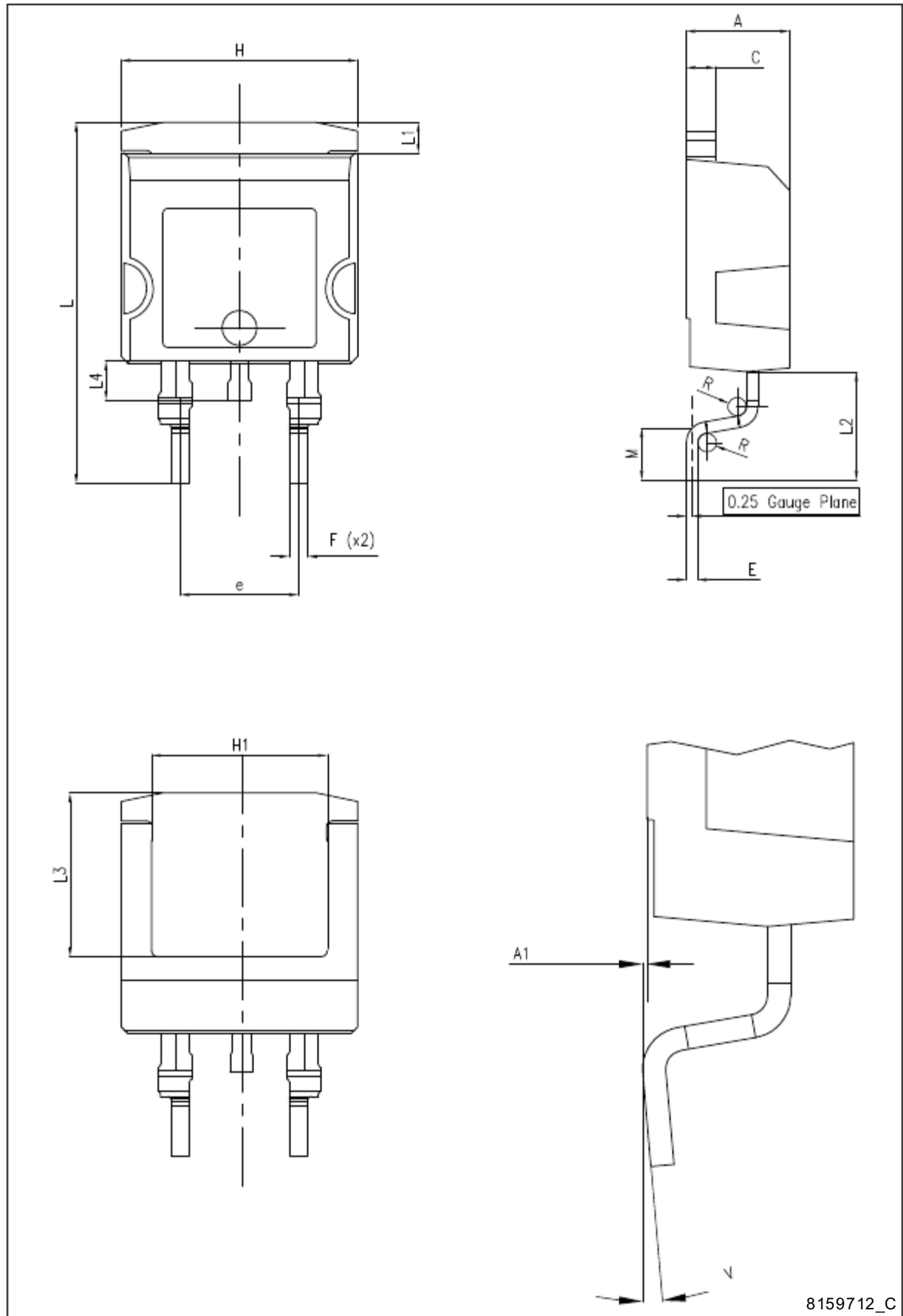
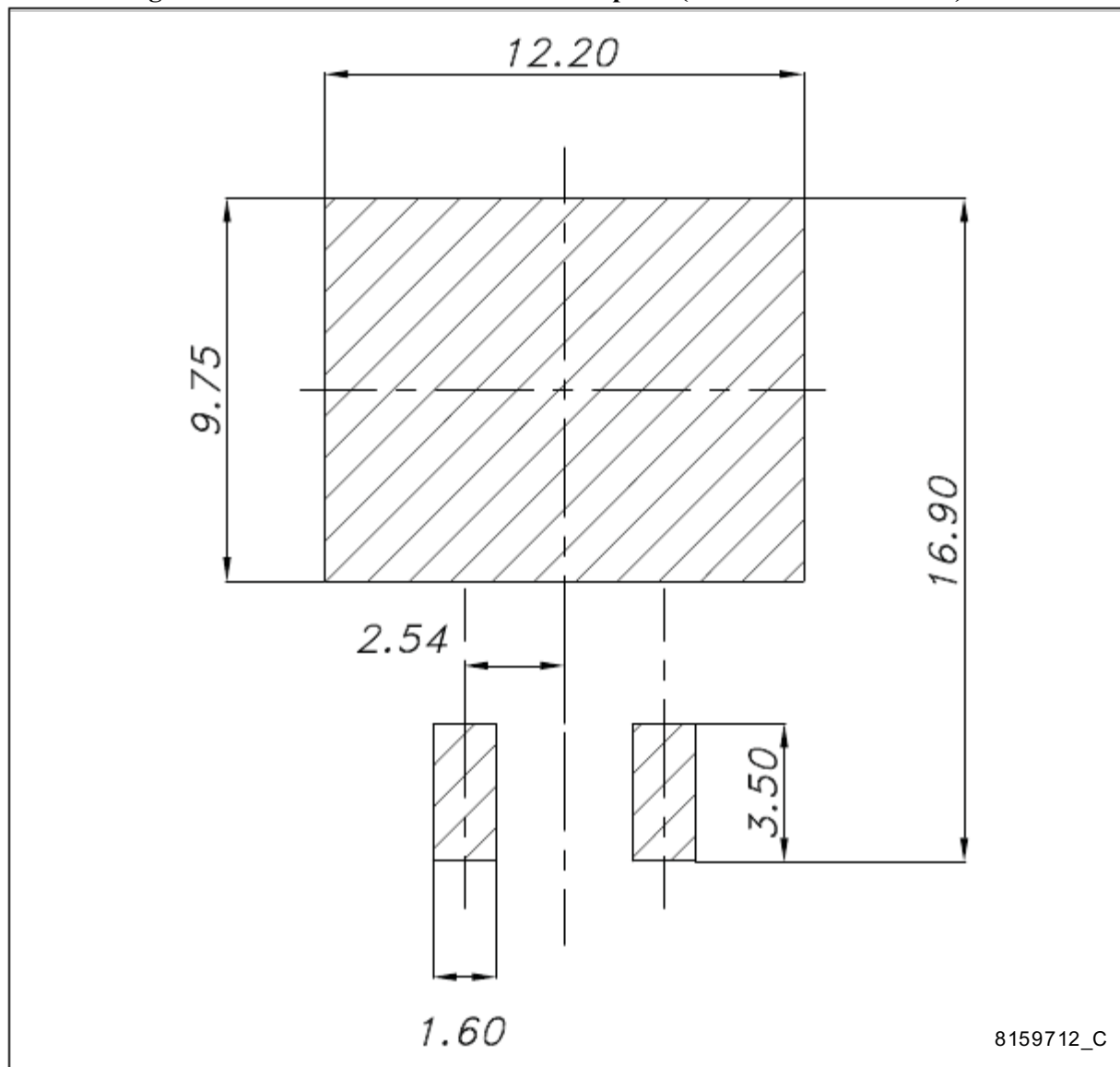

Table 8. H²PAK-2 mechanical data

| Dim. | mm | | |
|------|-------|------|-------|
| | Min. | Typ. | Max. |
| A | 4.30 | - | 4.80 |
| A1 | 0.03 | | 0.20 |
| C | 1.17 | | 1.37 |
| e | 4.98 | | 5.18 |
| E | 0.50 | | 0.90 |
| F | 0.78 | | 0.85 |
| H | 10.00 | | 10.40 |
| H1 | 7.40 | | 7.80 |
| L | 15.30 | | 15.80 |
| L1 | 1.27 | | 1.40 |
| L2 | 4.93 | | 5.23 |
| L3 | 6.85 | | 7.25 |
| L4 | 1.5 | | 1.7 |
| M | 2.6 | | 2.9 |
| R | 0.20 | | 0.60 |
| V | 0° | | 8° |

Figure 20. H²PAK-2 recommended footprint (dimensions are in mm)



8159712_C

5 Packaging mechanical data

Table 9. H²PAK-2 tape and reel mechanical data

| Tape | | | Reel | | |
|------|------|------|----------|------|------|
| Dim. | mm | | Dim. | mm | |
| | Min. | Max. | | Min. | Max. |
| A0 | 10.5 | 10.7 | A | | 330 |
| B0 | 15.7 | 15.9 | B | 1.5 | |
| D | 1.5 | 1.6 | C | 12.8 | 13.2 |
| D1 | 1.59 | 1.61 | D | 20.2 | |
| E | 1.65 | 1.85 | G | 24.4 | 26.4 |
| F | 11.4 | 11.6 | N | 100 | |
| K0 | 4.8 | 5.0 | T | | 30.4 |
| P0 | 3.9 | 4.1 | | | |
| P1 | 11.9 | 12.1 | Base qty | | 1000 |
| P2 | 1.9 | 2.1 | Bulk qty | | 1000 |
| R | 50 | | | | |
| T | 0.25 | 0.35 | | | |
| W | 23.7 | 24.3 | | | |

Figure 21. Tape

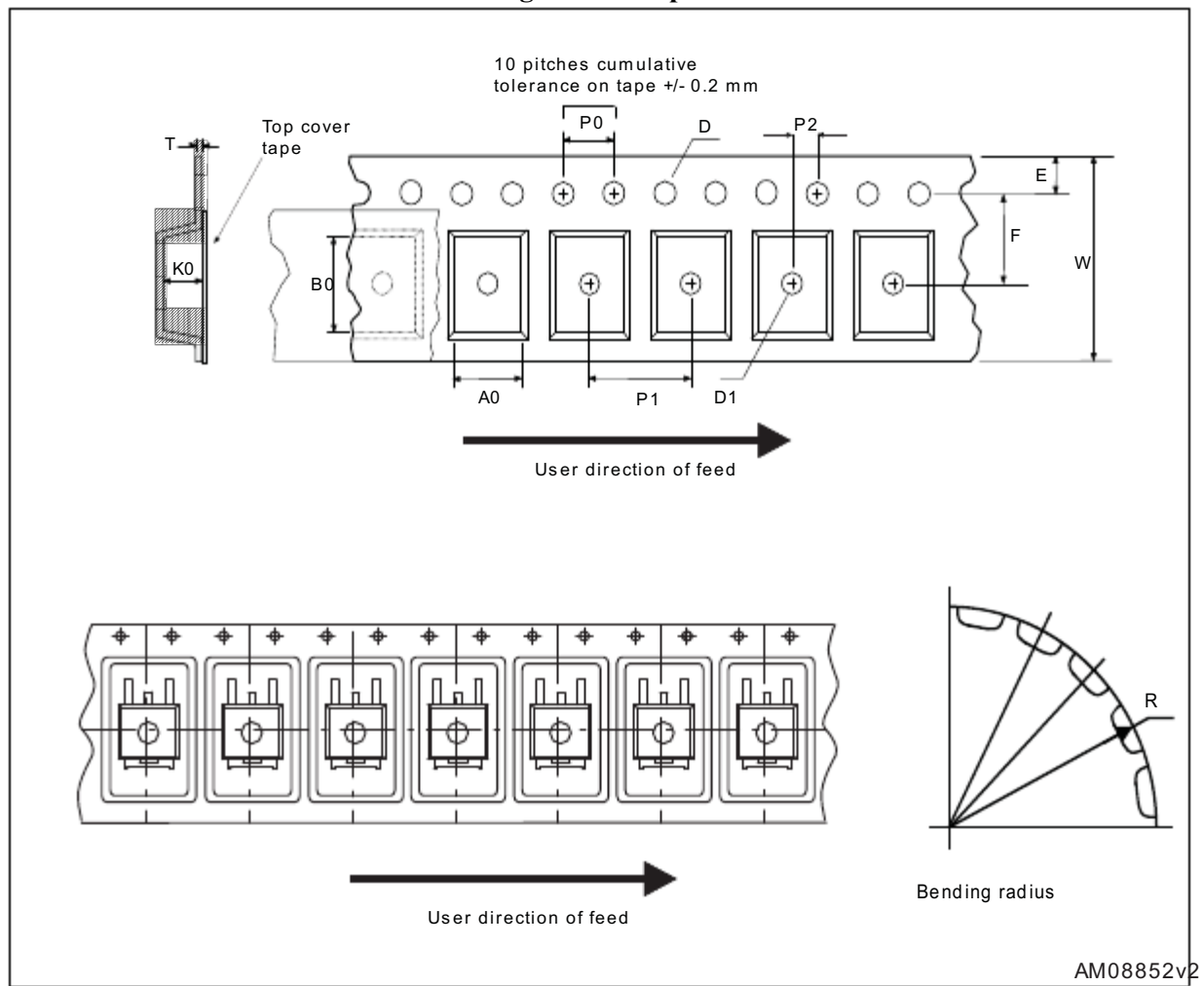
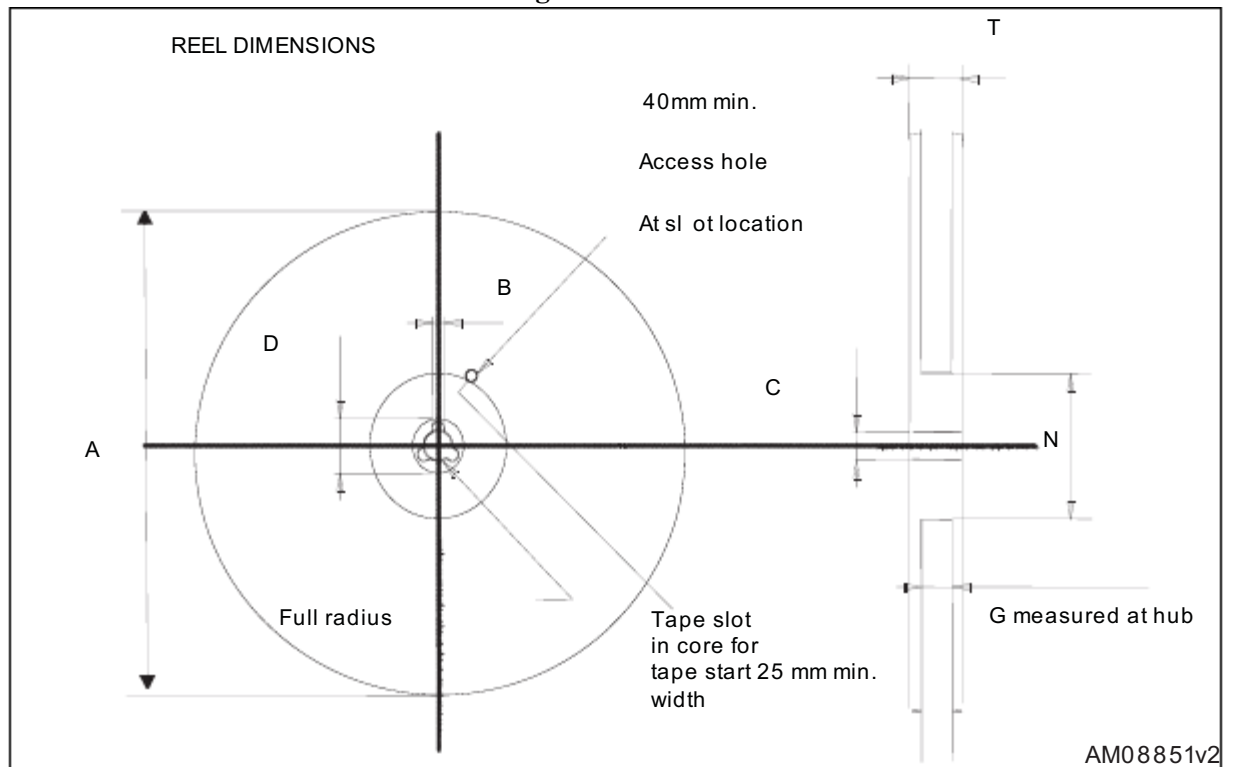

Figure 22. Reel



6 Revision history

Table 10. Document revision history

| Date | Revision | Changes |
|-------------|----------|--|
| 22-Jan-2014 | 1 | First release. The part number previously included in datasheet DocID024972 |
| 25-Aug-2014 | 2 | Updated title and description in cover page. Added E_{AS} parameter in Table 2: Absolute maximum ratings . Minor text changes. |

IMPORTANT NOTICE – PLEASE READ CAREFULLY

STMicroelectronics NV and its subsidiaries ("ST") reserve the right to make changes, corrections, enhancements, modifications, and improvements to ST products and/or to this document at any time without notice. Purchasers should obtain the latest relevant information on ST products before placing orders. ST products are sold pursuant to ST's terms and conditions of sale in place at the time of order acknowledgement.

Purchasers are solely responsible for the choice, selection, and use of ST products and ST assumes no liability for application assistance or the design of Purchasers' products.

No license, express or implied, to any intellectual property right is granted by ST herein.

Resale of ST products with provisions different from the information set forth herein shall void any warranty granted by ST for such product.

ST and the ST logo are trademarks of ST. All other product or service names are the property of their respective owners.

Information in this document supersedes and replaces information previously supplied in any prior versions of this document.

© 2014 STMicroelectronics – All rights reserved



单击下面可查看定价，库存，交付和生命周期等信息

[>>STMicroelectronics\(意法半导体\)](#)