

Introduction

The STM32F4DISCOVERY Discovery kit allows users to easily develop applications with the STM32F407VG high performance microcontroller with the ARM® Cortex®-M4 32-bit core. It includes everything required either for beginners or for experienced users to get quickly started.

Based on STM32F407VG, it includes an ST-LINK/V2 or ST-LINK/V2-A embedded debug tool, two ST-MEMS digital accelerometers, a digital microphone, one audio DAC with integrated class D speaker driver, LEDs, push buttons and a USB OTG micro-AB connector. To expand the functionality of the STM32F4DISCOVERY Discovery kit with the Ethernet connectivity, LCD display and more, visit the www.st.com/stm32f4dis-expansion webpage. The STM32F4DISCOVERY Discovery kit comes with the STM32 comprehensive free software libraries and examples available with the STM32Cube package, as well as a direct access to the ARM® mbed Enabled™ on-line resources at <http://mbed.org>.

Figure 1. STM32F4DISCOVERY

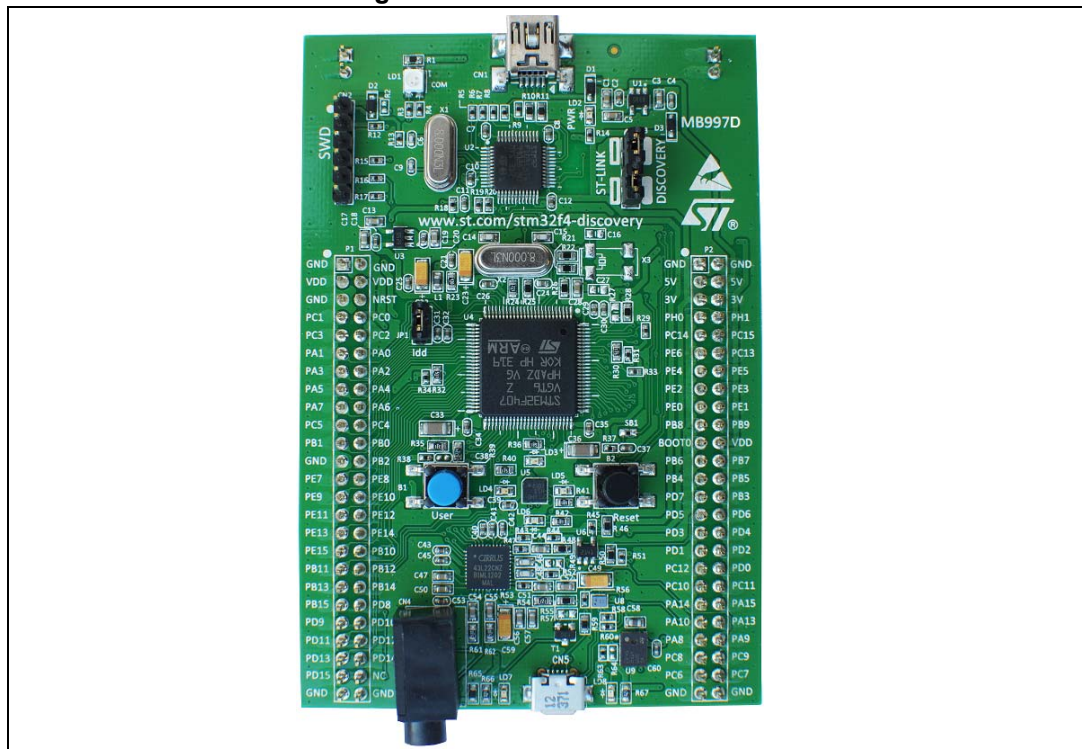

1. Picture is not contractual.



Contents

- 1 Features 6**
- 2 Product marking 7**
- 3 Ordering information 7**
- 4 Conventions 7**
- 5 Quick start 8**
 - 5.1 Getting started 8
 - 5.2 System requirements 8
 - 5.3 Development toolchains supported 8
- 6 Hardware and layout 9**
 - 6.1 Embedded ST-LINK/V2 (or V2-A) 11
 - 6.1.1 Drivers 12
 - 6.1.2 ST-LINK/V2 (or V2-A) firmware upgrade 13
 - 6.1.3 ST-LINK/V2-A VCP configuration 13
 - 6.1.4 Using ST-LINK/V2 (or V2-A) to program/debug
the STM32F407VG on board 14
 - 6.1.5 Using ST-LINK/V2 (or V2-A) to program/debug an external STM32
application 15
 - 6.2 Power supply and power selection 16
 - 6.3 LEDs 16
 - 6.4 Push buttons 16
 - 6.5 On-board audio capability 17
 - 6.6 USB OTG supported 17
 - 6.7 Motion sensor (ST-MEMS LIS302DL or LIS3DSH) 17
 - 6.8 JP1 (Idd) 18
 - 6.9 OSC clock 18
 - 6.9.1 OSC clock supply 18
 - 6.9.2 OSC 32 KHz clock supply 18
 - 6.10 Solder bridges 19
 - 6.11 Extension connectors 19



7	Electrical schematics	26
8	Mechanical drawing	32
9	Revision history	33

List of tables

Table 1.	List of the order codes	7
Table 2.	ON/OFF conventions	7
Table 3.	Jumper states	12
Table 4.	Debug connector CN2 (SWD)	15
Table 5.	Solder bridges	19
Table 6.	STM32 pin description versus board functions	20
Table 7.	Document revision history	33

List of figures

Figure 1.	STM32F4DISCOVERY	1
Figure 2.	Hardware block diagram	9
Figure 3.	STM32F4DISCOVERY top layout	10
Figure 4.	STM32F4DISCOVERY bottom layout	11
Figure 5.	USB composite device	12
Figure 6.	ST-LINK VCP connection to USART2	13
Figure 7.	STM32F4DISCOVERY connections	14
Figure 8.	ST-LINK connections	15
Figure 9.	STM32F407G-DISC1	26
Figure 10.	ST-LINK/V2 (SWD only)	27
Figure 11.	MCU	28
Figure 12.	Audio	29
Figure 13.	USB_OTG_FS	30
Figure 14.	Peripherals	31
Figure 15.	STM32F4DISCOVERY mechanical drawing	32

1 Features

The STM32F4DISCOVERY offers the following features:

- STM32F407VGT6 microcontroller featuring 32-bit ARM Cortex[®]-M4 with FPU core, 1-Mbyte Flash memory, 192-Kbyte RAM in an LQFP100 package
- On-board ST-LINK/V2 on STM32F4DISCOVERY or ST-LINK/V2-A on STM32F407G-DISC1
- ARM[®] mbed Enabled[™] (<http://mbed.org>) with ST-LINK/V2-A only
- USB ST-LINK with re-enumeration capability and three different interfaces:
 - Virtual COM port (with ST-LINK/V2-A only)
 - Mass storage (with ST-LINK/V2-A only)
 - Debug port
- Board power supply:
 - Through USB bus
 - External power sources:
3 V and 5 V
- LIS302DL or LIS3DSH ST MEMS 3-axis accelerometer
- MP45DT02 ST MEMS audio sensor omni-directional digital microphone
- CS43L22 audio DAC with integrated class D speaker driver
- Eight LEDs:
 - LD1 (red/green) for USB communication
 - LD2 (red) for 3.3 V power on
 - Four user LEDs, LD3 (orange), LD4 (green), LD5 (red) and LD6 (blue)
 - 2 USB OTG LEDs LD7 (green) VBUS and LD8 (red) over-current
- Two push buttons (user and reset)
- USB OTG FS with micro-AB connector
- Extension header for all LQFP100 I/Os for quick connection to prototyping board and easy probing
- Comprehensive free software including a variety of examples, part of the STM32CubeF4 package or STSW-STM32068 for legacy standard library usage

2 Product marking

Tools marked as "ES" or "E" are not yet qualified and as such, they may be used only for evaluation purposes. ST shall not be liable for any consequences related with other ways of use of such non-qualified tools, for example, as reference design or for production.

Examples of location of "E" or "ES" marking:

- On target STM32 microcontroller part mounted on the board (for illustration, refer to section "Package information" of a STM32 datasheet at www.st.com).
- Next to the evaluation tool ordering part number, as a label stuck or a silk-screen printed on the board.

3 Ordering information

To order the Discovery kit for the STM32F407 line of microcontrollers, refer to [Table 1](#).

Table 1. List of the order codes

Order code	ST-LINK version
STM32F4DISCOVERY	ST-LINK/V2
STM32F407G-DISC1	ST-LINK/V2-A (mbed Enabled)

4 Conventions

[Table 2](#) provides the definition of some conventions used in the present document.

Table 2. ON/OFF conventions

Convention	Definition
Jumper JP1 ON	Jumper fitted
Jumper JP1 OFF	Jumper not fitted
Solder bridge SBx ON	SBx connections closed by solder
Solder bridge SBx OFF	SBx connections left open

5 Quick start

The STM32F4DISCOVERY is a low-cost and easy-to-use development kit to quickly evaluate and start a development with an STM32F407VG high-performance microcontroller.

Before installing and using the product, accept the Evaluation Product License Agreement from the www.st.com/stm32f4-discovery webpage.

For more information on the STM32F4DISCOVERY and for demonstration software, visit the www.st.com/stm32f4-discovery webpage.

5.1 Getting started

Follow the sequence below to configure the STM32F4DISCOVERY board and launch the DISCOVER application:

1. Check jumper position on the board, JP1 on, CN3 on (DISCOVERY selected).
2. Connect the STM32F4DISCOVERY board to a PC with a USB cable 'type A to mini-B' through USB connector CN1 to power the board. Red LED LD2 (PWR) then lights up.
3. Four LEDs between B1 and B2 buttons are blinking.
4. Press user button B1 to enable the ST MEMS sensor, move the board and observe the four LEDs blinking according to the motion direction and speed. (If a second USB cable 'type A to micro-B' is connected between PC and CN5 connector, then the board is recognized as standard mouse and its motion will also control the PC cursor).
5. To study or modify the DISCOVER project related to this demonstration, visit the www.st.com/stm32f4-discovery webpage and follow the tutorial.
6. Discover the STM32F407VG features, download and execute programs proposed in the list of projects.
7. Develop the application using available examples.

5.2 System requirements

- Windows® OS (XP, 7, 8 and 10), Linux® 64-bit or macOS™
- USB type A to Mini-B cable.

5.3 Development toolchains supported

- Keil® MDK-ARM^(a)
- IAR™ EWARM^(a)
- GCC-based IDEs including free SW4STM32 from AC6
- ARM® mbed Enabled™ online

a. On Windows® only.

6 Hardware and layout

The STM32F4DISCOVERY is designed around the STM32F407VGT6 microcontroller in a 100-pin LQFP package.

Figure 2 illustrates the connections between the STM32F407VGT6 and its peripherals (ST-LINK/V2 or ST-LINK/V2-A, push buttons, LEDs, Audio DAC, USB, ST-MEMS accelerometer and microphone, and connectors).

Figure 3 and *Figure 4* help users to locate these features on the STM32F4DISCOVERY board.

Figure 2. Hardware block diagram

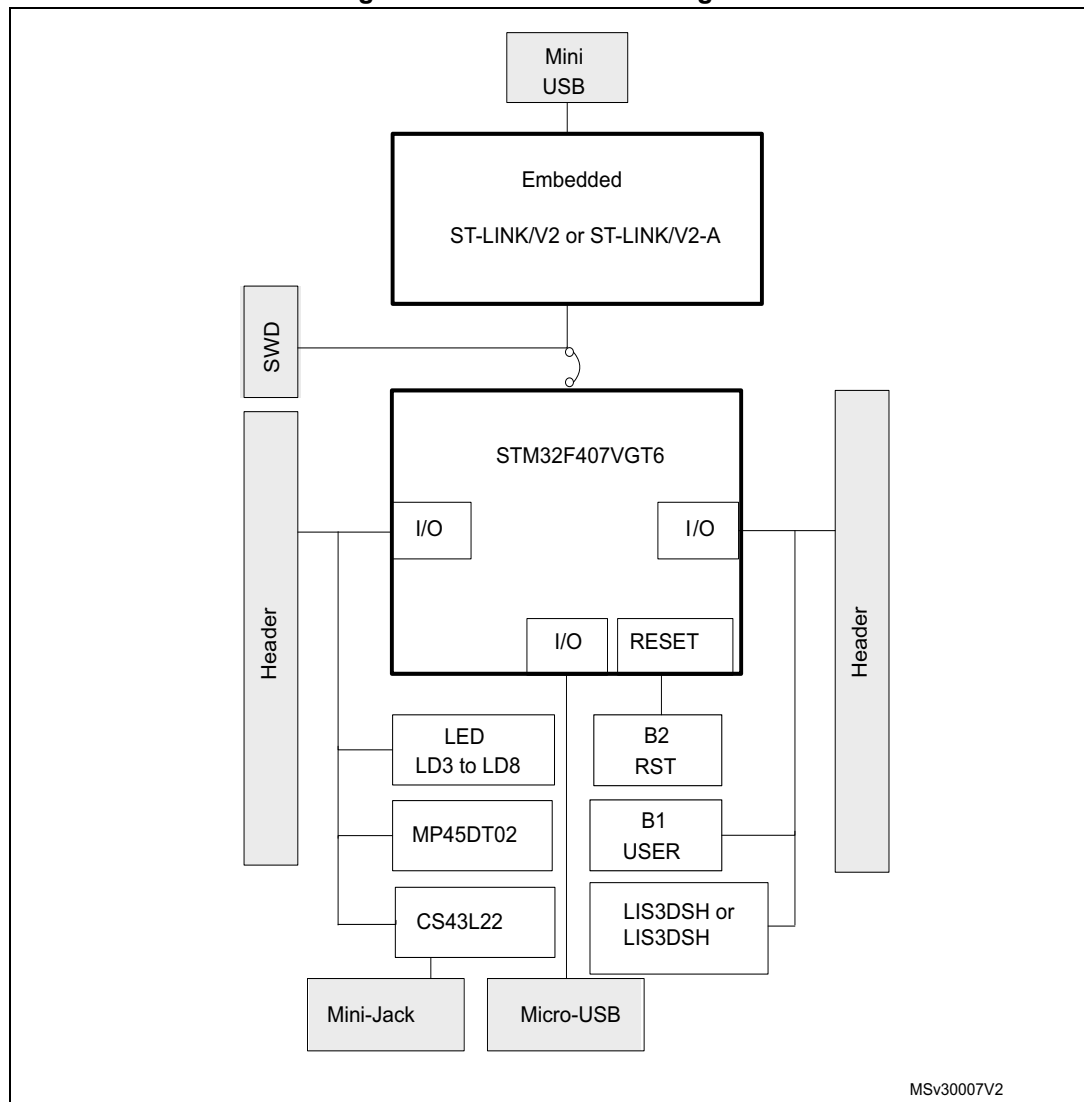
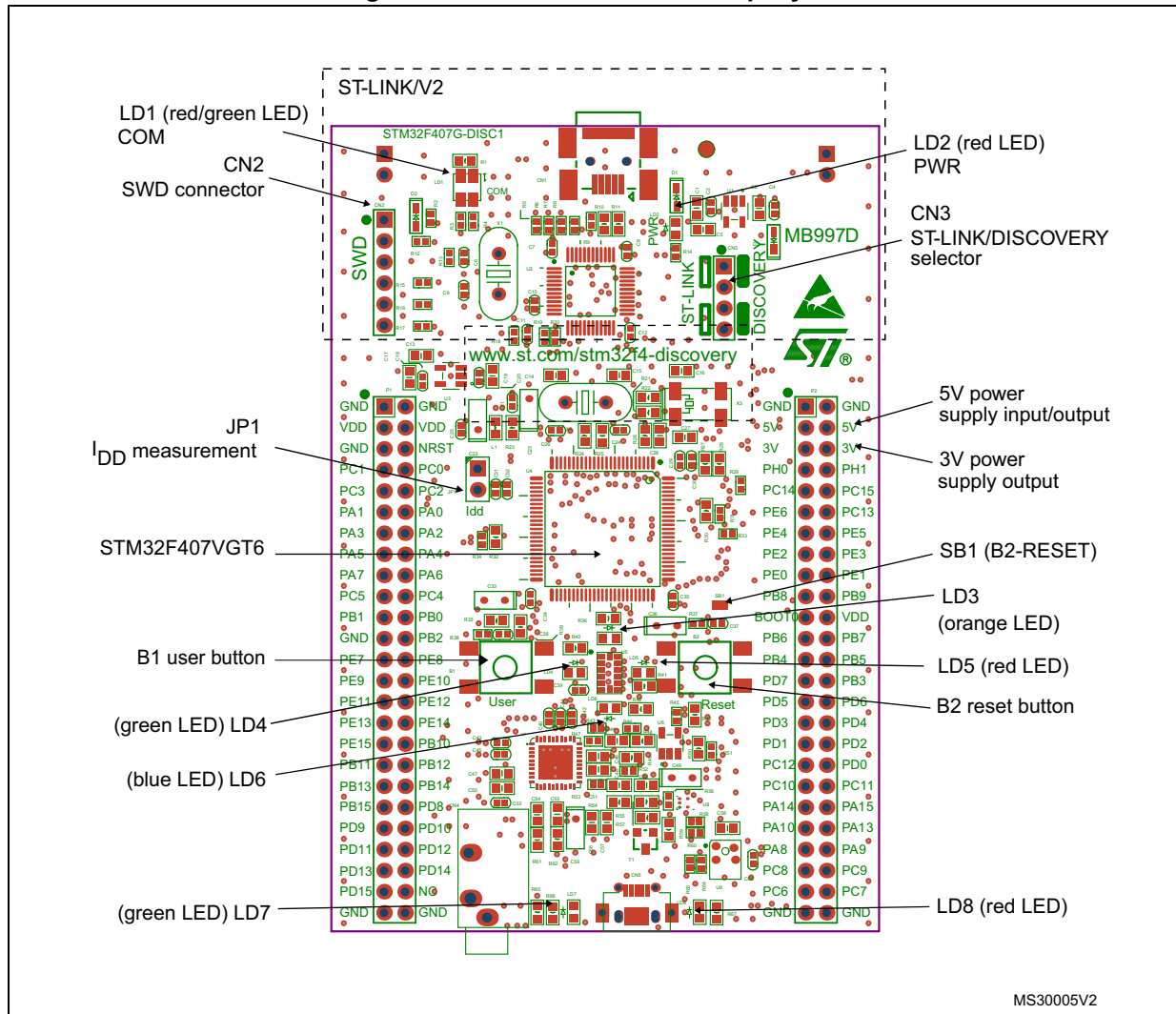
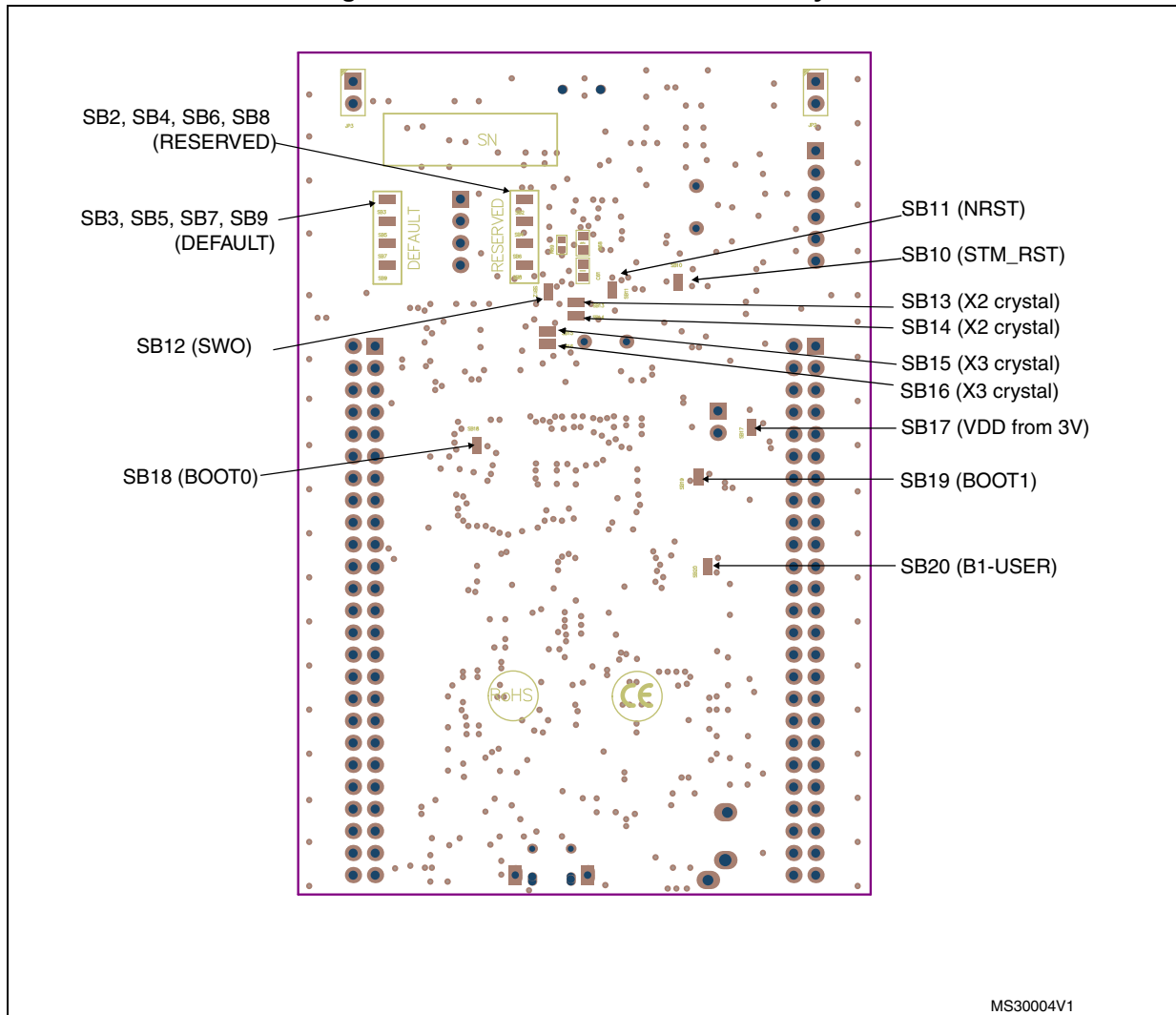

Figure 3. STM32F4DISCOVERY top layout



Note: Pin 1 of CN2, CN3, JP1, P1 and P2 connectors are identified by a red square.

Figure 4. STM32F4DISCOVERY bottom layout



6.1 Embedded ST-LINK/V2 (or V2-A)

ST-LINK/V2 on STM32F4DISCOVERY or ST-LINK/V2-A on STM32F407G-DISC1 is an embedded tool for programming and debugging.

The embedded ST-LINK/V2 (or V2-A) supports only SWD for STM32 devices. For information about debugging and programming features refer to *ST-LINK/V2 in-circuit debugger/programmer for STM8 and STM32*, UM1075 User manual, which describes in details all the ST-LINK/V2 features.

The changes on ST-LINK/V2-A versus ST-LINK/V2 version are listed below.

New features supported on ST-LINK/V2-A:

- Virtual COM port interface on USB (see [Section 6.1.3: ST-LINK/V2-A VCP configuration](#))
- Mass storage interface on USB

Features not supported on ST-LINK/V2-A:

- SWIM interface
- Minimum supported application voltage limited to 3 V
- USB power management request for more than 100 mA power on USB

Known limitation:

- Activating the readout protection on ST-LINK/V2-A target, prevents the target application from running afterwards. The target readout protection must be kept disabled on ST-LINK/V2-A boards.

There are two different ways to use the embedded ST-LINK/V2 (or V2-A) depending on the jumper states (see [Table 3](#)):

- Program/debug the STM32 on board (refer to [Section 6.1.4: Using ST-LINK/V2 \(or V2-A\) to program/debug the STM32F407VG on board](#))
- Program/debug the STM32 in an external application board, using a cable connected to SWD connector CN2 (refer to [Section 6.1.5: Using ST-LINK/V2 \(or V2-A\) to program/debug an external STM32 application](#))

Table 3. Jumper states

Jumper state	Description
Both CN3 jumpers ON	ST-LINK/V2 (or V2-A) functions enabled for on board programming (default)
Both CN3 jumpers OFF	ST-LINK/V2 (or V2-A) functions enabled for application through external CN2 connector (SWD supported)

6.1.1 Drivers

Before connecting the STM32F4DISCOVERY board to a Windows® PC (XP, 7, 8 and 10) through the USB, a driver for the ST-LINK/V2 (or V2-A) must be installed. It is available at the www.st.com website. In case the STM32 Discovery is connected to the PC before the driver is installed, some Discovery interfaces may be declared as “Unknown” in the PC device manager. To recover from this situation, after installing the dedicated driver, the association of “Unknown” USB devices found on the STM32F4DISCOVERY board to this dedicated driver, must be updated in the device manager manually.

Note: It is recommended to proceed by using USB Composite Device, as shown in [Figure 5](#).

Figure 5. USB composite device

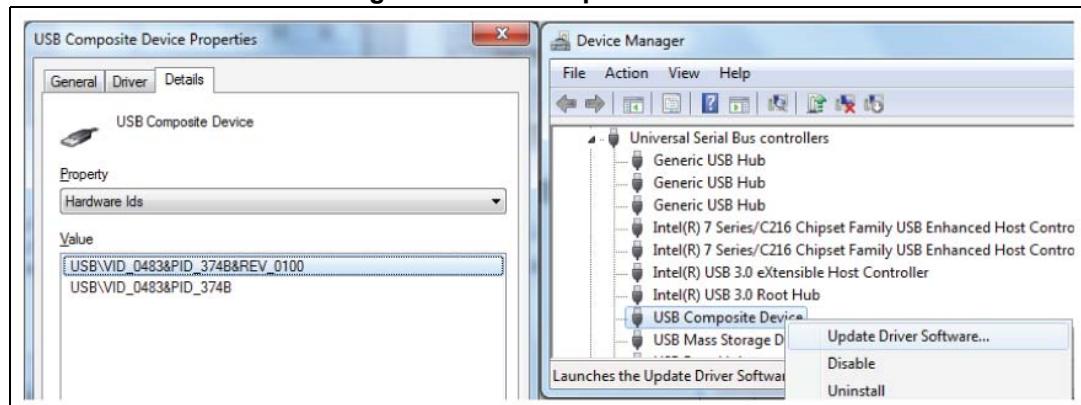

6.1.2 ST-LINK/V2 (or V2-A) firmware upgrade

The ST-LINK/V2 (or V2-A) embeds a firmware upgrade mechanism for in-situ upgrade through the USB port. As the firmware may evolve during the life time of the ST-LINK/V2 (or V2-A) product (for example new functionalities, bug fixes, support for new microcontroller families), it is recommended to visit the www.st.com website before starting to use the Discovery board and periodically, to stay up-to-date with the latest firmware version.

6.1.3 ST-LINK/V2-A VCP configuration

The ST-LINK/V2-A supports a virtual COM port (VCP) on U2 pin 12 (ST-LINK_TX) and U2 pin 13 (ST-LINK_RX) but these pins are not connected to the USART of the STM32F407 microcontroller for mbed support.

Two solutions are possible to connect an STM32F407 USART to the VCP on the PC:

- Using an USART to USB dongle from the market connected for instance to STM32F407 USART2 available on connector P1 pin 14 (PA2: USART2_TX) and P1 pin 13 (PA3: USART2_RX).
- Using flying wires to connect ST-LINK/V2-A virtual COM port (ST-LINK VCP on U2 pin 12 and 13) to STM32F407 USART2 (PA2 and PA3: P1 pin 14 and 13) as shown in the [Figure 6](#) below.

Figure 6. ST-LINK VCP connection to USART2

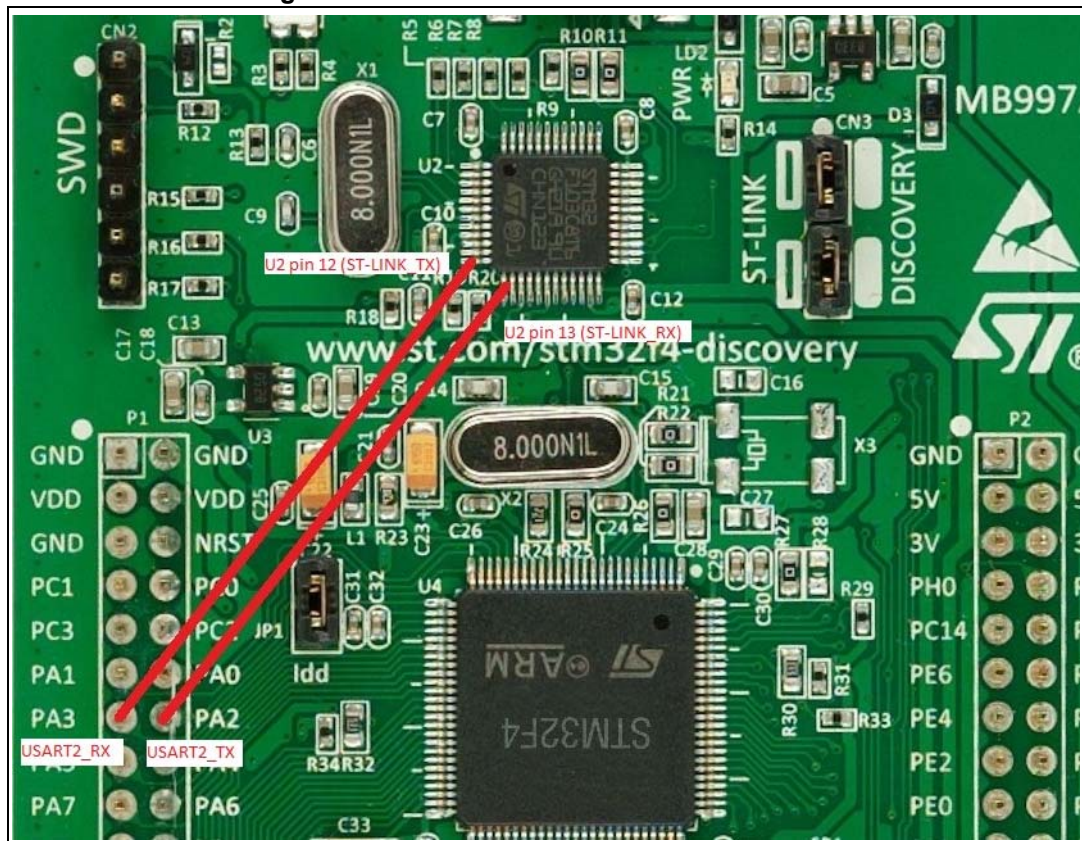

6.1.4 Using ST-LINK/V2 (or V2-A) to program/debug the STM32F407VG on board

To program the STM32F407VG on board, simply plug in the two jumpers on CN3, as shown in [Figure 7](#) in red, but do not use the CN2 connector as that could disturb communication with the STM32F407VG of the STM32F4DISCOVERY.

Figure 7. STM32F4DISCOVERY connections

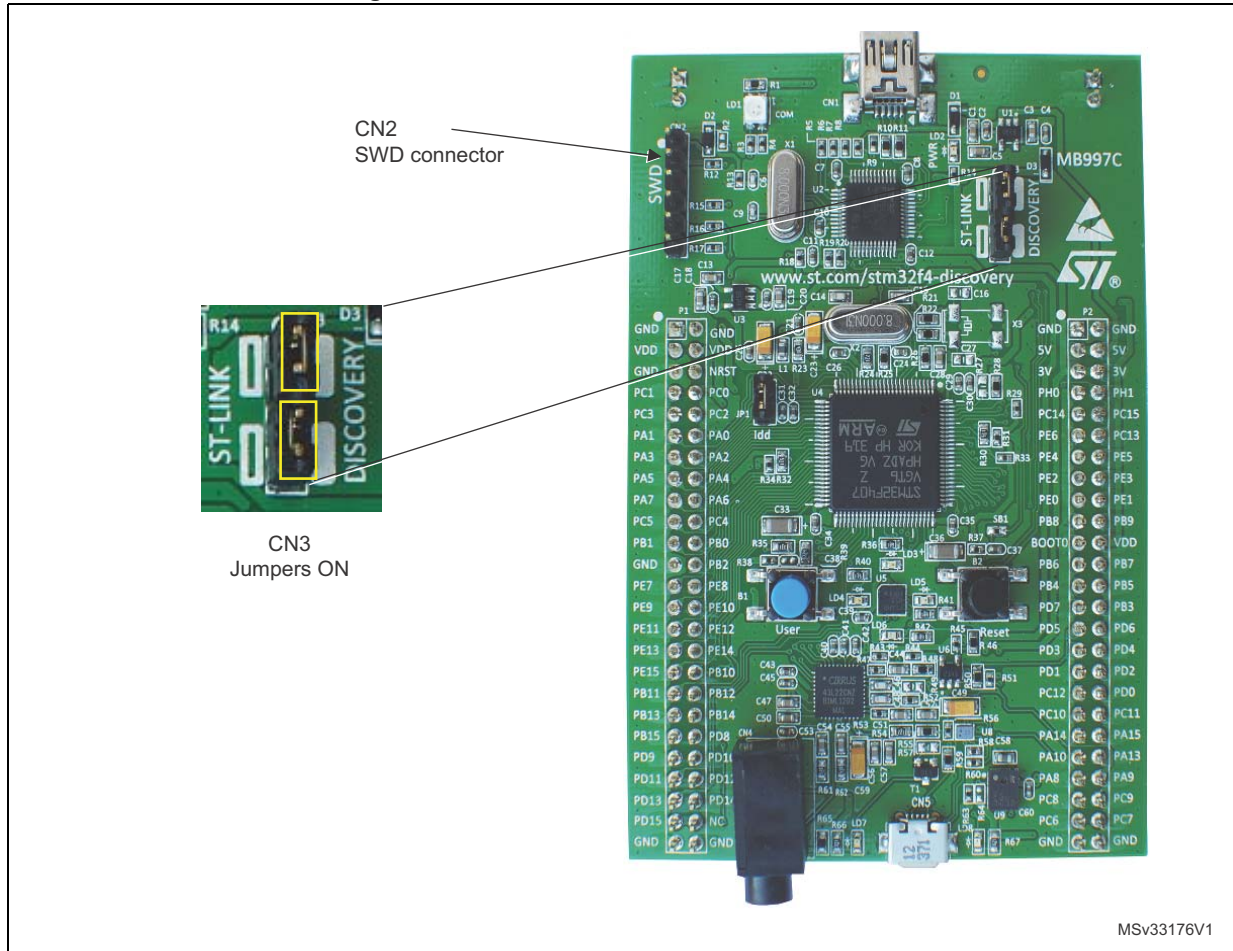

MSv33176V1

6.1.5 Using ST-LINK/V2 (or V2-A) to program/debug an external STM32 application

It is very easy to use the ST-LINK/V2 (or V2-A) to program the STM32 on an external application. Simply remove the two jumpers from CN3, as shown in *Figure 8*, and connect the application to the CN2 debug connector according to *Table 4*.

Note: SB11 must be OFF if CN2 pin 5 is used in the external application.

Table 4. Debug connector CN2 (SWD)

Pin	CN2	Designation
1	VDD_TARGET	VDD from application
2	SWCLK	SWD clock
3	GND	Ground
4	SWDIO	SWD data input/output
5	NRST	RESET of target STM32
6	SWO	Reserved

Figure 8. ST-LINK connections

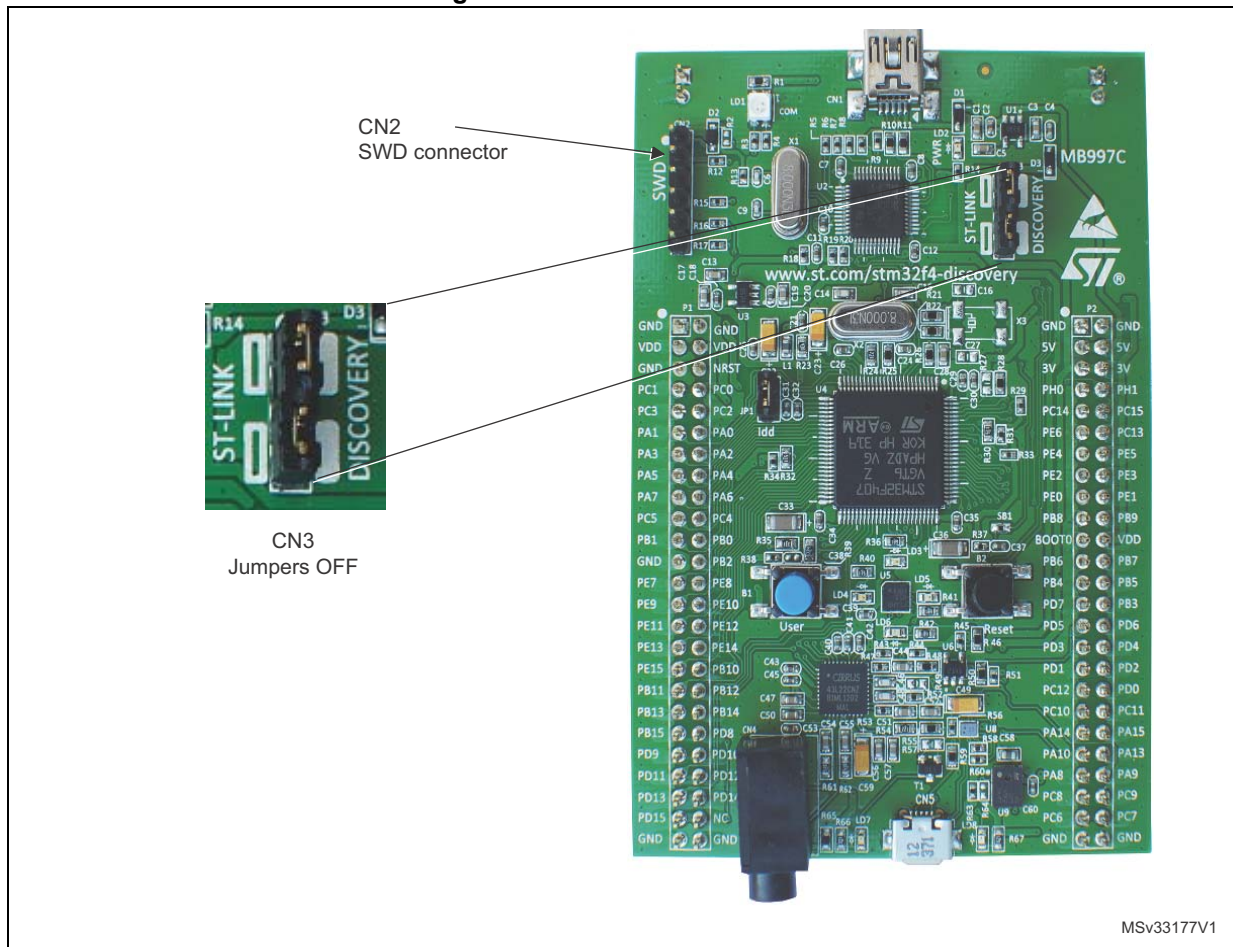

6.2 Power supply and power selection

The power supply is provided either by the host PC through the USB cable, or by an external 5V power supply.

The D1 and D2 diodes protect the 5V and 3V pins from external power supplies:

- 5V and 3V can be used as output power supplies when another application board is connected to pins P1 and P2.
In this case, the 5V and 3V pins deliver a 5V or 3V power supply and power consumption must be lower than 100 mA.
- 5V can also be used as input power supplies e.g. when the USB connector is not connected to the PC.
In this case, the STM32F4DISCOVERY board must be powered by a power supply unit or by auxiliary equipment complying with standard EN-60950-1: 2006+A11/2009, and must be Safety Extra Low Voltage (SELV) with limited power capability.

6.3 LEDs

- LD1 COM: LD1 default status is red. LD1 turns to green to indicate that communications are in progress between the PC and the ST-LINK/V2.
- LD2 PWR: red LED indicates that the board is powered.
- User LD3: orange LED is a user LED connected to the I/O PD13 of the STM32F407VGT6.
- User LD4: green LED is a user LED connected to the I/O PD12 of the STM32F407VGT6.
- User LD5: red LED is a user LED connected to the I/O PD14 of the STM32F407VGT6.
- User LD6: blue LED is a user LED connected to the I/O PD15 of the STM32F407VGT6.
- USB LD7: green LED indicates when VBUS is present on CN5 and is connected to PA9 of the STM32F407VGT6.
- USB LD8: red LED indicates an overcurrent from VBUS of CN5 and is connected to the I/O PD5 of the STM32F407VGT6.

6.4 Push buttons

- B1 USER: User and Wake-Up buttons are connected to the I/O PA0 of the STM32F407VG.
- B2 RESET: Push button connected to NRST is used to RESET the STM32F407VG.

6.5 On-board audio capability

The STM32F407VG microcontroller uses an audio DAC (CS43L22) to output sounds through the audio mini-jack connector.

The STM32F407VG microcontroller controls the audio DAC through the I²C interface and processes digital signals through an I²S connection or an analog input signal.

- The sound can come independently from different inputs:
 - ST-MEMS microphone (MP45DT02): digital using PDM protocol or analog when using the low pass filter
 - USB connector: from external mass storage such as a USB key, USB HDD, and so on
 - Internal memory of the STM32F407VG microcontroller
- The sound can be output in different ways through the audio DAC:
 - Using I²S protocol
 - Using DAC to analog input AIN1x of the CS43L22
 - Using the microphone output directly via a low-pass filter to analog input AIN4x of the CS43L22

6.6 USB OTG supported

The STM32F407VG microcontroller is used on this board to only drive the USB OTG full speed. The USB micro-AB connector (CN5) allows the user to connect a host or device component, such as a USB key, mouse, and so on.

Two LEDs are dedicated to this module:

- LD7 (green LED) indicates when VBUS is active
- LD8 (red LED) indicates an overcurrent from connected device

6.7 Motion sensor (ST-MEMS LIS302DL or LIS3DSH)

Two different versions of motion sensors (U5 in schematic) are available on the board depending on the PCB version. The LIS302DL is present on board MB997B (PCB revision B) and the LIS3DSH is present on board MB997C (PCB rev C).

The LIS302DL and LIS3DSH are both ultra-compact low-power three-axis linear accelerometers.

The motion sensor includes a sensing element and an IC interface able to provide the measured acceleration to the external world through the I²C/SPI serial interfaces.

The LIS302DL has dynamically user selectable full scales of $\pm 2g/\pm 8g$ and it is capable of measuring acceleration with an output rate of 100Hz to 400Hz.

The LIS3DSH has $\pm 2g/\pm 4g/\pm 6g/\pm 8g/\pm 16g$ dynamically selectable full-scale and it is capable of measuring acceleration with an output data rate of 3.125 Hz to 1.6 kHz.

The STM32F407VG microcontroller controls this motion sensor through the SPI interface.

6.8 JP1 (Idd)

Jumper JP1, labeled Idd, allows the consumption of STM32F407VG to be measured by removing the jumper and connecting an ammeter.

- Jumper on: STM32F407VGT6 is powered (default).
- Jumper off: an ammeter must be connected to measure the STM32F407VG current, (if there is no ammeter, the STM32F407VG is not powered).

6.9 OSC clock

6.9.1 OSC clock supply

If PH0 and PH1 are used as GPIOs instead of being used as a clock, then SB13 and SB14 are closed and R24, R25 and R68 are removed.

- **MCO from ST-LINK.** From MCO of the STM32F103. This frequency cannot be changed, it is fixed at 8 MHz and connected to PH0-OSC_IN of the STM32F407VG. Configuration needed:
 - SB13, SB14 OPEN
 - R25^(b) removed
 - R68^(b) soldered
- **Oscillator on board.** From X2 crystal. For typical frequencies and its capacitors and resistors, refer to the STM32F407VG Datasheet at www.st.com. Configuration needed:
 - SB13, SB14 OPEN
 - R25^(b) soldered
 - R68^(b) removed
- **Oscillator from external PH0.** From external oscillator through pin 7 of the P2 connector. Configuration needed:
 - SB13 closed
 - SB14 closed
 - R25 and R68 removed

6.9.2 OSC 32 KHz clock supply

If PC14 and PC15 are only used as GPIOs and not as a clock, then SB15 and SB16 are closed, and R21 and R22 are removed.

- **Oscillator on board.** From X1 crystal (not provided). Configuration needed:
 - SB15, SB16 OPEN
 - C16, C27, R21 and R22 soldered.
- **Oscillator from external PC14.** From external oscillator through the pin 9 of P2 connector. Configuration needed:
 - SB16 closed
 - SB15 closed
 - R21 and R22 removed

b. As the frequency supplied by X2 is the same as MCO (8 MHz), R25 and R68 are soldered.

6.10 Solder bridges

Table 5. Solder bridges

Bridge	State ⁽¹⁾	Description
SB13,14 (X2 crystal) ⁽²⁾	OFF	X2, C14, C15, R24 and R25 provide a clock. PH0, PH1 are disconnected from P2.
	ON	PH0, PH1 are connected to P2 (R24, R25 and R68 must not be fitted).
SB3, 5, 7, 9 (Default)	ON	Reserved, do not modify.
SB2, 4, 6, 8 (Reserved)	OFF	Reserved, do not modify.
SB15,16 (X3 crystal)	OFF	X3, C16, C27, R21 and R22 deliver a 32 KHz clock. PC14, PC15 are not connected to P2.
	ON	PC14, PC15 are only connected to P2. Remove only R21, R22
SB1 (B2-RESET)	ON	B2 pushbutton is connected to the NRST pin of the STM32F407VGT6
	OFF	B2 pushbutton is not connected the NRST pin of the STM32F407VG.
SB20 (B1-USER)	ON	B1 pushbutton is connected to PA0.
	OFF	B1 pushbutton is not connected to PA0.
SB17 (VDD powered from 3V)	OFF	VDD is not powered from 3V, depends on JP1 jumper.
	ON	VDD is permanently powered from 3V, JP1 jumper has no effect.
SB11 (NRST)	ON	NRST signal of the CN2 connector is connected to the NRST pin of the STM32F407VG.
	OFF	NRST signal of the CN2 connector is not connected to the NRST pin of the STM32F407VG.
SB12 (SWO)	ON	SWO signal of the CN2 connector is connected to PB3.
	OFF	SWO signal is not connected.
SB10 (STM_RST)	OFF	No incidence on STM32F103C8T6 (ST-LINK/V2) NRST signal.
	ON	STM32F103C8T6 (ST-LINK/V2) NRST signal is connected to GND.
SB18 (BOOT0)	ON	BOOT0 signal of the STM32F407VG is held low through a 510 ohm pull-down resistor.
	OFF	BOOT0 signal of the STM32F407VG is held high through a 10 Kohm pull-up resistor.
SB19 (BOOT1)	OFF	The BOOT1 signal of the STM32F407VG is held high through a 10 Kohm pull-up resistor.
	ON	The BOOT1 signal of the STM32F407VG is held low through a 510 ohm pull-down resistor.

1. Default SBx state is shown in bold.

2. SB13 and SB14 are OFF to allow the user to choose between MCO and X2 crystal for clock source.

6.11 Extension connectors

The male headers P1 and P2 can connect the STM32F4DISCOVERY to a standard prototyping/wrapping board. STM32F407VG GPIOs are available on these connectors. P1 and P2 can also be probed by an oscilloscope, a logical analyzer or a voltmeter.





Table 6. STM32 pin description versus board functions

STM32 pin			Board function														
Main function	Alternate functions	LQFP 100	CS43 L22	MP45 DT02	LIS302DL or LIS3DSH	Push button	LED	SWD	USB	OSC	Free I/O	Power supply	CN5	CN2	P1	P2	
BOOT0	V _{PP}	94	-	-	-	-	-	-	-	-	-	-	-	-	-	-	21
NRST	-	14	-	-	-	RESET	-	NRST	-	-	-	-	-	5	6	-	-
PA0-WKUP	USART2_CTS/ USART4_TX/ ETH_MII_CRX/ TIM2_CH1_ETR/ TIM5_CH1/ TIM8_ETR/ ADC123_IN0/ WKUP	23	-	-	-	USER	-	-	-	-	PA0 ⁽¹⁾	-	-	-	12	-	-
PA1	USART2_RTS/ USART4_RX/ ETH_RMII_REF_CLK/ ETH_MII_RX_CLK/ TIM5_CH2/ TIMM2_CH2/ ADC123_IN1	24	-	-	-	-	-	-	-	-	PA1	-	-	-	11	-	-
PA2	USART2_TX/ TIM5_CH3/ TIM9_CH1/ TIM2_CH3/ ETH_MDIO/ ADC123_IN2	25	-	-	-	-	-	-	-	-	PA2	-	-	-	14	-	-
PA3	USART2_RX/ TIM5_CH4/ TIM9_CH2/ TIM2_CH4/ OTG_HS_ULPI_D0/ ETH_MII_COL/ ADC123_IN3	26	-	-	-	-	-	-	-	-	PA3	-	-	-	13	-	-
PA4	SPI1_NSS/ SPI3_NSS/ USART2_CK/ DCMI_HSYNC/ OTG_HS_SOF/ I2S3_WS/ ADC12_IN4/ DAC1_OUT	29	LRCK/ AIN1x	-	-	-	-	-	-	-	-	-	-	-	16	-	-
PA5	SPI1_SCK/ OTG_HS_ULPI_CK/ TIM2_CH1_ETR/ TIM8_CH1N/ ADC12_IN5/ DAC2_OUT	30	-	-	SCL/ SPC	-	-	-	-	-	-	-	-	-	15	-	-
PA6	SPI1_MISO/ TIM8_BKIN/ TIM13_CH1/ DCMI_PIXCLK/ TIM3_CH1/ TIM1_BKIN/ ADC12_IN6	31	-	-	SDO	-	-	-	-	-	-	-	-	-	18	-	-
PA7	SPI1_MOSI/ TIM8_CH1N/ TIM14_CH1/TIM3_CH2/ ETH_MII_RX_DV/ TIM1_CH1N/ RMII_CRX_DV/ ADC12_IN7	32	-	-	SDA/SDI /SDO	-	-	-	-	-	-	-	-	-	17	-	-
PA8	MCO1/ USART1_CK/ TIM1_CH1/ I2C3_SCL/ OTG_FS_SOF	67	-	-	-	-	-	-	-	-	PA8	-	-	-	-	-	43
PA9	USART1_TX/ TIM1_CH2/ I2C3_SMBA/ DCMI_D0/ OTG_FS_VBUS	68	-	-	-	-	GREEN	-	V _{BUS}	-	-	-	1	-	-	-	44



Table 6. STM32 pin description versus board functions (continued)

STM32 pin			Board function													
Main function	Alternate functions	LQFP 100	CS43 L22	MP45 DT02	LIS302DL or LIS3DSH	Push button	LED	SWD	USB	OSC	Free I/O	Power supply	CN5	CN2	P1	P2
PA10	USART1_RX/ TIM1_CH3/ OTG_FS_ID/ DCM1_D1	69	-	-	-	-	-	-	ID	-	-	-	4	-	-	41
PA11	USART1_CTS/ CAN1_RX/ TIM1_CH4/ OTG_FS_DM	70	-	-	-	-	-	-	DM	-	-	-	2	-	-	-
PA12	USART1_RTS/ CAN1_TX/ TIM1_ETR/ OTG_FS_DP	71	-	-	-	-	-	-	DP	-	-	-	3	-	-	-
PA13	JTMS-SWDIO	72	-	-	-	-	-	SWDIO	-	-	-	-	-	4	-	42
PA14	JTCK-SWCLK	76	-	-	-	-	-	SWCLK	-	-	-	-	-	2	-	39
PA15	JTDI/ SPI3_NSS/ I2S3_WS/ TIM2_CH1_ETR/ SPI1_NSS	77	-	-	-	-	-	-	-	-	PA15	-	-	-	-	40
PB0	TIM3_CH3/ TIM8_CH2N/ OTG_HS_ULPI_D1/ ETH_MII_RXD2/ TIM1_CH2N/ ADC12_IN8	35	-	-	-	-	-	-	-	-	PB0	-	-	-	22	-
PB1	TIM3_CH4/ TIM8_CH3N/ OTG_HS_ULPI_D2/ ETH_MII_RXD3/ OTG_HS_INTN/ TIM1_CH3N/ ADC12_IN9	36	-	-	-	-	-	-	-	-	PB1	-	-	-	21	-
PB2	BOOT1	37	-	-	-	-	-	-	-	-	-	-	-	-	24	-
PB3	JTDO/ TRACESWO/ SPI3_SCK/ I2S3_CK/ TIM2_CH2/ SPI1_SCK	89	-	-	-	-	-	SWO	-	-	PB3 ⁽¹⁾	-	-	6	-	28
PB4	NJTRST/ SPI3_MISO/ TIM3_CH1/ SPI1_MISO/ I2S3ext_SD	90	-	-	-	-	-	-	-	-	PB4	-	-	-	-	25
PB5	I2C1_SMBA/ CAN2_RX/ OTG_HS_ULPI_D7/ ETH_PPS_OUT/ TIM3_CH2/ SPI1_MOSI/ SPI3_MOSI/ DCMI_D10/ I2S3_SD	91	-	-	-	-	-	-	-	-	PB5	-	-	-	-	26
PB6	I2C1_SCL/ TIM4_CH1/ CAN2_TX/ OTG_FS_INTN/ DCM1_D5/ USART1_TX	92	SCL	-	-	-	-	-	-	-	-	-	-	-	-	23
PB7	I2C1_SDA/ FSMC_NL/ DCMI_VSYNC/ USART1_RX/ TIM4_CH2	93	-	-	-	-	-	-	-	-	PB7	-	-	-	-	24

DocID022256 Rev 6

21/34



Table 6. STM32 pin description versus board functions (continued)

STM32 pin			Board function													
Main function	Alternate functions	LQFP 100	CS43 L22	MP45 DT02	LIS302DL or LIS3DSH	Push button	LED	SWD	USB	OSC	Free I/O	Power supply	CN5	CN2	P1	P2
PB8	TIM4_CH3/ SDIO_D4/ TIM10_CH1/ DCM1_D6/ OTG_FS_SCL/ ETH_MII_TXD3/ I2C1_SCL/ CAN1_RX	95	-	-	-	-	-	-	-	-	PB8	-	-	-	-	19
PB9	SPI2_NSS/ I2S2_WS/ TIM4_CH4/ TIM11_CH1/ OTG_FS_SDA/ SDIO_D5/ DCM1_D7/ I2C1_SDA/ CAN1_TX	96	SDA	-	-	-	-	-	-	-	-	-	-	-	-	20
PB10	SPI2_SCK/ I2S2_CK/ I2C2_SCL/ USART3_TX/ OTG_HS_ULPI_D3/ ETH_MII_RX_ER/ OTG_HS_SCL/ TIM2_CH3	47	-	CLK	-	-	-	-	-	-	-	-	-	-	34	-
PB11	I2C2_SDA/ USART3_RX/ OTG_HS_ULPI_D4/ ETH_RMII_TX_EN/ ETH_MII_TX_EN/ OTG_HS_SDA/ TIM2_CH4	48	-	-	-	-	-	-	-	-	PB11	-	-	-	35	-
PB12	SPI2_NSS/ I2S2_WS/ I2C2_SMBA/ USART3_CK/ TIM1_BKIN/ CAN2_RX/ OTG_HS_ULPI_D5/ ETH_RMII_TXD0/ ETH_MII_TXD0/ OTG_HS_ID	51	-	-	-	-	-	-	-	-	PB12	-	-	-	36	-
PB13	SPI2_SCK/ I2S2_CK/ USART3_CTS/ TIM1_CH1N/ CAN2_TX/ OTG_HS_ULPI_D6/ ETH_RMII_TXD1/ ETH_MII_TXD1/ OTG_HS_VBUS	52	-	-	-	-	-	-	-	-	PB13	-	-	-	37	-
PB14	SPI2_MISO/ TIM1_CH2N/ TIM12_CH1/ OTG_HS_DMUSART3_RTS/ TIM8_CH2N/ I2S2ext_SD	53	-	-	-	-	-	-	-	-	PB14	-	-	-	38	-
PB15	SPI2_MOSI/ I2S2_SD/ TIM1_CH3N/ TIM8_CH3N/ TIM12_CH2/ OTG_HS_DP	54	-	-	-	-	-	-	-	-	PB15	-	-	-	39	-
PC0	OTG_HS_ULPI_STP/ ADC123_IN10	15	-	-	-	-	-	-	Power On	-	-	-	-	-	8	-
PC1	ETH_MDC/ ADC123_IN11	16	-	-	-	-	-	-	-	-	PC1	-	-	-	7	-
PC2	SPI2_MISO/ OTG_HS_ULPI_DIR/ ETH_MII_TXD2/ I2S2ext_SD/ ADC123_IN12	17	-	-	-	-	-	-	-	-	PC2	-	-	-	10	-



Table 6. STM32 pin description versus board functions (continued)

STM32 pin			Board function													
Main function	Alternate functions	LQFP 100	CS43 L22	MP45 DT02	LIS302DL or LIS3DSH	Push button	LED	SWD	USB	OSC	Free I/O	Power supply	CN5	CN2	P1	P2
PC3	SPI2_MOSI/ I2S2_SD/ OTG_HS_ULPI_NXT/ ETH_MII_TX_CLK/ ADC123_IN13	18	-	DOUT/A IN4x	-	-	-	-	-	-	-	-	-	-	9	-
PC4	ETH_RMII_RX_D0/ ETH_MII_RX_D0/ ADC12_IN14	33	-	-	-	-	-	-	-	-	PC4	-	-	-	20	-
PC5	ETH_RMII_RX_D1/ ETH_MII_RX_D1/ ADC12_IN15	34	-	-	-	-	-	-	-	-	PC5	-	-	-	19	-
PC6	I2S2_MCK/ TIM8_CH1/ SDIO_D6/ USART6_TX/ DCMI_D0/ TIM3_CH1	63	-	-	-	-	-	-	-	-	PC6	-	-	-	-	47
PC7	I2S3_MCK/ TIM8_CH2/ SDIO_D7/ USART6_RX/ DCMI_D1/ TIM3_CH2	64	MCLK	-	-	-	-	-	-	-	-	-	-	-	-	48
PC8	TIM8_CH3/ SDIO_D0/ TIM3_CH3/ USART6_CK/ DCMI_D2	65	-	-	-	-	-	-	-	-	PC8	-	-	-	-	45
PC9	I2S_CKIN/ MCO2/ TIM8_CH4/ SDIO_D1/ I2C3_SDA/ DCMI_D3/ TIM3_CH4	66	-	-	-	-	-	-	-	-	PC9	-	-	-	-	46
PC10	SPI3_SCK/ I2S3_CK/ UART4_TX/ SDIO_D2/ DCMI_D8/ USART3_TX	78	SCLK	-	-	-	-	-	-	-	-	-	-	-	-	37
PC11	UART4_RX/ SPI3_MISO/ SDIO_D3/ DCMI_D4/ USART3_RX/ I2S3ext_SD	79	-	-	-	-	-	-	-	-	PC11	-	-	-	-	38
PC12	UART5_TX/ SDIO_CK/ DCMI_D9/ SPI3_MOSI/ I2S3_SD/ USART3_CK	80	SDIN	-	-	-	-	-	-	-	-	-	-	-	-	35
PC13	RTC_AF1	7	-	-	-	-	-	-	-	-	PC13	-	-	-	-	12
PC14	OSC32_IN	8	-	-	-	-	-	-	-	OSC32_IN	PC14 ⁽¹⁾	-	-	-	-	9
PC15	OSC32_OUT	9	-	-	-	-	-	-	-	OSC32_OUT	PC15 ⁽¹⁾	-	-	-	-	10
PD0	FSMC_D2/ CAN1_RX	81	-	-	-	-	-	-	-	-	PD0	-	-	-	-	36
PD1	FSMC_D3/ CAN1_TX	82	-	-	-	-	-	-	-	-	PD1	-	-	-	-	33
PD2	TIM3_ETR/ UART5_RXSDIO_CMD / DCMI_D11	83	-	-	-	-	-	-	-	-	PD2	-	-	-	-	34
PD3	FSMC_CLK/ USART2_CTS	84	-	-	-	-	-	-	-	-	PD3	-	-	-	-	31
PD4	FSMC_NOE/ USART2_RTS	85	RESET	-	-	-	-	-	-	-	-	-	-	-	-	32

DocID022256 Rev 6

23/34

UM1472

Hardware and layout



Table 6. STM32 pin description versus board functions (continued)

STM32 pin			Board function													
Main function	Alternate functions	LQFP 100	CS43 L22	MP45 DT02	LIS302DL or LIS3DSH	Push button	LED	SWD	USB	OSC	Free I/O	Power supply	CN5	CN2	P1	P2
PD5	FSMC_NWE/ USART2_TX	86	-	-	-	-	RED	-	Over current	-	-	-	-	-	-	29
PD6	FSMC_NWAIT/ USART2_RX	87	-	-	-	-	-	-	-	-	PD6	-	-	-	-	30
PD7	USART2_CK/ FSMC_NE1/ FSMC_NCE2	88	-	-	-	-	-	-	-	-	PD7	-	-	-	-	27
PD8	FSMC_D13/ USART3_TX	55	-	-	-	-	-	-	-	-	PD8	-	-	-	40	-
PD9	FSMC_D14/ USART3_RX	56	-	-	-	-	-	-	-	-	PD9	-	-	-	41	-
PD10	FSMC_D15/ USART3_CK	57	-	-	-	-	-	-	-	-	PD10	-	-	-	42	-
PD11	FSMC_A16/ USART3_CTS	58	-	-	-	-	-	-	-	-	PD11	-	-	-	43	-
PD12	FSMC_A17/ TIM4_CH1/ USART3_RTS	59	-	-	-	-	GREEN	-	-	-	-	-	-	-	44	-
PD13	FSMC_A18/ TIM4_CH2	60	-	-	-	-	ORANGE	-	-	-	-	-	-	-	45	-
PD14	FSMC_D0/ TIM4_CH3	61	-	-	-	-	RED	-	-	-	-	-	-	-	46	-
PD15	FSMC_D1/ TIM4_CH4	62	-	-	-	-	BLUE	-	-	-	-	-	-	-	47	-
PE0	TIM4_ETR/ FSMC_NBL0/ DCMI_D2	97	-	-	INT1	-	-	-	-	-	-	-	-	-	-	17
PE1	FSMC_NBL1/ DCMI_D3	98	-	-	INT2	-	-	-	-	-	-	-	-	-	-	18
PE2	TRACECLK/ FSMC_A23/ ETH_MII_TXD3	1	-	-	-	-	-	-	-	-	PE2	-	-	-	-	15
PE3	TRACED0/ FSMC_A19	2	-	-	CS_I2C/SPI	-	-	-	-	-	-	-	-	-	-	16
PE4	TRACED1/ FSMC_A20/ DCMI_D4	3	-	-	-	-	-	-	-	-	PE4	-	-	-	-	13
PE5	TRACED2/ FSMC_A21/ TIM9_CH1/ DCMI_D6	4	-	-	-	-	-	-	-	-	PE5	-	-	-	-	14
PE6	TRACED3/ FSMC_A22/ TIM9_CH2/ DCMI_D7	5	-	-	-	-	-	-	-	-	PE6	-	-	-	-	11
PE7	FSMC_D4/ TIM1_ETR	38	-	-	-	-	-	-	-	-	PE7	-	-	-	25	-
PE8	FSMC_D5/ TIM1_CH1N	39	-	-	-	-	-	-	-	-	PE8	-	-	-	26	-
PE9	FSMC_D6/ TIM1_CH1	40	-	-	-	-	-	-	-	-	PE9	-	-	-	27	-
PE10	FSMC_D7/ TIM1_CH2N	41	-	-	-	-	-	-	-	-	PE10	-	-	-	28	-
PE11	FSMC_D8/ TIM1_CH2	42	-	-	-	-	-	-	-	-	PE11	-	-	-	29	-

Table 6. STM32 pin description versus board functions (continued)

STM32 pin			Board function													
Main function	Alternate functions	LQFP 100	CS43 L22	MP45 DT02	LIS302DL or LIS3DSH	Push button	LED	SWD	USB	OSC	Free I/O	Power supply	CN5	CN2	P1	P2
PE12	FSMC_D9/ TIM1_CH3N	43	-	-	-	-	-	-	-	-	PE12	-	-	-	30	-
PE13	FSMC_D10/ TIM1_CH3	44	-	-	-	-	-	-	-	-	PE13	-	-	-	31	-
PE14	FSMC_D11/ TIM1_CH4	45	-	-	-	-	-	-	-	-	PE14	-	-	-	32	-
PE15	FSMC_D12/ TIM1_BKIN	46	-	-	-	-	-	-	-	-	PE15	-	-	-	33	-
PH0	OSC_IN	12	-	-	-	-	-	-	-	OSC_IN	PH0 ⁽¹⁾	-	-	-	-	7
PH1	OSC_OUT	13	-	-	-	-	-	-	-	OSC_OUT	PH1 ⁽¹⁾	-	-	-	-	8
-	-	-	-	-	-	-	-	-	-	-	-	5V	-	-	-	3
-	-	-	-	-	-	-	-	-	-	-	-	5V	-	-	-	4
-	-	-	-	-	-	-	-	-	-	-	-	3V	-	-	-	5
-	-	-	-	-	-	-	-	-	-	-	-	3V	-	-	-	6
-	-	-	-	-	-	-	-	-	-	-	-	VDD	-	-	3	-
-	-	-	-	-	-	-	-	-	-	-	-	VDD	-	-	4	-
-	-	-	-	-	-	-	-	-	-	-	-	VDD	-	-	-	22
-	-	-	-	-	-	-	-	-	GND	GND	-	GND	5	3	1	-
-	-	-	-	-	-	-	-	-	-	-	-	GND	-	-	2	-
-	-	-	-	-	-	-	-	-	-	-	-	GND	-	-	5	-
-	-	-	-	-	-	-	-	-	-	-	-	GND	-	-	23	-
-	-	-	-	-	-	-	-	-	-	-	-	GND	-	-	49	-
-	-	-	-	-	-	-	-	-	-	-	-	GND	-	-	50	-
-	-	-	-	-	-	-	-	-	-	-	-	GND	-	-	-	1
-	-	-	-	-	-	-	-	-	-	-	-	GND	-	-	-	2
-	-	-	-	-	-	-	-	-	-	-	-	GND	-	-	-	49
-	-	-	-	-	-	-	-	-	-	-	-	GND	-	-	-	50

1. Optional, for more details see [Section 7: Electrical schematics](#).

Figure 10. ST-LINK/V2 (SWD only)

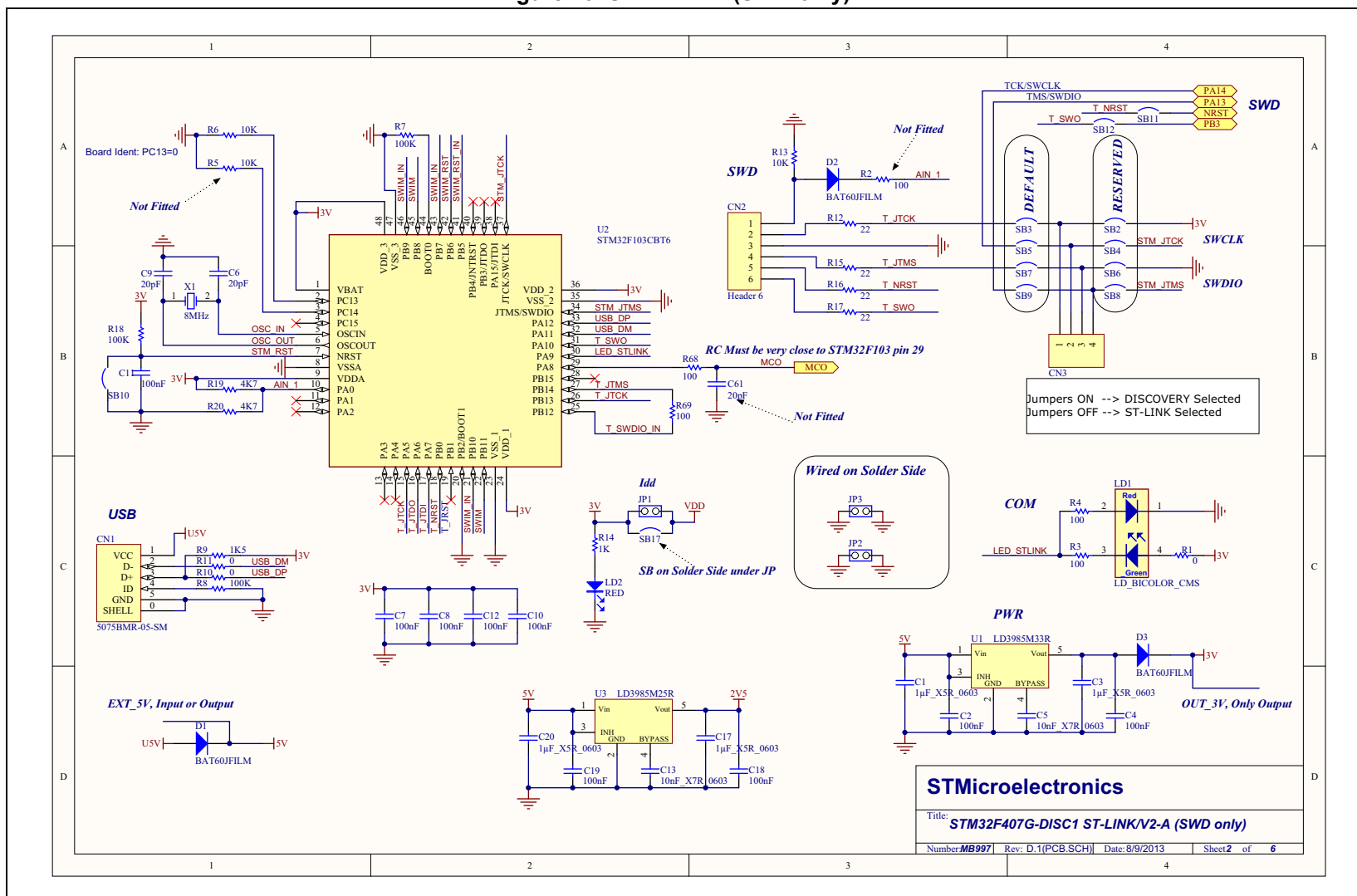



Figure 11. MCU

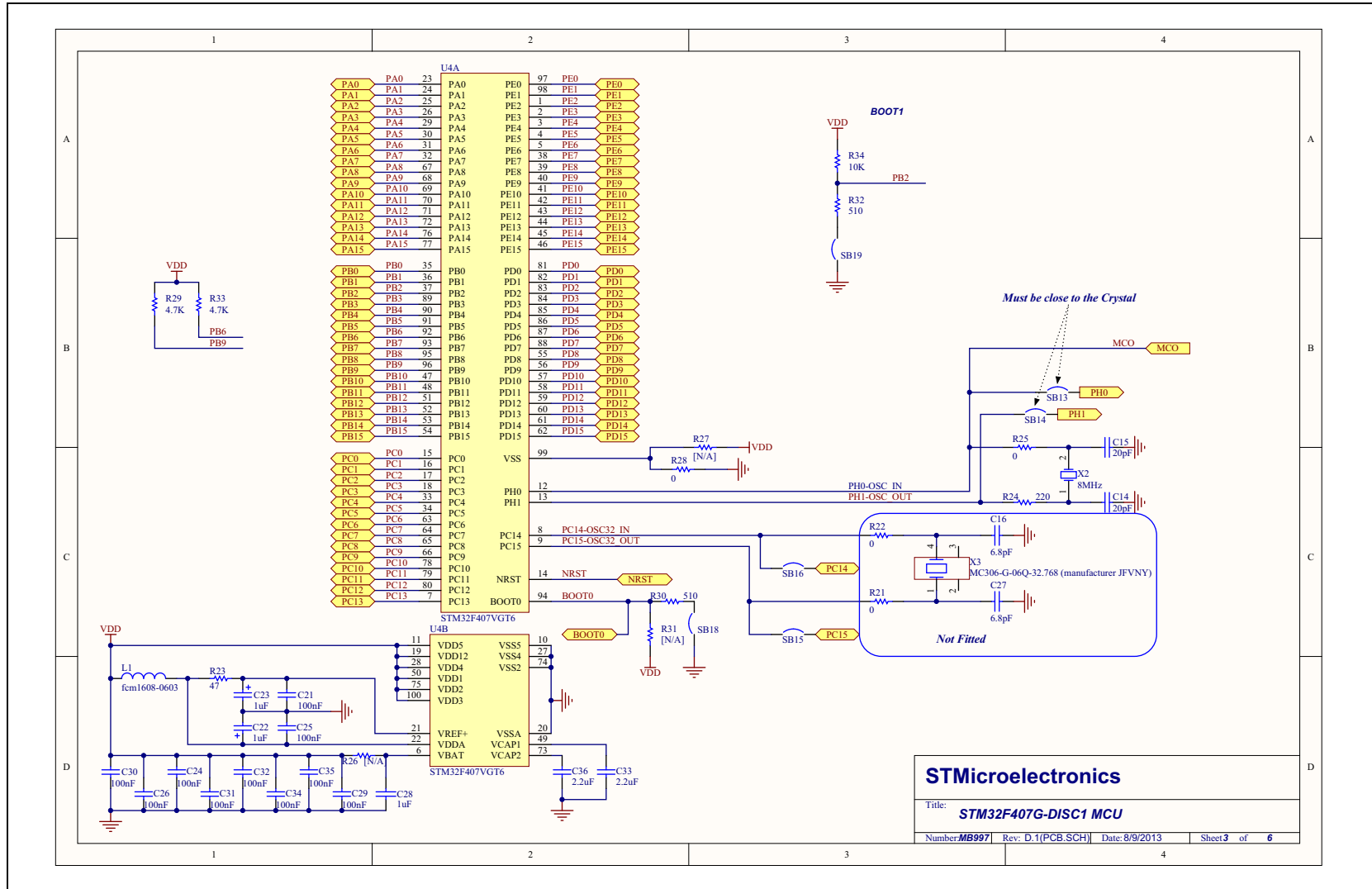

Figure 12. Audio

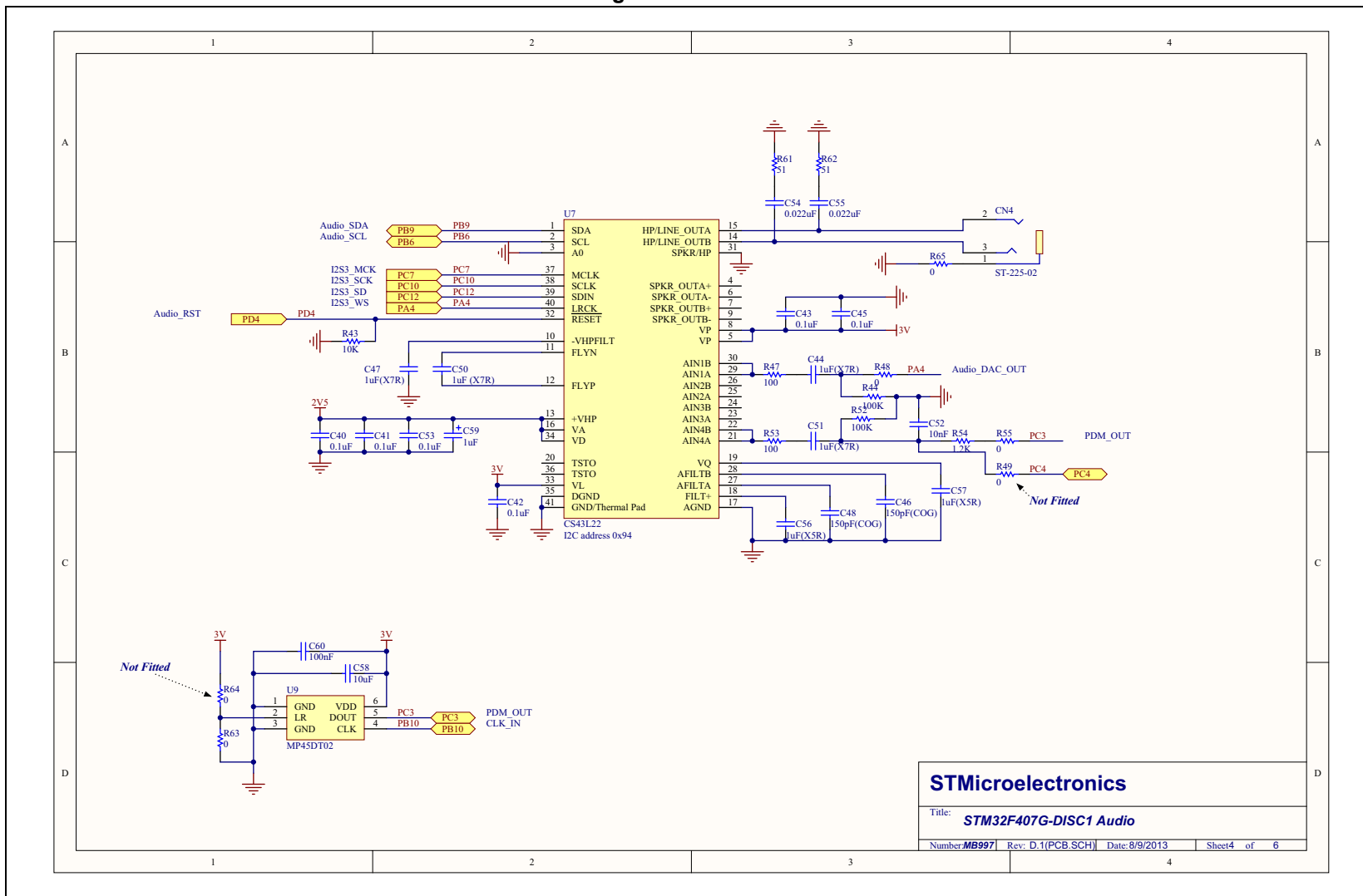



Figure 13. USB_OTG_FS

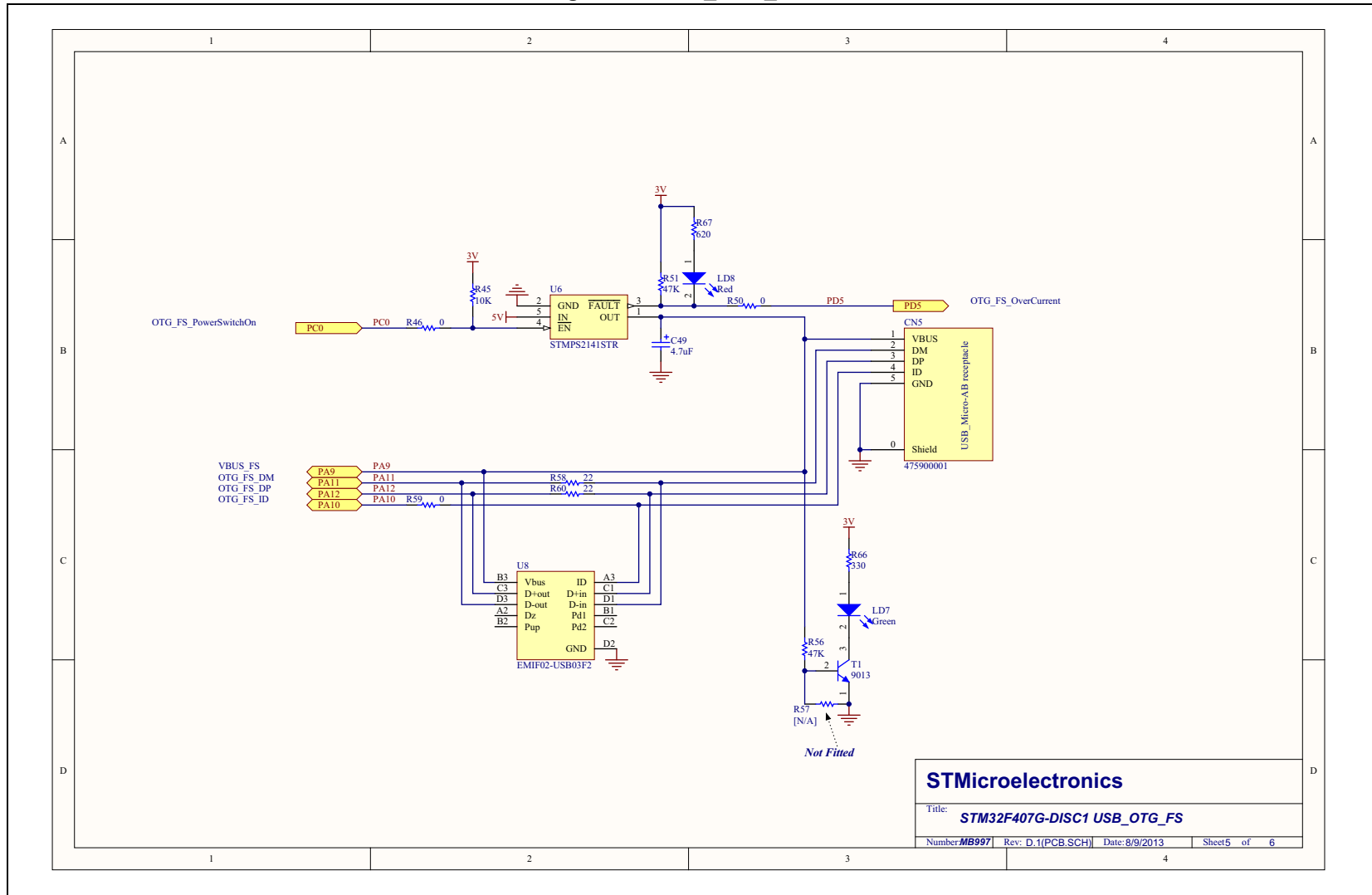
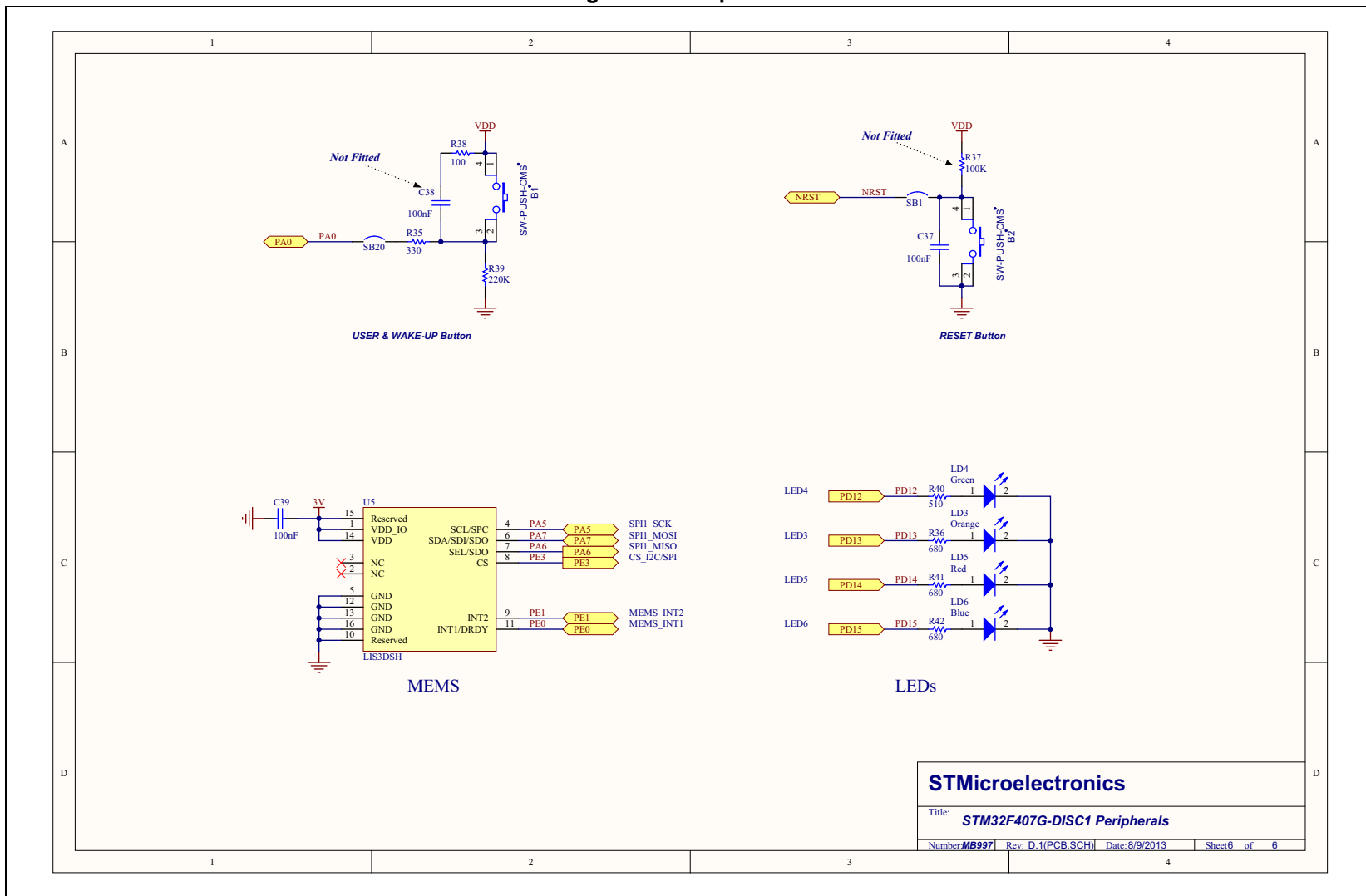
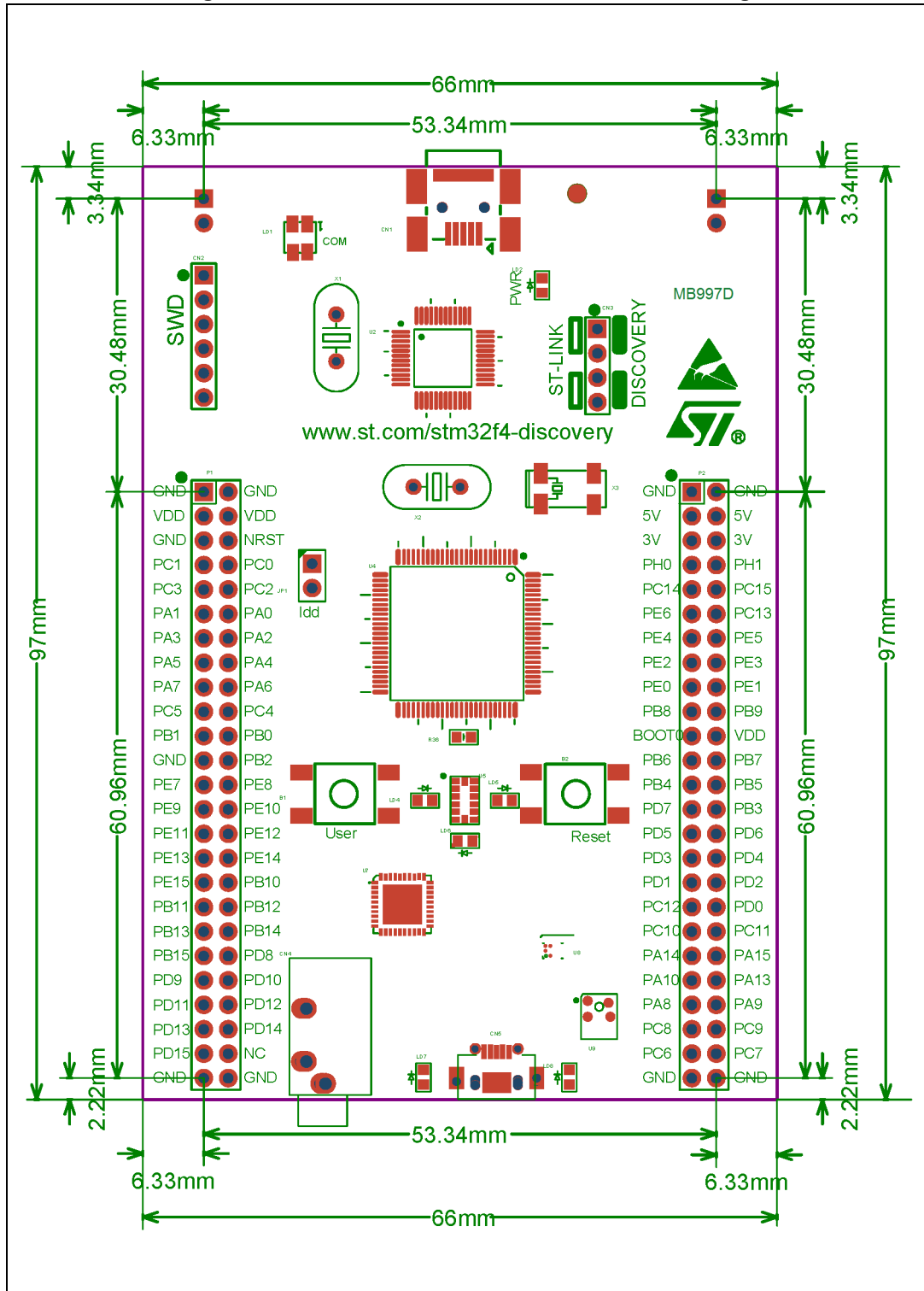

Figure 14. Peripherals



8 Mechanical drawing

Figure 15. STM32F4DISCOVERY mechanical drawing



9 Revision history

Table 7. Document revision history

Date	Revision	Changes
27-Sept-2011	1	Initial release.
30-Jan-2012	2	Added Section 5.1: STM32F407VGT6 microcontroller corrected Figure 3 MCU name, modified Figure 2 and Section 7: Electrical schematics . Modified Table 6 PE2 and PE3 entries.
28-Nov-2013	3	Updated for board rev. C. Modified title. Modified Section 6.7: Motion sensor (ST-MEMS LIS302DL or LIS3DSH) Updated Section 7: Electrical schematics
29-Jan-2014	4	Modified Section 6: Hardware and layout , Figure 2 , Section 6.7: Motion sensor (ST-MEMS LIS302DL or LIS3DSH) , Table 6 adding ST MEMS LIS302DL reference.
04-Feb-2016	5	New revision to introduce STM32F407G-DISC1 additional CPN that corresponds to mbed-enabled Discovery Kit. Updated Introduction , Features , Section 5: Quick start , Section 6: Hardware and layout , Section 6.1: Embedded ST-LINK/V2 (or V2-A) , Section 7: Electrical schematics . Removed Section 4.1 STM32F407VG microcontroller.
31-May-2017	6	Updated Table 6: STM32 pin description versus board functions .

IMPORTANT NOTICE – PLEASE READ CAREFULLY

STMicroelectronics NV and its subsidiaries ("ST") reserve the right to make changes, corrections, enhancements, modifications, and improvements to ST products and/or to this document at any time without notice. Purchasers should obtain the latest relevant information on ST products before placing orders. ST products are sold pursuant to ST's terms and conditions of sale in place at the time of order acknowledgement.

Purchasers are solely responsible for the choice, selection, and use of ST products and ST assumes no liability for application assistance or the design of Purchasers' products.

No license, express or implied, to any intellectual property right is granted by ST herein.

Resale of ST products with provisions different from the information set forth herein shall void any warranty granted by ST for such product.

ST and the ST logo are trademarks of ST. All other product or service names are the property of their respective owners.

Information in this document supersedes and replaces information previously supplied in any prior versions of this document.

© 2017 STMicroelectronics – All rights reserved

单击下面可查看定价，库存，交付和生命周期等信息

[>>STMicroelectronics\(意法半导体\)](#)