

Approval Request

TO:

MODEL NAME: Ceramic Resonator

PART NO: ZTTCC2.00MG

CUSTOMER PART NO.: CSTCC2M00G56-RO

Approved	Yes
Customer's comments are welcomed here.	No.
Pls return this copy as a certificate of your approval. By Date: / /	

STRONG ELECTRONICS&TECHNOLOGY LIMITED

Tel:86-755-84528985 Fax: 86-755-84528986

Email:info@strongelectronics.net

www.strongelectronics.net

CERAMIC RESONATOR SPECIFICATION

1. SCOPE

This specification shall cover the characteristics of the ceramic resonator with 3.58MHz used in oscillate circuit.

2. PART NO: ZTTCC2.00MG

3. ELECTRICAL SPECIFICATION

No	Item	Requirements
3.1	Oscillation Frequency (Fosc)	2.00MHz \pm 0.5%
3.2	Resonant Impedance (Ro)	80 Ω max
3.3	Temperature Coefficient of Oscillation Frequency	\pm 0.3% max (-40°C to +85°C)
3.4	Withstanding Voltage	100 VDC 5 sec.max
3.5	Rating Voltage (1) D.C. Voltage (2) A.C. Voltage	6 V.D.C. 15 Vpp.
3.6	Insulation Resistance	100M Ω min. (at 10 VDC)
3.7	Operating Temperature	-40°C to +85°C
3.8	Storage Temperature	-55°C to +85°C
3.9	Aging Rate (Fosc)	\pm 0.3% max (10 year)

4. MEASUREMENT

4.1 Measurement Condition

The reference temperature shall be 25°C \pm 2°C. The measurement shall be performed at the temperature range of 5°C to 35°C unless otherwise the result is doubtful.

4.2 Measurement Circuit and Equipment

Oscillating frequency shall be measured by the standard test circuit as shown in Fig.1

Resonant impedance shall be measured by HP5100A Network Analyzer.

4.3 TEST CIRCUIT

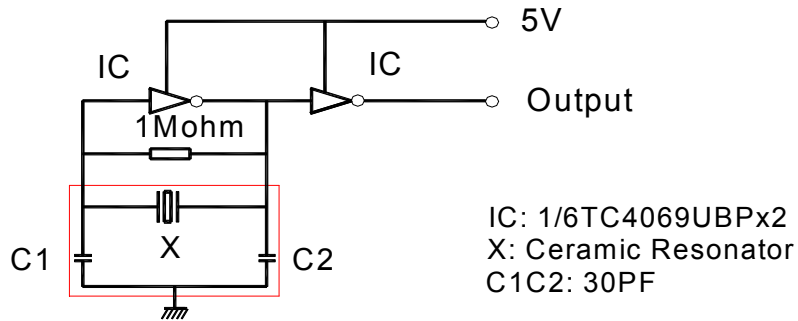

5. DIMENSIONS

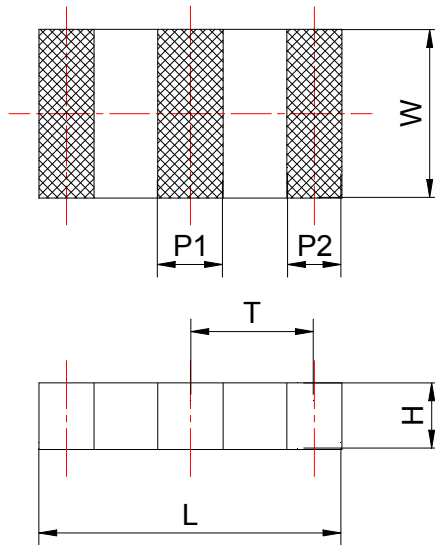

P/N	Dimension (mm)					
	L	W	H	P1	P2	T
ZTTCCMG	7.4±0.3	3.4±0.3	1.8±0.3	1.2±0.3	1.2±0.3	2.5±0.3

6. PHYSICAL AND ENVIRONMENTAL CHARACTERISTICS

No	Item	Condition of Test	Performance Requirements
6.1	Humidity	Keep the resonator at $40 \pm 2^\circ\text{C}$ and 90-95% RH for 96 ± 4 hours. Then release the resonator into the room condition for 1 hour prior to the measurement.	It shall fulfill the specifications in Table 1.
6.2	Vibration	Subject the resonator to vibration for 2 hours each in x,y and z axis with the amplitude of 1.5mm, the frequency shall be varied uniformly between the limits of 10—55Hz	It shall fulfill the specifications in Table 1.
6.3	Mechanical Shock	Drop the resonator randomly onto a concrete floor from the height of 100 cm 3 times.	It shall fulfill the specifications in Table 1.
6.4	Resistance to Solder Heat	Dip the resonator terminals no closer than 2 mm into the solder bath $260 \pm 5^\circ\text{C}$ for 10 ± 1 sec., then release it into the room condition for 1 hour prior to the measurement.	It shall fulfill the specifications in Table 1.
6.5	Solderability	Dip the resonator terminals no closer than 2 mm into the solder bath at $230 \pm 5^\circ\text{C}$ for 3 ± 0.5 sec.	More than 95% of the terminal surface of the resonator shall be covered with fresh solder.
6.6	High Temperature Exposure	Subject the resonator to $80 \pm 5^\circ\text{C}$ for 96 ± 4 hours. Then release the resonator into the room conditions for 1 hour prior to the measurement.	It shall fulfill the specifications in Table 1.
6.7	Low Temperature	Subject the resonator to $-20 \pm 5^\circ\text{C}$ for 96 ± 4 hours. Then release the resonator into the room conditions for 1 hour prior to the measurement.	It shall fulfill the specifications in Table 1.
6.8	Temperature Cycling	Subject the resonator to -20°C for 30 min. followed by a high temperature of 85°C for 30 min. Cycling shall be repeated 5 times with a transfer time of 15 sec. at the room condition. Then release the resonator into the room temperature for 1 hour prior to the measurement.	It shall fulfill the specifications in Table 1.

6. PHYSICAL AND ENVIRONMENTAL CHARACTERISTICS
(Continued from the preceding page)

No	Item	Condition of Test	Performance Requirements
6.9	Lead Fatigue (1) Pulling Test	Weight along with the direction of terminals without any shock 0.5 kg for 10 ± 1 sec.	The resonator shall show no evidence of damage and shall fulfill all the initial electric characteristics.
	(2) Bending Test	Lead shall be subject to withstand against 90 degree bending at its stem. This operation shall be done towards both direction.	

TABLE1

Item	Specification
Oscillation Frequency Change	$\Delta F/F_{osc} \leq 0.5\% \text{ max}$
Resonant Impedance	$\Delta R_o \leq 5 \Omega$

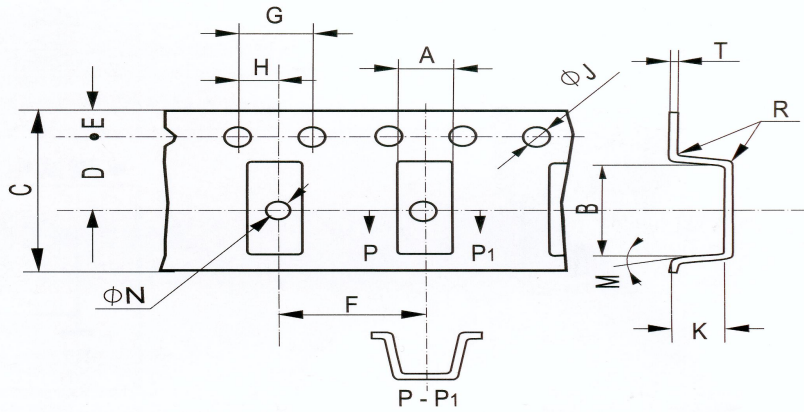

Tape Dimension (mm)

	A ± 0.2	B ± 0.2	C ± 0.3	D ± 0.1	E ± 0.1	F ± 0.1	G ± 0.1	H ± 0.1	ØJ ± 0.1	ØN ± 0.1	M max	R max	K ± 0.2	T ± 0.1
MG	3.8	7.8	16.0	7.5	1.75	8.0	4.0	2.0	1.5	1.6	10°	0.3	2.1	0.3
MT	5.0	4.4	12.0	5.5									1.8	
MX	3.4	4.0	12.0	5.5									1.3	

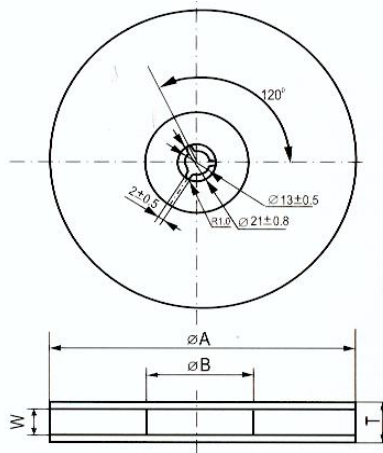

ØA	ØB	W	T	Pieces per reel	Carrier tape size
179±2	60 typ	12.4min	19.4max	1000typ.	12
179±2	60 typ	16.4min	22.4max	1000typ.	16
330±3	80 min	12.4min	19.4max	4000typ.	12
330±3	80 min	16.4min	22.4max	4000typ.	16

单击下面可查看定价，库存，交付和生命周期等信息

[>>StrongFirst\(思硕\)](#)