

HRK	DATE	REMARKS
Δ		
Δ		

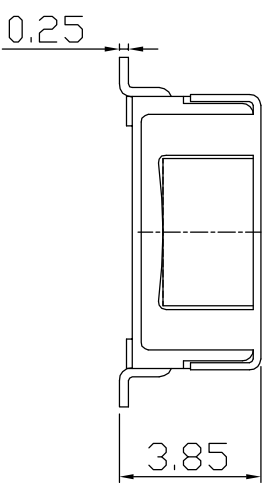
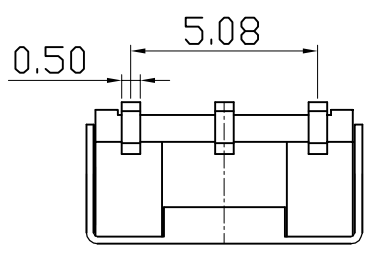
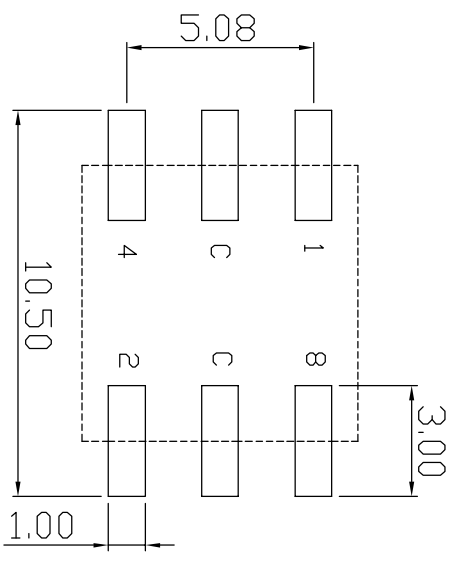
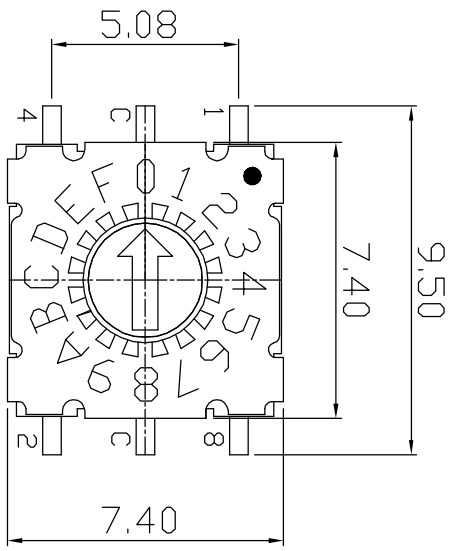

### SPECIFICATION

1. Operating Voltage : 42v  
(None-Switching: 400mA)  
(Switching : 100mA)
2. Contact Resistance : 80mΩ Max
3. Insulation Resistance : 100MΩ Min
4. Operating Force : 120gf ±30gf Max
5. Life cycle : 25,000 steps

		Real Coded				
		C	1	2	4	8
0	●					
1	●	●				
2	●		●			
3	●			●		
4	●				●	
5	●					●
6	●				●	
7	●					●
8	●					
9	●					
A	●					
B	●					
C	●					
D	●					
E	●					
F	●					

APPD	CHKD	D'SGD	TITLE
K.L LEE	J.P ROH	H.S LEE	MINI ROTARY DIP SWITCH
MODEL NO.			MADR-16S
SUNGMUN ELECTRONICS CO., LTD.			REV A



# MINI ROTARY DIP SWITCH SPECIFICATION

Rev. 7  
P:1/4

**1. Style:**

This specification describes "Rotary Switch" mainly used as signal switch of electric devices with the general requirements of mechanical and electrical characteristics.

1.1 Operating / Storage Temperature Range : -60°C ~ +125°C

**2. Current Range:**

2.1 None-Switching : 400 mA, 42V

2.2 Switching : 100 mA, 42V

3. Type of Actuation : Rotating

4. Test Sequence :

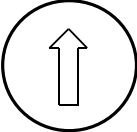
	ITEM	DESCRIPTION	TEST CONDITIONS	REQUIREMENTS
ELECTRIC PERFORMANCE	1	Visual Examination	By visual examination check without any out pressure & testing.	There shall be no defects that affect the serviceability of the product
	2	Contact Resistance	① To be measured between the two terminals associated with each switch pole ② Measurements shall be made with a 1kHz shall current contact resistance meter	80mΩ max.(initial)
	3	Insulation Resistance	250V DC, 1minute ±5seconds	100MΩ min
	4	Dielectric withstanding Volotage	250V AC(50Hz or 60Hz)shall be applied between all the adjacent terminal and between the terminal and the frame For 1 minute	There shall be no breakdown or flashover
MACHIN	5	Operation Force	Applied in the direction of operation 	120gf ±30gf



# MINI ROTARY DIP SWITCH SPECIFICATION

Rev. 7  
P: 2/4

<b>P E R F O R M A N C E</b>	6	Operation Life	<p>Measurements shall be made following the test set forth below:</p> <p>1)100mA, 42V DC resistive load 2)Rate of operation: 15~20 cycles/ minute 3)Step of operation: 25,000 steps</p>	<p>1)As shown in item 3,4 2)Contact Resistance: 200mΩ max 3)Final-after test</p>	
	<b>W E A T H E R  P R O O F</b>	7	Resistance Low Temperature	<p>Following the test set forth below the sample shall be left in normal temperature and humidity conditions for an hour before measurements are made:</p> <p>1)Temperature: -60℃ ±3℃ 2)Time: 96 hours</p>	As shown in item 2~5
		8	Resistance High Temperature	<p>Following the test set forth below the sample shall be left in normal temperature and humidity conditions for an hour before measurements are made:</p> <p>1)Temperature: 125℃ ±2℃ 2)Time: 96 hours</p>	<p>1)As shown in item 3~5 2)Contact Resistance: 200mΩ max</p>
9		Resistance Humidity	<p>Following the test set forth below the sample shall be left in normal temperature and humidity conditions for an hour before measurements are made:</p> <p>1)Temperature: 40℃ ±2℃ 2)Relative humidity: 90~95% 3)Time: 96 hours</p>	<p>1)As shown in item 4 2)Contact Resistance: 200mΩ max 3)Insulation Resistance: 10MΩ min</p>	

SUNGMUN ELECTRONICS CO., LTD.



# MINI ROTARY DIP SWITCH SPECIFICATION

Rev. 7  
P: 3/4

## 5. Reflow Soldering Conditions:

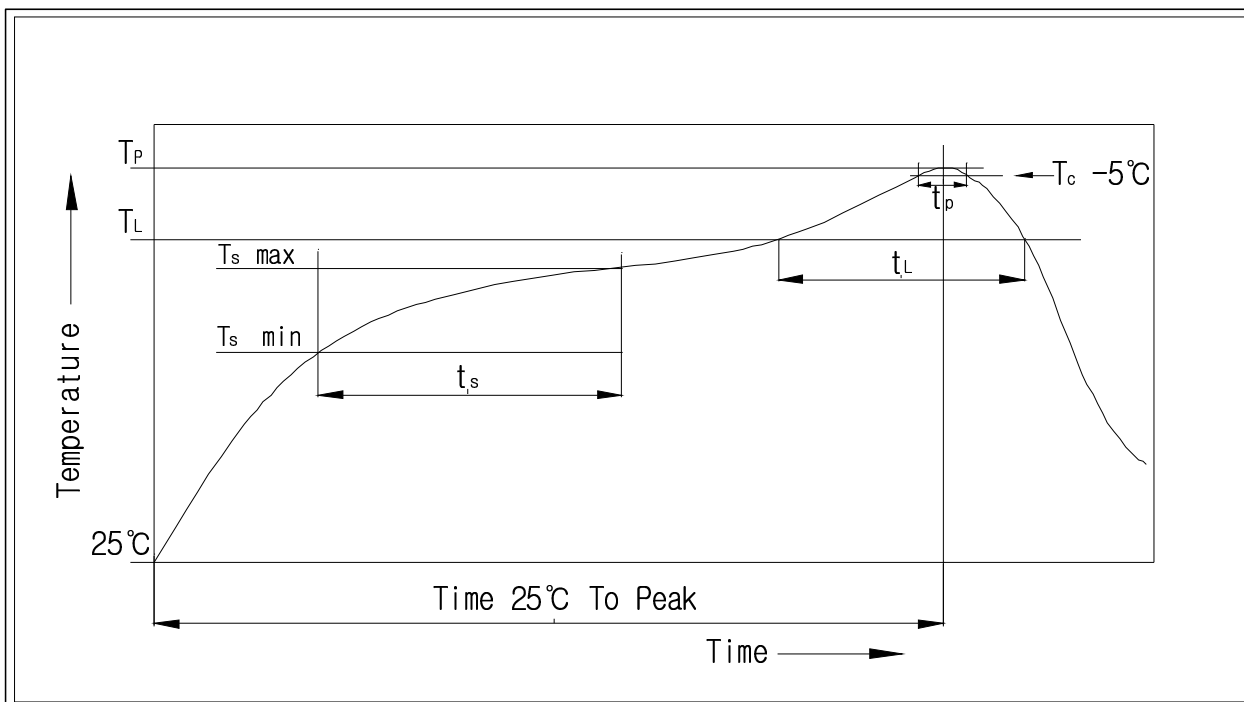

### 1) Classification Reflow Profiles

Profile Feature	Pb-Free Assembly
Average Ramp-UP Rate( $T_s$ max to $T_p$ )	3°C/second max
<b>Preheat</b> - Temperature Min( $T_s$ min) - Temperature Max( $T_s$ max) - Time ( $t_s$ min to $t_s$ max)	150°C 200°C 60-180seconds
Time maintained above: - Temperature ( $T_L$ ) - Time ( $t_L$ )	217°C 60-150seconds
Peak/Classification Temperature( $T_p$ )	260°C +0°C/ -5°C
Time within 5°C of actual Peak Temperature( $T_p$ )	min 30 seconds
<b>Ramp-Down Rate</b>	6°C/sec max
<b>Time 25°C to Peak Temperature</b>	<b>8 minutes max</b>

6. This item is "ROHS" Compliant

SUNGMUN ELECTRONICS CO., LTD.



# MINI ROTARY DIP SWITCH SPECIFICATION

Rev. 7  
P: 4/4

## 7. Part List

NO	Part Name	Q'ty	Materials	Treatment	Remark
1	Cover	1	Stainless Steel		
2	Spring Plate	1	Stainless Steel		
3	Guide Plate	1	Stainless Steel		
4	Contact	1	Phosphor Bronze	Plating: Gold	Au 0.07 $\mu$ m Min Ni 0.1 $\mu$ m Min
5	Terminal	1	Phosphor Bronze	Plating: Gold	Au 0.07 $\mu$ m Min Ni 0.3 $\mu$ m Min
6	Rotor	1	LCP		
7	Base	1	LCP		
8	O-Ring	1	Silicone		

SUNGMUN ELECTRONICS CO., LTD.

单击下面可查看定价，库存，交付和生命周期等信息

[>>SUNGMUN\(韩国星纹电子\)](#)