

# MINI SLIDE SWITCH

**NEW**

**NSI-20**  
Series



## General Specification

1. **Rating :** DC 12V 0.5A~24V 0.3A
2. **Contact Resistance :** 30mΩ Max.
3. **Insulation Resistance :** Min 10,000 MΩ at DC 500V
4. **Operating Force :** 250gf ±150gf
5. **Travel :** 1.6mm
6. **Life Cycle :** 2,000 cycle(with load)

## HOW TO ORDER

**NSI**

**Type**

NSI Through-Hole Type / SMD Type

—

**20**

**Circuit**

20 Switching Type



**Terminal**

- Straight Type
- H Angle Type
- S SMD Type of Vertical
- HS SMD Type of Angle

## MODULAR BUILDING BLOCK

Mini Slide Switch Modules can be mounted side by side

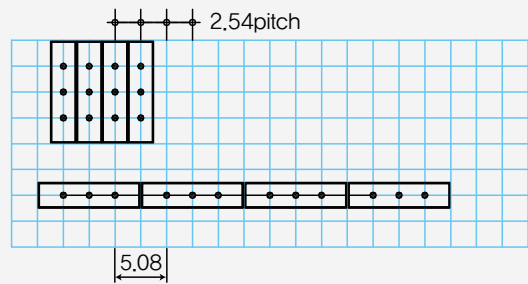

### NSI-20 Type (Switching)

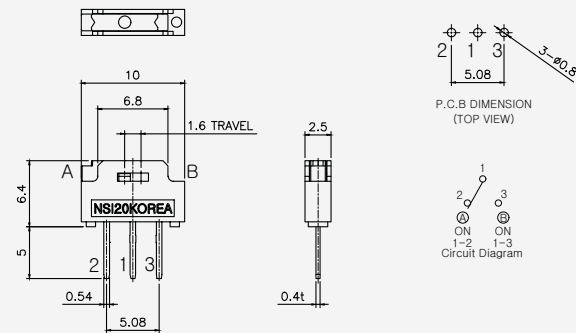

### NSI-20H Type (Switching)

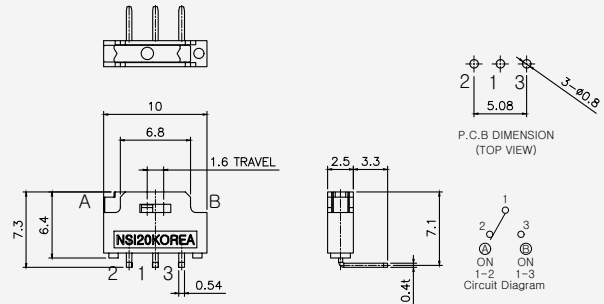

### NSI-20S Type (Switching)

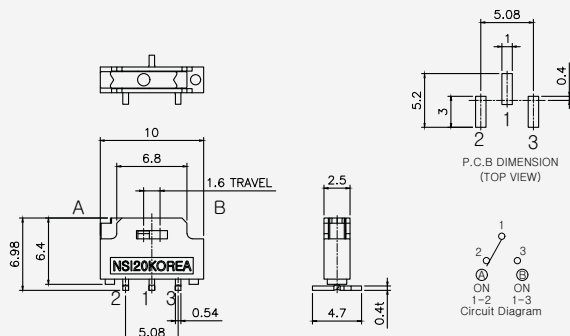

### NSI-20HS Type (Switching)

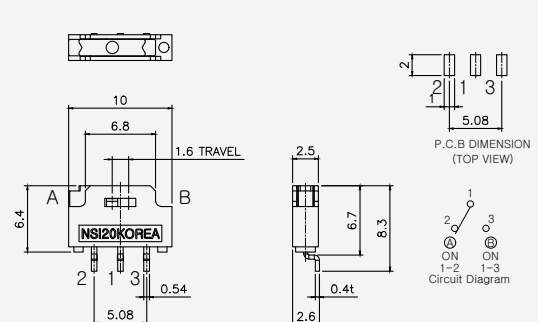

单击下面可查看定价，库存，交付和生命周期等信息

[>>SUNGMUN\(韩国星纹电子\)](#)