

Multilayer Chip Antenna – SLDA Series



Operating temp. : -40°C ~+85°C

- FEATURES**
- ◆ Light weight, compact
 - ◆ Wide bandwidth, low cost
 - ◆ Built-in antenna with high gain

- APPLICATIONS**
- ◆ Bluetooth, Wi-Fi
 - ◆ Home RF system, etc.

PRODUCT IDENTIFICATION

1	2	3	4	5	6
SLDA	31	-2R800G	-S1	T	F

1	2	3
Type	External Dimensions (L×W) (mm)	Center Frequency
SLDA	Multilayer Chip Antenna	Example Nominal Value
	15 1.0×0.5	2R800G 2800.0MHz
	18 1.6×0.8	2R450G 2450.0MHz
	31 3.2×1.6	
	52 5.2×2.1	
	62 6.0×2.0	
	72 7.0×2.0	
	81 8.0×1.0	
	92 9.0×2.0	
	106 10.0×6.0	
	154 15.0×4.0	

4	5	6
Series Code	Packing	Hazardous Substance Free Products
S1, 01, etc.	T Tape & Reel	F

SHAPE AND LAND PATTERN

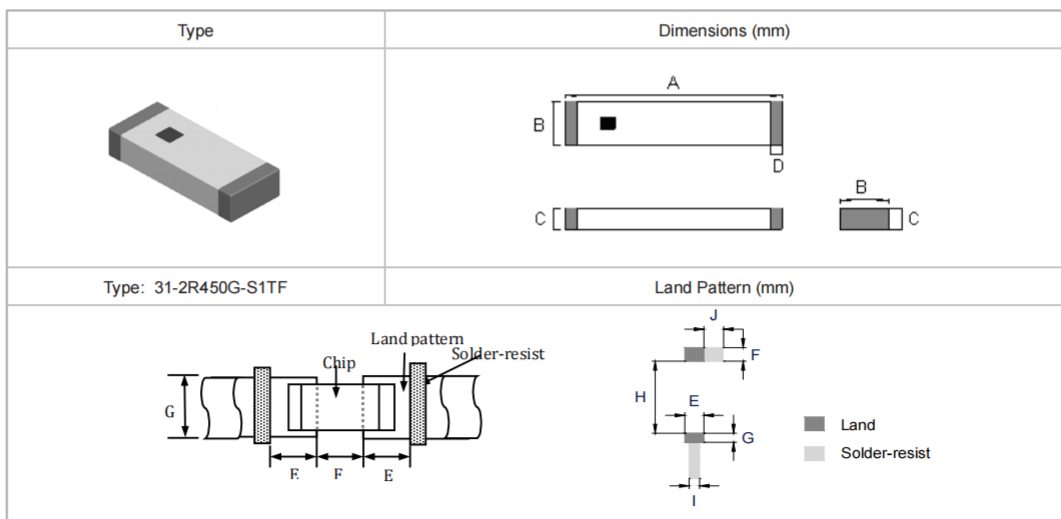

SHAPE AND DIMENSIONS

Series	A	B	C	D	E	F	G	H	I	J
SLDA15	1.00±0.1	0.5±0.1	0.4±0.05	0.25+0.1/-0.05	-	-	-	-	-	-
SLDA18	1.6±0.1	0.8±0.1	0.45±0.1	0.25±0.1	-	-	-	-	-	-
SLDA31	3.2±0.2	1.6±0.2	1.2±0.2	0.5±0.2	1.6±0.2	0.8±0.2	0.8±0.2	2.2±0.2	1.4	1.6±0.2
SLDA52	5.2±0.2	2.1±0.2	1.0±0.2	0.5±0.2	2.3±0.2	1.5±0.2	1.0±0.2	4.0±0.2	1.4	2.3±0.2
SLDA62	6.0±0.2	2.0±0.2	1.0±0.2	0.5±0.2	2.2±0.2	1.5±0.2	1.0±0.2	5.0±0.2	1.4	2.2±0.2
SLDA72	7.0±0.2	2.0±0.2	1.0±0.2	0.5±0.2	2.2±0.2	1.5±0.2	1.0±0.2	6.0±0.2	1.4	2.2±0.2
SLDA81	8.0±0.2	1.0±0.2	1.0±0.2	0.5±0.2	1.5±0.2	1.5±0.2	1.0±0.2	7.0±0.2	1.4	1.5±0.2
SLDA92	9.0±0.2	2.0±0.2	1.0±0.2	0.5±0.2	2.2±0.2	1.5±0.2	1.0±0.2	8.0±0.2	1.4	2.2±0.2
SLDA106	10.0±0.3	6.0±0.3	1.0±0.2	0.5±0.3	-	-	-	-	-	-
SLDA154	15.0±0.2	4.0±0.2	1.5±0.2	1.0±0.3	-	-	-	-	-	-

TERINAL-CONFIGURATION



No.	Terminal Name	No.	Terminal Name
(1)	Feeding Point	(2)	NC

EVALUATION BOARD

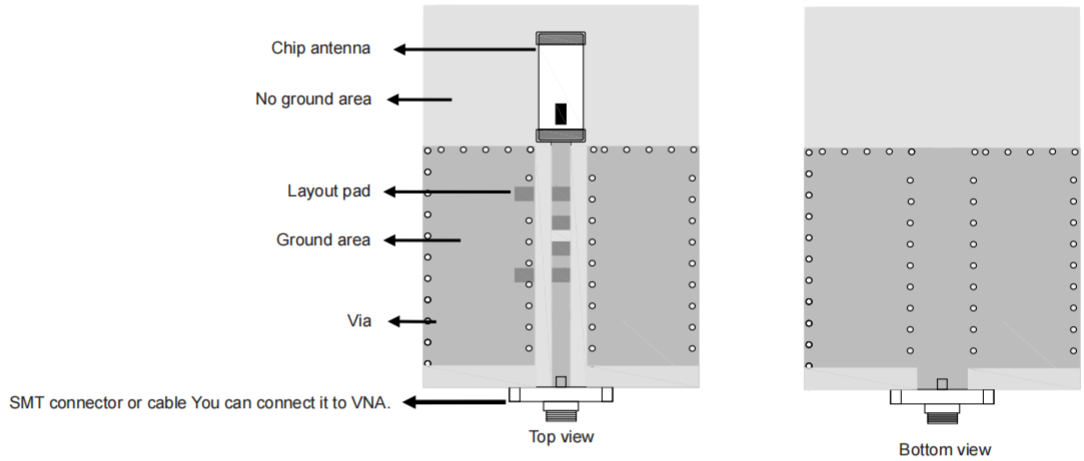

APPLICATION GUIDE

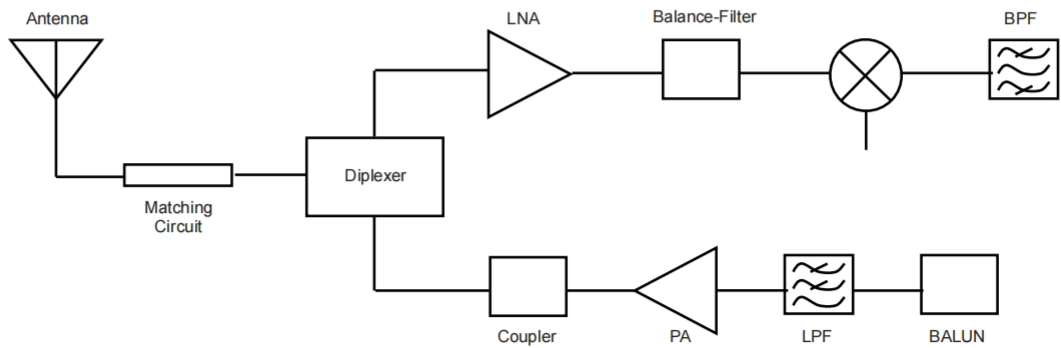

Multilayer Chip LC Filter
Multilayer Chip Balun
Multilayer Chip Diplexer
Multilayer Chip Triplexer
Multilayer Chip LC Coupler
Multilayer Chip Antenna
Wire Wound Chip Balun Transformer
Ceramic Dielectric Filter

SPECIFICATIONS SLDA15 TYPE

Part Number	Band Width	Peak Gain	Average Gain	VSWR	Impedance	Power Capacity
	MHz	V-XZ	V-XZ	In BW	Ω	W
SLDA15-2R450G-36TF	2400~2500	0.85dBi Typ.	-1.5dBi Typ.	<2	50	2

SLDA18 TYPE

Part Number	Band Width	Peak Gain	Average Gain	VSWR	Impedance	Power Capacity
	MHz	V-XZ	V-XZ	In BW	Ω	W
SLDA18-5R500G-36TF	2400~2484	-	-	6.5 max. @2400-2484 MHz	50	3
	5150~5850			4.0 max. @5150-5850 MHz		
SLDA18-2R450G-31TF	2400~2480	0.9dBi	-2.0dBi	-	50	3

SLDA31 TYPE

Part Number	Band Width	Peak Gain	Average Gain	VSWR	Impedance	Power Capacity
	MHz	V-XZ	V-XZ	In BW	Ω	W
SLDA31-2R800G-S1TF	≥ 100	0.5dBi Typ.	-1dBi Typ.	<2	50	3
SLDA31-2R450G-S1TF	≥ 100	0.5dBi Typ.	-1dBi Typ.	<2	50	3
SLDA31-2R400G-S1TF	≥ 100	2.5dBi @(XZ-total)	-1.5dBi @(XZ-total)	<2	50	3
SLDA31-2R450G-S2TF	≥ 100	2.5dBi @(XZ-total)	0.5dBi @(XZ-total)	<2	50	3
SLDA31-2R450G-36TF	2400~2500	1.7dBi	-1.0dBi	<2	50	3
SLDA31-6R050G-31TF	2400~2500	2.5dBi	-2.9dBi	<2	50	3
	4900~5850	1.5dBi	-2.1dBi			
	5850~7200	2.2dBi	-1.7dBi			
SLDA31-7R000G-31TF	5500~8500	3.5dBi	-1.3dBi	<2	50	3

SLDA52 TYPE

Part Number	Band Width	Peak Gain	Average Gain	VSWR	Impedance	Power Capacity
	MHz	V-XZ	V-XZ	In BW	Ω	W
SLDA52-2R510G-S1TF	≥ 200	2.5dBi Typ.	0.5dBi Typ.	<2	50	3
SLDA52-2R540G-S1TF	≥ 200	2.5dBi Typ.	0.5dBi Typ.	<2	50	
SLDA52-2R450G-31TF	2400~2500	0dBi	-1.5dBi	<2	50	3

SLDA62 TYPE

Part Number	Band Width	Peak Gain	Average Gain	VSWR	Impedance	Power Capacity
	MHz	V-XZ	V-XZ	In BW	Ω	W
SLDA62-2R640G-01TF	≥ 200	2.6dBi Typ.	0.7dBi Typ.	<2	50	3

SLDA72 TYPE

Part Number	Band Width	Peak Gain	Average Gain	VSWR	Impedance	Power Capacity
	MHz	V-XZ	V-XZ	In BW	Ω	W
SLDA72-0R900G-31TF	858~928	-1.1dBi	-2.5dBi	<2	50	3
SLDA72-2R470G-S1TF	≥ 200	2.7dBi Typ.	1.0dBi Typ.	<2	50	3
SLDA72-2R450G-31TF	2400~2500	1.5dBi	-0.5dBi	<2	50	3

SPECIFICATIONS SLDA81 TYPE

Part Number	Band Width	Peak Gain	Average Gain	VSWR	Impedance	Power Capacity
	MHz	V-XZ	V-XZ	In BW	Ω	W
SLDA81-3R010G-S1TF	≥ 200	2.0dBi Typ.	0.5dBi Typ.	<2	50	3

SLDA92 TYPE

Part Number	Band Width	Peak Gain	Average Gain	VSWR	Impedance	Power Capacity
	MHz	V-XZ	V-XZ	In BW	Ω	W
SLDA92-2R660G-S1TF	≥ 200	3.0dBi Typ.	1.0dBi Typ.	<2	50	3

SLDA106 TYPE

Part Number	Band Width	Peak Gain	Average Gain	VSWR	Impedance	Power Capacity
	MHz	V-XZ	V-XZ	In BW	Ω	W
SLDA106-7R000G-31TF	3100~10300	2.2dBi	-3.5dBi.	<2	50	3

SLDA154 TYPE

Part Number	Band Width	Peak Gain	Average Gain	VSWR	Impedance	Power Capacity
	MHz	V-XZ	V-XZ	In BW	Ω	W
SLDA154-2R200G-31TF	700~800 MHz 1700~2100 MHz	2.0dBi.	-1.6dBi	<2	50	3
	824~960 MHz 1710~2690 MHz	2.0dBi	-1.0dBi			

※Frequency will be changed with layout of PCB. Please contact us for appropriate design.

IMPEDANCE MATCHING

SLDA15-2R450G-36TF

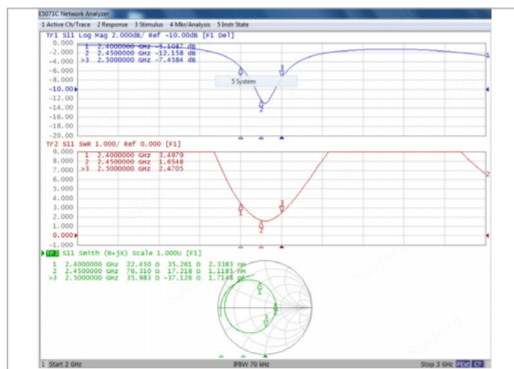

SLDA18-5R500G-36TF

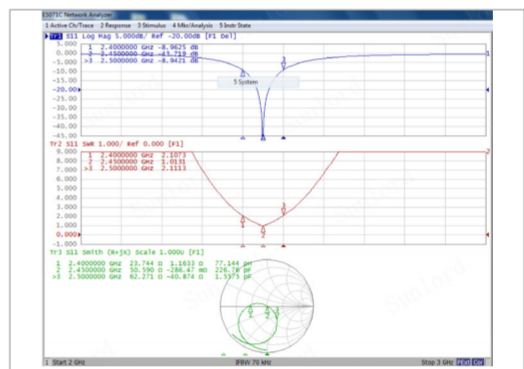

SLDA18-2R450G-31TF

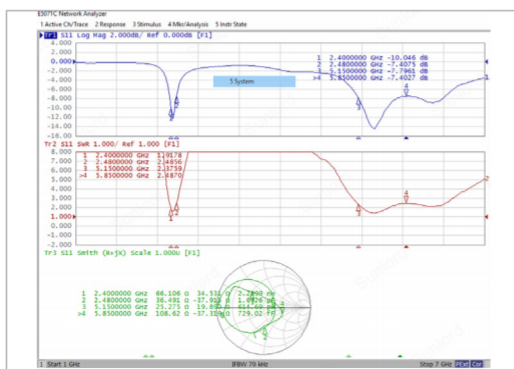

SLDA31-2R800G-S1TF

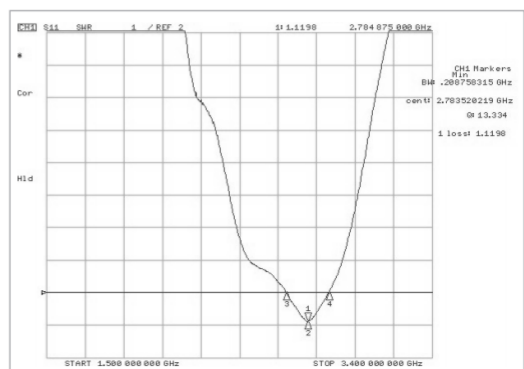

Multilayer Chip LC Filter
Multilayer Chip Balun
Multilayer Chip Diplexer
Multilayer Chip Triplexer
Multilayer Chip LC Coupler
Multilayer Chip Antenna
Wire Wound Chip Balun Transformer
Ceramic Dielectric Filter

IMPEDANCE MATCHING

SLDA31-2R400G-S1TF

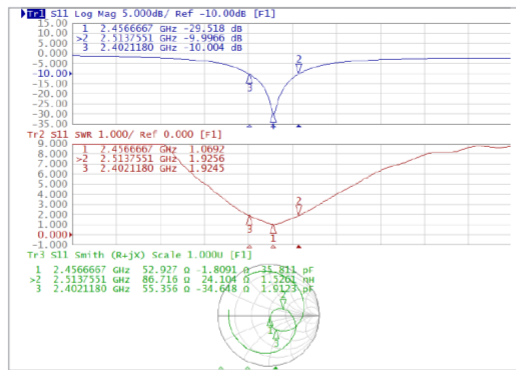

SLDA31-2R450G-S1TF

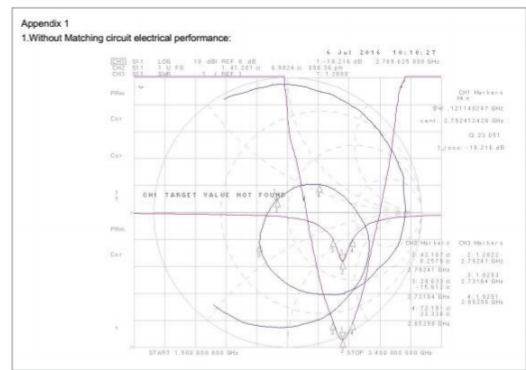

SLDA31-2R450G-S2TF

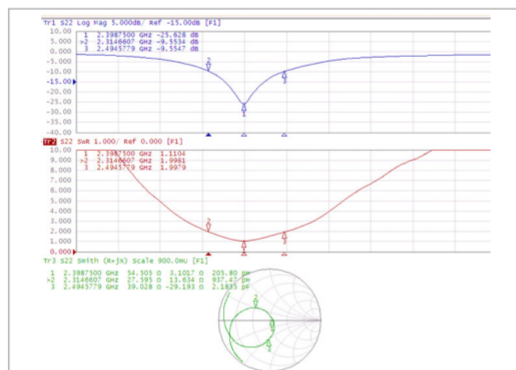

SLDA31-2R450G-36TF

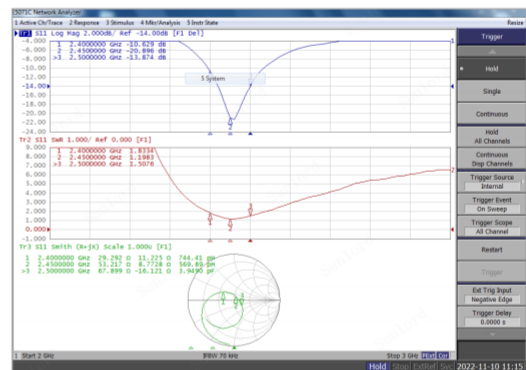

SLDA31-6R050G-31TF

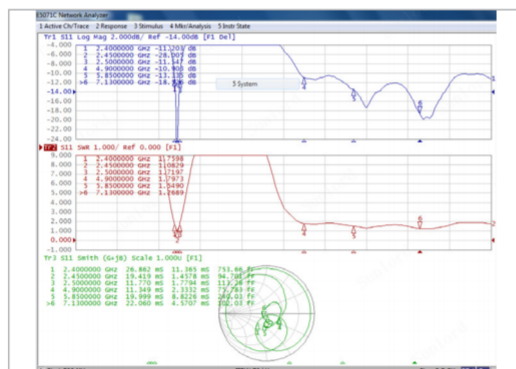

SLDA31-7R000G-31TF

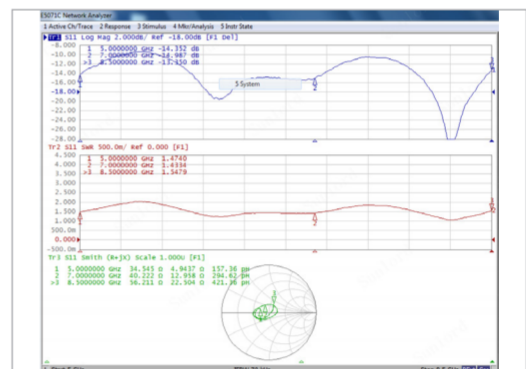

SLDA52-2R450G-31TF

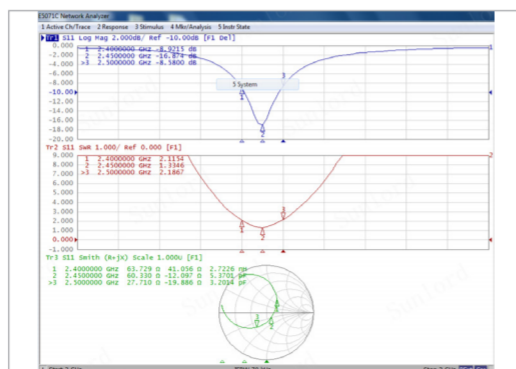

SLDA52-2R510G-S1TF

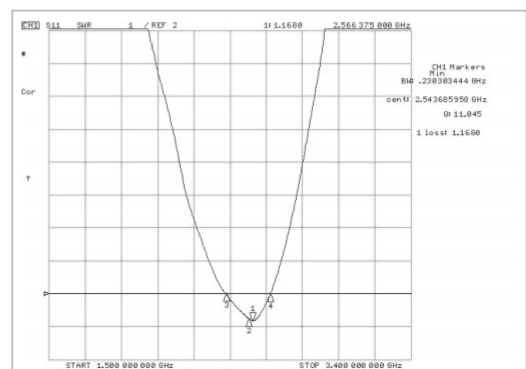

IMPEDANCE MATCHING

SLDA52-2R540G-S1TF

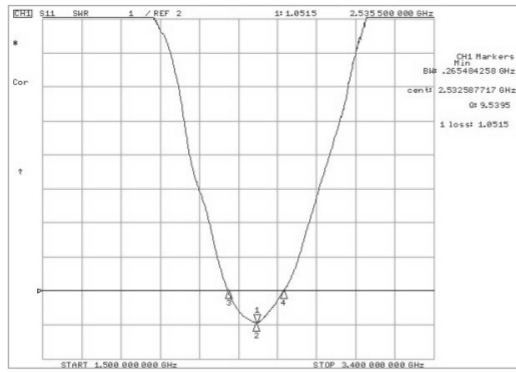

SLDA62-2R640G-01TF

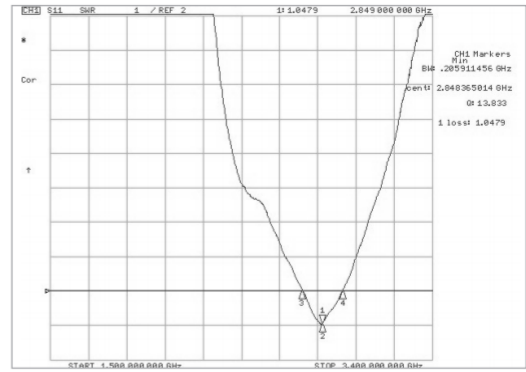

SLDA72-0R900G-31TF

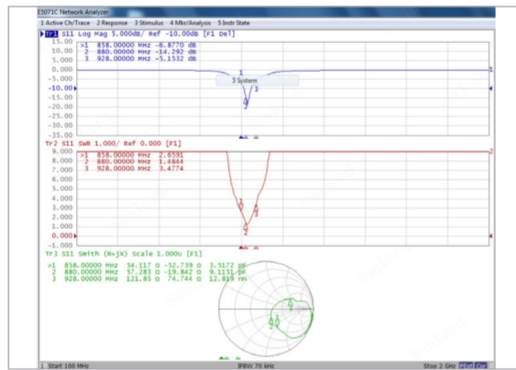

SLDA72-2R470G-S1TF

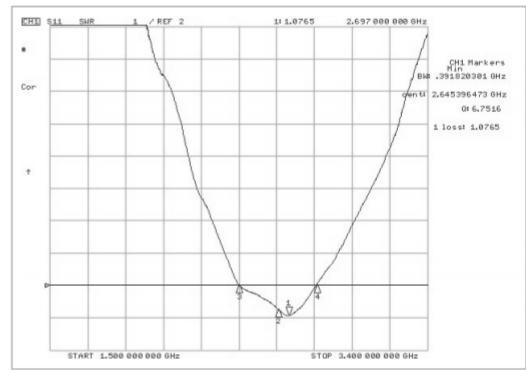

SLDA72-2R450G-31TF

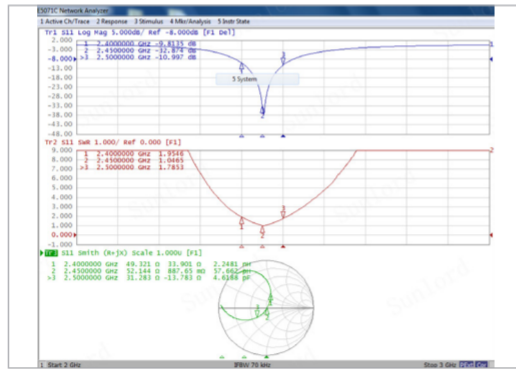

SLDA81-3R010G-S1TF

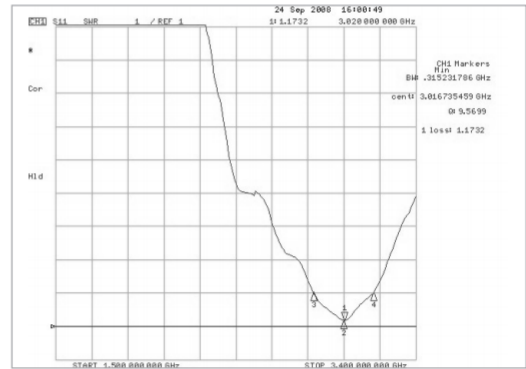

SLDA92-2R660G-S1TF

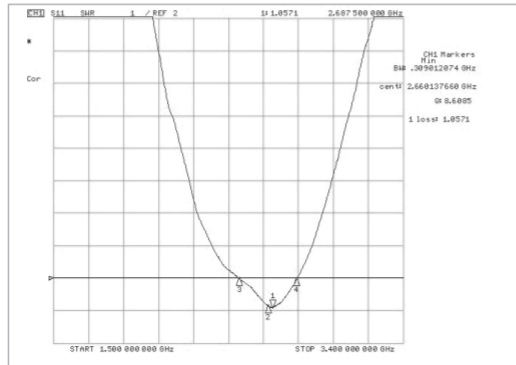

SLDA106-7R000G-31TF

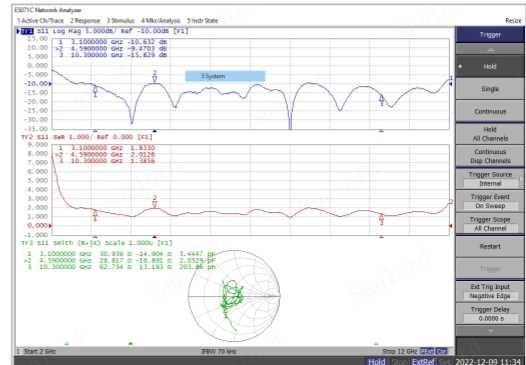

IMPEDANCE MATCHING

SLDA154-2R200G-31TF

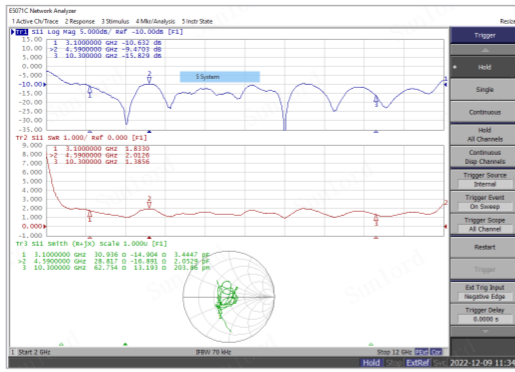

单击下面可查看定价，库存，交付和生命周期等信息

[>>Sunlord\(顺络\)](#)