

Description

The 1210 series provides miniature surface mount over-current protection with holding current from 0.05A to 2.60A. This series is suitable for wide range of applications in modern electronics where space is limited

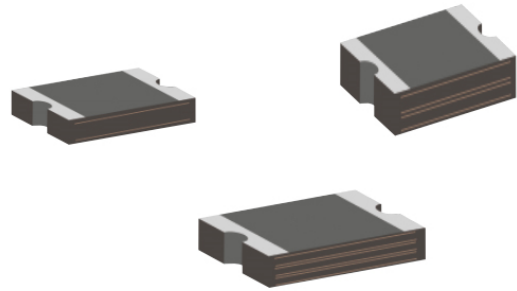

Features

- I I(hold): 0.05~2.60A
- I Very high voltage surge capabilities
- I Available in lead-free version
- I Fast response to fault current
- I RoHS compliant, Lead- Free and Halogen-Free
- I Low resistance
- I Compact design saves board space
- I Compatible with high temperature solders

Applications

- I USB peripherals
- I Disk drives
- I CD-ROMs
- I General electronics
- I Disk drives
- I Set-top-box and HDMI
- I Mobile Internet Device (MID)
- I PDAs / digital cameras
- I Game console port protection
- I Plug and play protection for motherboards and peripherals
- I Mobile phones - battery and port protection

Part Number Code

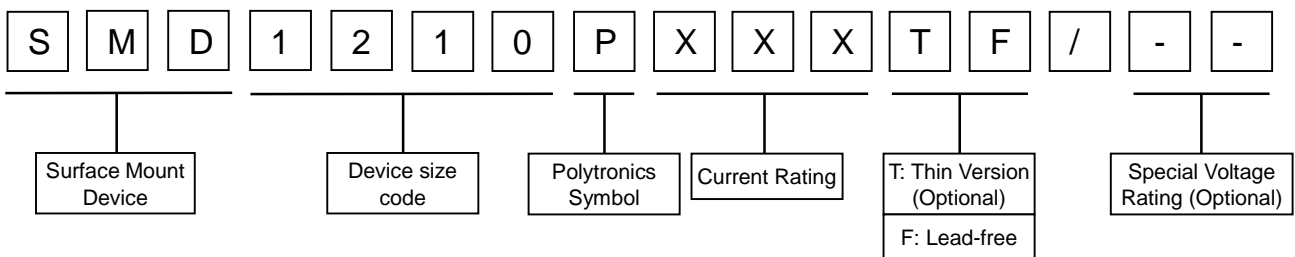

Environmental Specifications

Test	Test Conditions	Accept/Reject Criteria
Resistance	In still air @ 25°C	$R_{min} \leq R \leq R_{max}$
Time to Trip	Specified current, V_{max} , 25°C	$T \leq$ maximum Time to Trip
Hold Current	30min, at I_H	No trip
Trip Cycle Life	V_{max} , I_{max} , 100cycles	No arcing or burning
Trip Endurance	V_{max} , 1 hours	No arcing or burning

Physical Characteristics and Environmental Specifications

Terminal materials :	Tin-Plated Nickle-copper	
Soldering zone	Meets EIA specification RS 186-9E and ANSI/J-STD-002 Category 3.	
Environmental Specifications		
Test	Conditions	Resistance Change
Passive aging	85°C, 1000hours	±10%
Humidity aging	85°C/85%RH. 1000 hours	±5%
Thermal shock	MIL-STD-202, Method 107G +85°C/-40°C, 20times	-30% typical resistance change
Solvent Resistance	MIL-STD-202, Method 215	no change
Vibration	ML-STD-883C, Test Condition A	No change

Electrical Characteristic

Part Number	V _{Max} (Vdc)	I _{Max} (A)	I _{Hold} (A)	I _{Trip} (A)	P _D Max. (W)	Maximum Time-to-trip		Resistance	
						Current (A)	Time (Sec)	R _{Min} (Ω)	R _{1Max} (Ω)
SMD1210P005TF	60	100	0.05	0.15	0.6	0.25	1.50	2.8	50
SMD1210P010TF	30	100	0.10	0.30	0.6	0.50	0.60	0.8	15
SMD1210P020TF	30	100	0.20	0.40	0.6	8.0	0.02	0.40	5
SMD1210P035TF/30	30	100	0.35	0.75	0.6	8.0	0.20	0.20	1.3
SMD1210P035TF	16	100	0.35	0.75	0.6	8.0	0.20	0.20	1.3
SMD1210P050TF	16	100	0.50	1.00	0.6	8.0	0.10	0.18	0.9
SMD1210P075TF	6	100	0.75	1.50	0.6	8.0	0.10	0.07	0.4
SMD1210P075TF/24	24	100	0.75	1.50	0.6	8.0	0.10	0.07	0.45
SMD1210P110TF	6	100	1.10	2.20	0.6	8.0	0.30	0.05	0.21
SMD1210P110TF/12	12	100	1.10	2.20	0.8	8.0	0.30	0.05	0.25
SMD1210P110TF/16	16	100	1.10	2.20	0.8	8.0	0.30	0.05	0.25
SMD1210P150TF	6	100	1.50	3.00	0.8	8.0	0.50	0.03	0.11
SMD1210P175TF	6	100	1.75	3.50	0.8	8.0	0.60	0.02	0.08
SMD1210P200TF	6	100	2.00	4.00	0.8	8.0	1.00	0.015	0.07

V_{max} = Maximum operating voltage device can withstand without damage at rated current (I_{max}).

I_{max} = Maximum fault current device can withstand without damage at rated voltage (V_{max}).

I_{hold} = Hold Current. Maximum current device will not trip in 25°C still air.

I_{trip} = Trip Current. Minimum current at which the device will always trip in 25°C still air.

P_d = Power dissipation when device is in the tripped state in 25°C still air environment at rated voltage.

R_{i min/max} = Minimum/Maximum device resistance prior to tripping at 25°C.

R_{1max} = Maximum device resistance is measured one hour post reflow.

Thermal Derating Chart-I_H (A)

Part Number	Maximum ambient operating temperatures (°C)								
	-40	-20	0	25	40	50	60	70	85
SMD1210P005TF	0.08	0.07	0.06	0.05	0.04	0.04	0.03	0.03	0.02
SMD1210P010TF	0.16	0.14	0.12	0.10	0.08	0.07	0.06	0.05	0.05
SMD1210P020TF	0.29	0.26	0.22	0.20	0.16	0.14	0.13	0.11	0.08
SMD1210P035TF	0.47	0.45	0.40	0.35	0.33	0.28	0.24	0.21	0.18
SMD1210P035TF/30	0.47	0.45	0.40	0.35	0.33	0.28	0.24	0.21	0.18
SMD1210P050TF	0.76	0.67	0.58	0.50	0.43	0.40	0.36	0.32	0.28
SMD1210P075TF	1.00	0.97	0.86	0.75	0.64	0.59	0.54	0.48	0.40
SMD1210P075TF/24	1.00	0.97	0.86	0.75	0.64	0.59	0.54	0.48	0.40
SMD1210P110TF	1.60	1.42	1.26	1.10	0.94	0.86	0.80	0.70	0.58
SMD1210P110TF/12	1.60	1.42	1.26	1.10	0.94	0.86	0.80	0.70	0.58
SMD1210P110TF/16	1.60	1.42	1.26	1.10	0.94	0.86	0.80	0.70	0.58
SMD1210P150TF	2.30	2.02	1.76	1.50	1.24	1.11	1.00	0.85	0.65
SMD1210P175TF	2.45	2.22	2.01	1.75	1.45	1.26	1.10	0.98	0.80
SMD1210P200TF	2.60	2.44	2.35	2.00	1.78	1.67	1.50	1.45	1.10

Thermal Derating Curve

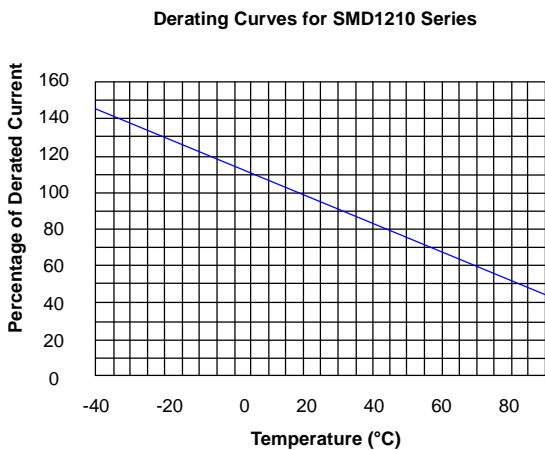

Average Time-Current Curve

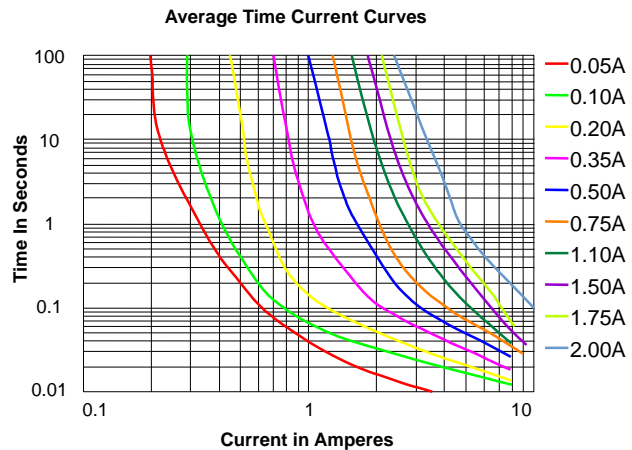

Soldering Parameters

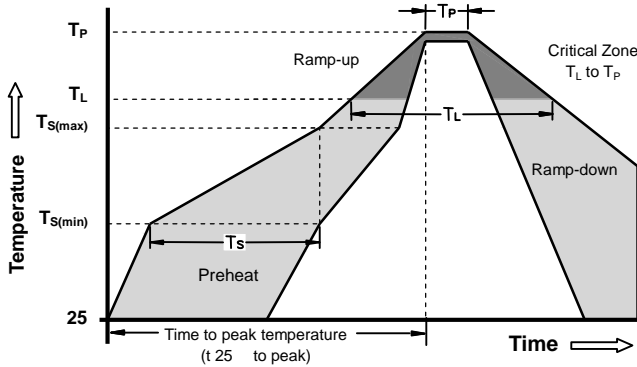

Reflow Condition		Pb - Free assembly
Pre Heat	-Temperature Min ($T_{s(min)}$)	150°C
	-Temperature Max ($T_{s(max)}$)	200°C
	- Time (min to max) (t_s)	60 -180 Seconds
Average ramp up rate (Liquids Temp T_L) to peak		3°C/second max
$T_{s(max)}$ to T_L - Ramp-up Rate		3°C/second max
Reflow	- Temperature (T_L) (Liquids)	217°C
	- Time (min to max) (t_s)	60 -150 Seconds
Peak Temperature (T_P)		260 +0/-5°C
Time within 5°C of actual peak Temperature (t_p)		20 - 40 Seconds
Ramp-down Rate		6°C/second max
Time 25°C to peak Temperature (T_P)		8 minutes Max
Do not exceed		260°C

Recommended pad layout (mm)

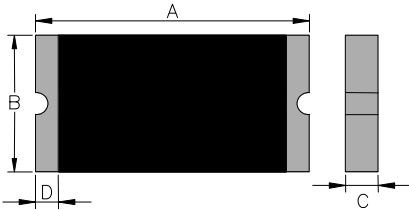
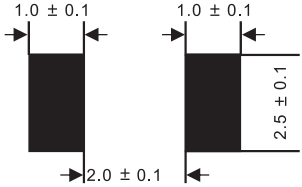
Lead style code	Recommended Pad Layout (mm.)
	

Product Dimensions

Unit : mm

Part Number	Marking	A		B		C		D	E
		Max	Min	Max	Min	Max	Min	Min	Min
SMD1210P005TF	JN	3.00	3.43	2.35	2.80	0.60	1.25	0.15	0.10
SMD1210P010TF	JN	3.00	3.43	2.35	2.80	0.60	1.25	0.15	0.10
SMD1210P020TF	JF	3.00	3.43	2.35	2.80	0.50	1.00	0.15	0.10
SMD1210P035TF	JB	3.00	3.43	2.35	2.80	0.35	0.90	0.15	0.10
SMD1210P035TF/30	JB	3.00	3.43	2.35	2.80	0.35	1.00	0.15	0.10
SMD1210P050TF	JG	3.00	3.43	2.35	2.80	0.35	0.90	0.15	0.10
SMD1210P075TF	JA	3.00	3.43	2.35	2.80	0.35	0.85	0.15	0.10
SMD1210P075TF/24	JA	3.00	3.43	2.35	2.80	0.50	1.10	0.15	0.10
SMD1210P110TF	JK	3.00	3.43	2.35	2.80	0.40	1.00	0.15	0.10
SMD1210P110TF/12	JK	3.00	3.43	2.35	2.80	0.50	1.10	0.15	0.10
SMD1210P110TF/16	JK	3.00	3.43	2.35	2.80	0.50	1.10	0.15	0.10
SMD1210P150TF	JK	3.00	3.43	2.35	2.80	0.60	1.40	0.15	0.10
SMD1210P175TF	JK	3.00	3.43	2.35	2.80	0.60	1.40	0.15	0.10
SMD1210P200TF	JK	3.00	3.43	2.35	2.80	0.60	1.50	0.15	0.10

Taping and Reel Specifications

Covering Specifications EIA 481-1(Unit:mm)	
W	8.0± 0.3
P ₀	4.0 ± 0.10
P ₁	4.0 ± 0.10
P ₂	2.0 ± 0.05
A ₀	2.87± 0.10
B ₀	3.56± 0.10
D ₀	1.55 ± 0.05
F	3.5 0± 0.05
E ₁	1.75 ± 0.10
T	0.25 ± 0.10
Leader min.	390
Trailer min.	160
Reel Dimensions	
A	178±1.0
N	59±1
W ₁	8.5+1.0/-0.2
W ₂	12.0±1

EIA Tape Component Dimensions

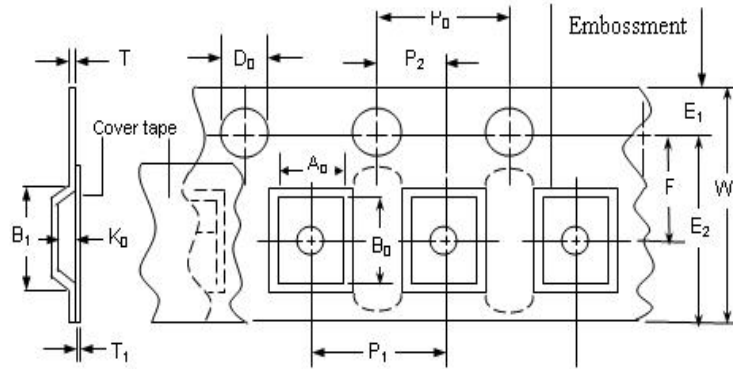

EIA Reel Dimensions

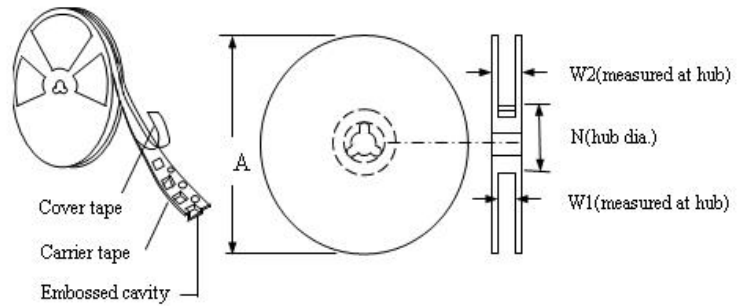

Packaging Quantity

Quantity	3000		4000	
Part Number	SMD1210P175TF	SMD1210P200TF	SMD1210P005TF	SMD1210P010TF
			SMD1210P020TF	SMD1210P035TF/30
			SMD1210P035TF	SMD1210P050TF
			SMD1210P075TF	SMD1210P075TF/24
			SMD1210P110TF	SMD1210P110TF/12
			SMD1210P110TF/16	SMD1210P150TF

单击下面可查看定价，库存，交付和生命周期等信息

[>>SUNMATE\(森美特\)](#)