



Function

1. High-speed switching

Since release time is 0.1 ms, the MOSFET or other load can be turned off quickly in urgent situations.

2. Space saving

With a built-in control circuit, an external resistor is not needed. This contributes to making substrates more compact.

Applications

These advantages make APSEI Photorelays the ideal choice for:

MOSFET driver

Power supply (Vcc) for electronic circuits



SOP-4

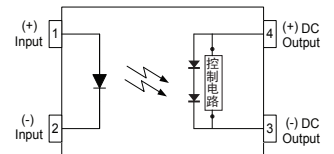
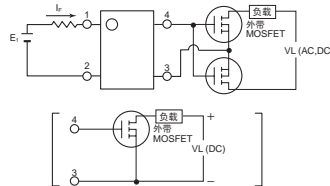

1. LED Anode
2. LED Cathode
3. Cathode
4. Anode

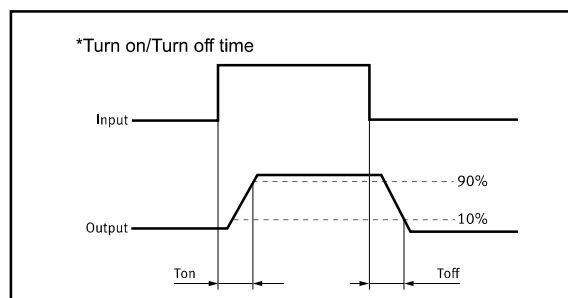

TYPES

Category	Output Rating		Package	Part No.	Packing Quantity
	Drop-out voltage (Typ.)	Short circuit current (Typ.)			
Driver	12V	8uA	SOP-4	GAQV1123S	2000pcs /reel

Absolute Maximum Ratings (Ta = 25°C)

Item		Symbol	Value	Units	Note
Input	Continuous LED Current	I _F	50	mA	
	Peak LED Current	I _{FP}	1000	mA	f=100Hz, duty=1%
	LED Reverse Voltage	V _R	5	V	
	Input Power Dissipation	P _{In}	75	mW	
I/O Breakdown Voltage		V _{I/O}	2500	V _{rm}	RH=60%, 1min
Operating Temperature		T _{Opr}	-40 to +85	°C	
Storage Temperature		T _{Stg}	-40 to +100	°C	

Electrical Characteristics (Ta = 25°C)

Item		Symbol	MIN.	TYP.	MAX.	Units	Conditions
Input	LED Forward Voltage	V _F		1.2	1.4	V	I _F =10mA
	Operation LED Current	I _{F On}		0.5	3.0	mA	V _{oc} =5V
	Recovery LED Current	I _{F Off}		0.35	0.5	mA	V _{oc} =1V
Output	Drop-out Voltage	V _{oc}	10	12		V	I _F =10mA
	Short Circuit Current	I _{sc}	1	8		uA	I _F =10mA
Transmis sion	Turn-On Time	T _{On}		0.23		ms	I _F =10mA
	Turn-Off Time	T _{of}		0.03		ms	C _L =1000pF
Coupled	I/O Isolation Resistance	R _{I/O}	10 ¹⁰			Ω	DC500V
	I/O Capacitance	C _{I/O}		0.8	1.5	pF	f=1MHz

Please obey the following conditions to ensure proper device operation and resetting. Input LED current (Recommended value): I_F ≥5mA and ≤30mA.
 Examples of resistance value to control LED forward current (I_F=5mA, INPUT VOLTAGE="E", RESISTORS="R")
 "E"=3.3V, "R"=330Ω; "E"=5V, "R"=640Ω; "E"=12V, "R"=1.9KΩ; "E"=15V, "R"=2.5KΩ; "E"=24V, "R"=4.1KΩ;

Reference Data

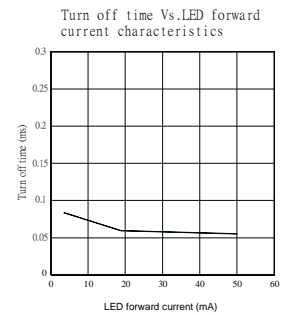
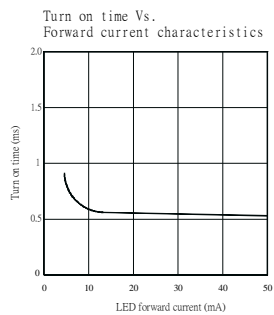
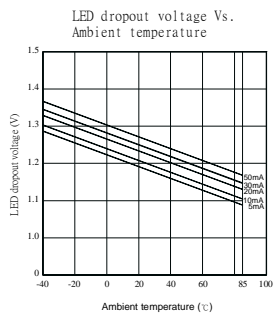
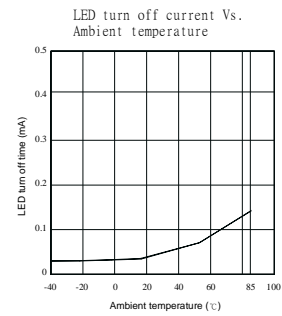
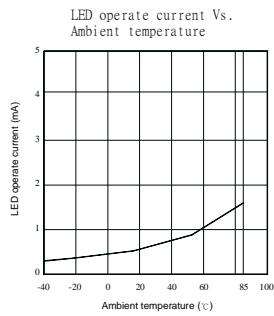
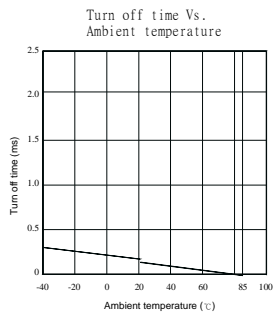
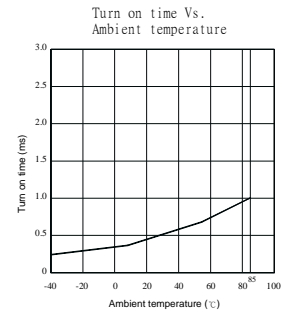
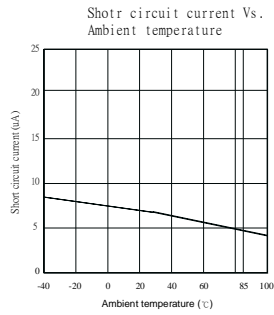
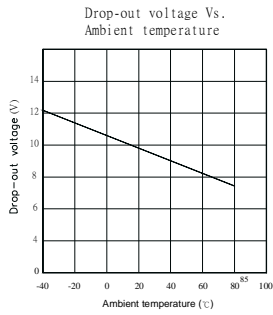

Dimensions

4-SOP

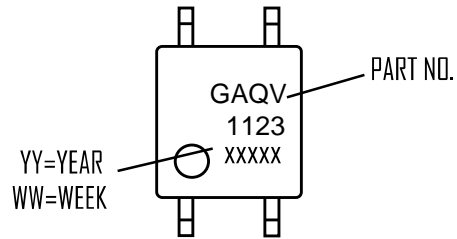

Surface mount terminal type

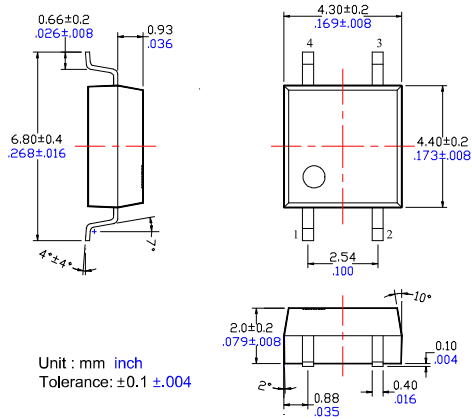

Recommended mounting pad (Top view)

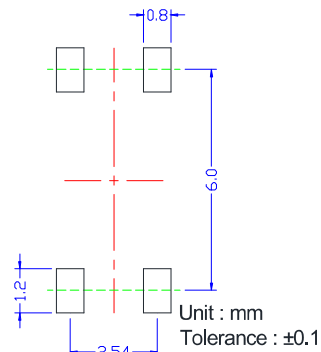

Tape dimensions

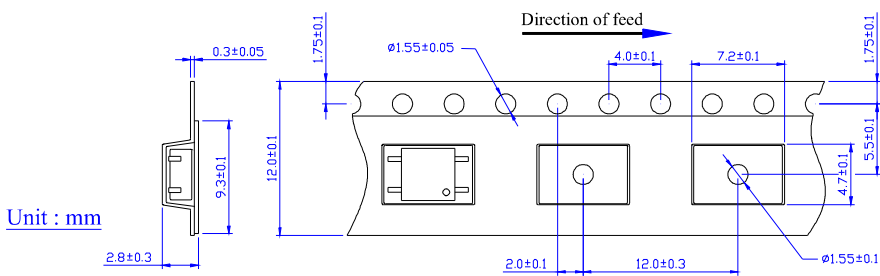

Dimensions of tape reel

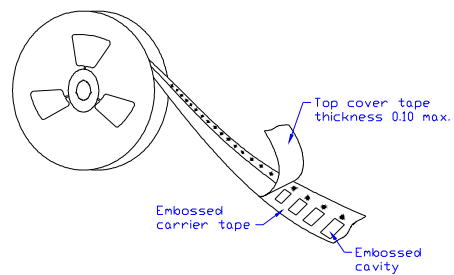
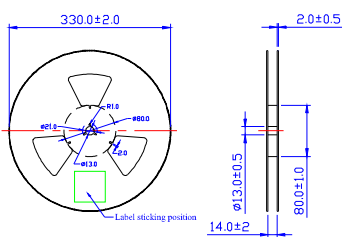

单击下面可查看定价，库存，交付和生命周期等信息

[>>SUPSiC\(国晶微\)](#)