



Features

- Low driver power requirements (TTL/CMOS Compatible)
- No moving parts
- High reliability
- Arc-Free with no snubbing circuits
- 3750Vrms Input/Output isolation

Applications

- Telecommunications (PC, Electronic notepad)
- Measuring and Testing equipment
- Industrial control
- Security equipments
- High speed inspection machine

Outline Dimensions



DIP4



SMD4

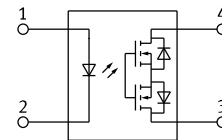

1. LED Anode
2. LED Cathode
- 3, 4. Drain (MOS FET)

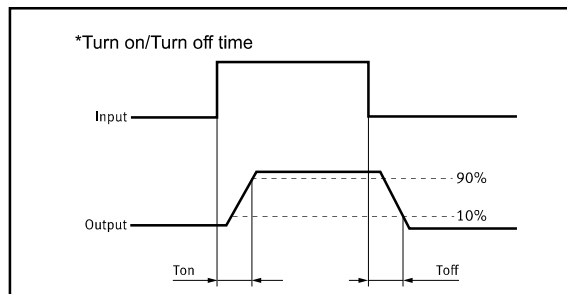

TYPES

Category	Output rating		Package	Part No.	Packing quantity
	Load voltage	Load current			
AC/DC	60V	0.5A	DIP4	GAQY212E	50pcs/tube
			SMD4	GAQY212EH	1000pcs/reel

Absolute Maximum Ratings (Ambient Temperature: 25 °C)

Item		Symbol	Value	Units	Note
Input	Continuous LED Current	I_F	50	mA	
	Peak LED Current	I_{FP}	1000	mA	f=100Hz, duty=1%
	LED Reverse Voltage	V_R	5	V	
	Input Power Dissipation	P_{in}	75	mW	
Output	Load Voltage	V_L	60	V(AC peak or DC)	
	Load Current	I_L	0.5	A	
	Peak Load Current	I_{Peak}	1.5	A	100ms(1 pulse)
	Output Power Dissipation	P_{out}	380	mW	
Total Power Dissipation		P_T	500	mW	
I/O Breakdown Voltage		$V_{I/O}$	5000	V _{rm}	RH=60%, 1min
Operating Temperature		T_{opr}	-40 to +85	°C	
Storage Temperature		T_{stg}	-40 to +100	°C	
Pin Soldering Temperature		T_{sol}	260	°C	10 sec max.

Electrical Specifications (Ambient Temperature: 25 °C)

Item		Symbol	MIN.	TYP.	MAX.	Units	Conditions
Input	LED Forward Voltage	V_F	1.14	1.32	1.47	V	$I_F=10mA$
	Operation LED Current	$I_{F on}$		0.5	5.0	mA	
	Recovery LED Current	$I_{F off}$		0.35	0.5	mA	
	Recovery LED Voltage	$V_{F off}$	0.7			V	
Output	On-Resistance	R_{on}		0.80	2.5	Ω	$I_F=10mA, I_L=1Amp$ Within 10ms on time
	Off-State Leakage Current	I_{Leak}			1	uA	$I_F=0mA, V_L=50V$
	Output Capacitance	C_{out}		105		pF	f=1MHz
Transmission	Turn-On Time	T_{on}		1.50	4	ms	$I_F=5mA, I_L=100mA$
	Turn-Off Time	T_{off}		0.05	1	ms	
Coupled	I/O Isolation Resistance	$R_{I/O}$	5			GΩ	DC=500V
	I/O Capacitance	$C_{I/O}$		0.8	1.5	pF	f=1MHz

Please obey the following conditions to ensure proper device operation and resetting. Input LED current (Recommended value): $I_F \geq 5mA$ and $\leq 30mA$.

Examples of resistance value to control LED forward current ($I_F=5mA, INPUT VOLTAGE="E", RESISTORS="R"$)

"E"=3.3V,"R"=330Ω; "E"=5V,"R"=640Ω; "E"=12V,"R"=1.9KΩ; "E"=15V,"R"=2.5KΩ; "E"=24V,"R"=4.1KΩ;

Reference Data

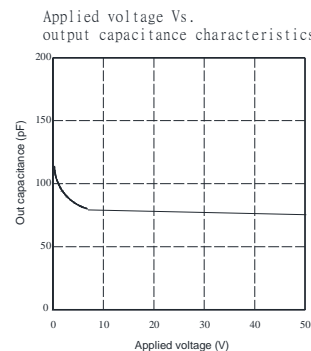
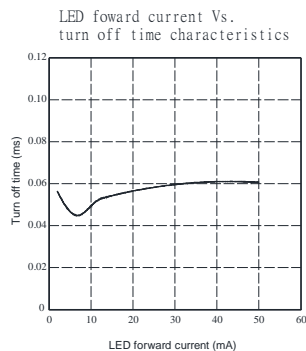
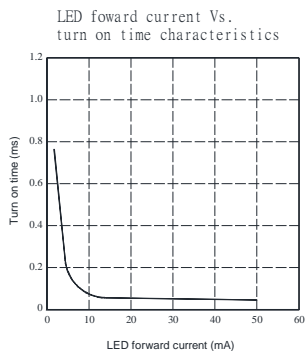
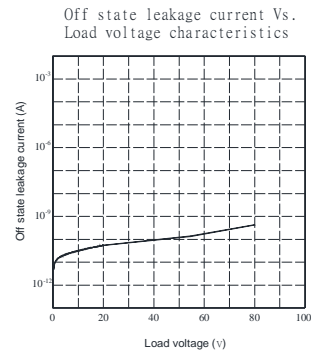
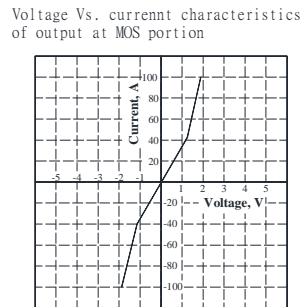
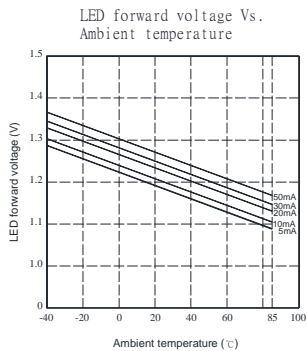
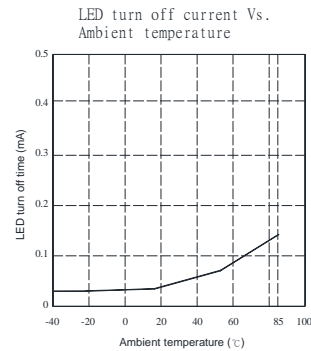
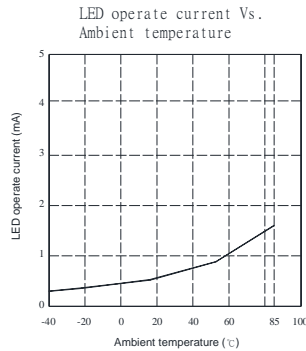
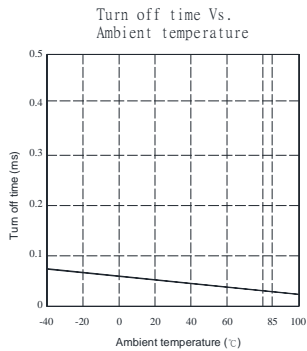
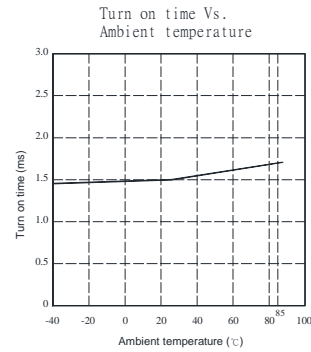
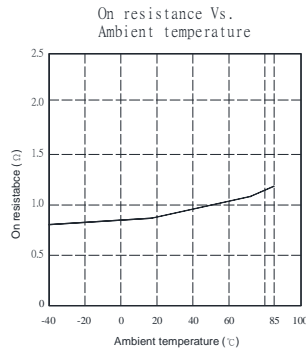
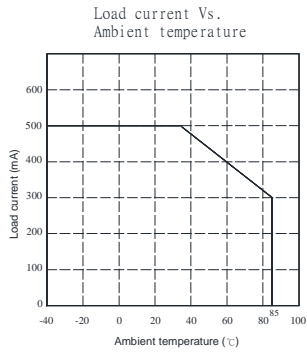

Dimensions

4-SMD



Dimensions

mm inch

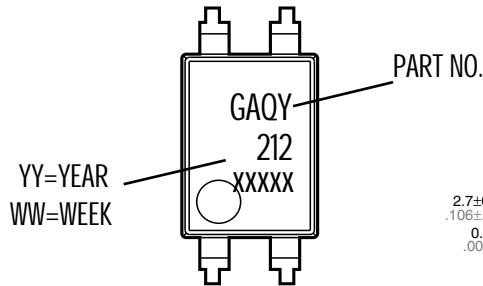

Surface mount terminal type

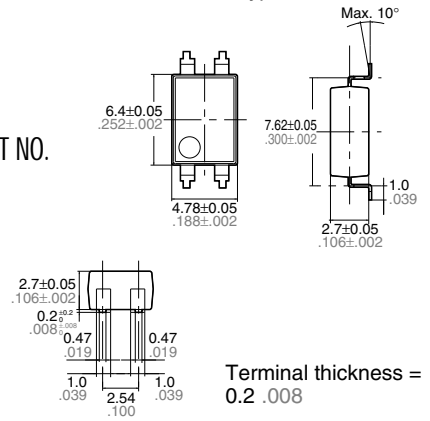

Terminal thickness = 0.2 .008

General tolerance: ±0.1 ±0.04

PC board pattern (Top view)

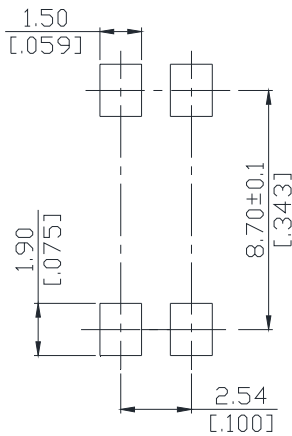

Unit : mm [inch]
Tolerance : ±0.1

Tape dimensions

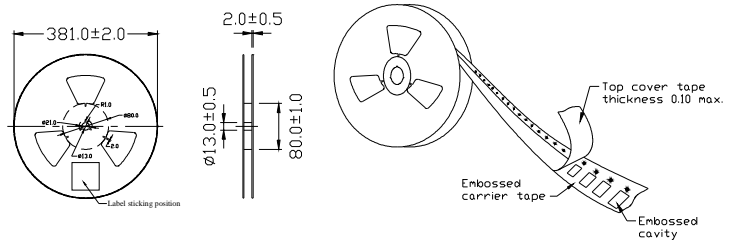

Dimensions of tape reel

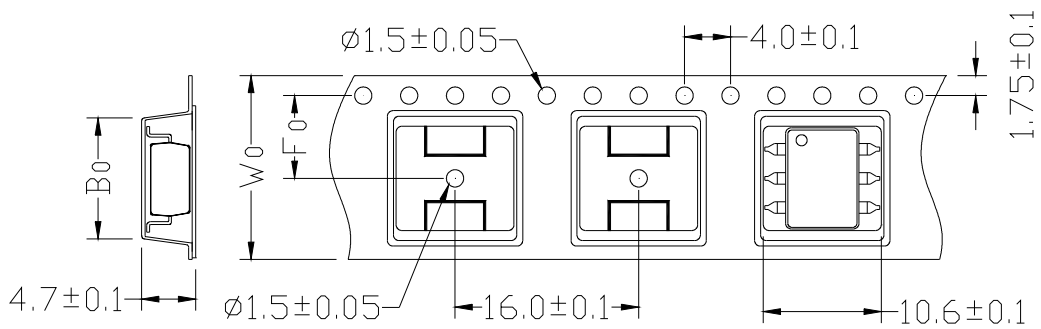

Unit: mm

TYPE	B0±0.1	F0±0.1	W0±0.1	13"REEL/PCS
4P	5.3	7.5	16	1000

Dimensions

4-DIP

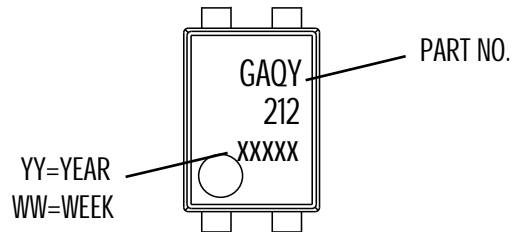

mm inch

Dimensions

Through hole terminal type

PC board pattern

(TOP VIEW)

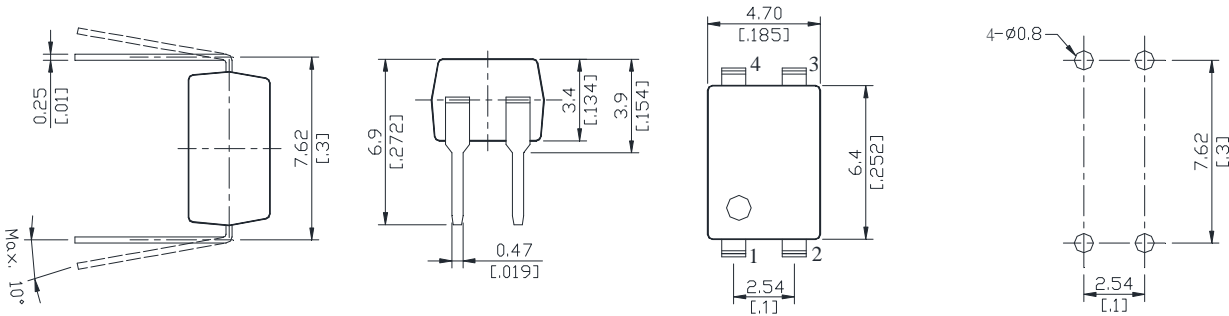

Unit : mm inch
 Tolerance: +0.2 +.007

DIP type

Devices are packaged in a tube so that pin No. 1 is on the stopper B side. Observe correct orientation when mounting them on PC boards.

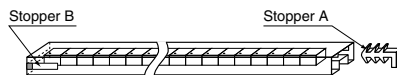

单击下面可查看定价，库存，交付和生命周期等信息

[>>SUPSiC\(国晶微\)](#)