



# TAI-SAW TECHNOLOGY CO., LTD.

No. 3, Industrial 2nd Rd., Ping-Chen Industrial District,  
Taoyuan, 324, Taiwan, R.O.C.

TEL: 886-3-4690038 FAX: 886-3-4697532

E-mail: [tstsales@mail.taisaw.com](mailto:tstsales@mail.taisaw.com) Web: [www.taisaw.com](http://www.taisaw.com)

## Product Specifications Approval Sheet

Product Description: SAW Filter 2350 MHz 100MHz BW Band40 SMD 1.1X0.9 mm

TST Part No.: TA1969A

Customer Part No.: \_\_\_\_\_

Customer signature required
Company: _____
Division: _____
Approved by : _____
Date: _____

Checked by: \_\_\_\_\_ Anne Chen *Anne Chen*

Approved by: \_\_\_\_\_ Andy Yu *Andy Yu*

Date: \_\_\_\_\_ 2018/02/26

1. Customer signed back is required before TST can proceed with sample build and receive orders.
2. Orders received without customer signed back will be regarded as agreement on the specifications.
3. Any specifications changes must be approved upon by both parties and a new revision of specifications shall be released to reflect the changes.



# TAI-SAW TECHNOLOGY CO., LTD.

No. 3, Industrial 2nd Rd., Ping-Chen Industrial District,  
Taoyuan, 324, Taiwan, R.O.C.

TEL: 886-3-4690038 FAX: 886-3-4697532

E-mail: [tstsales@mail.taisaw.com](mailto:tstsales@mail.taisaw.com) Web: [www.taisaw.com](http://www.taisaw.com)

## SAW Filter 2350MHz 100MHz BW SMD1.1x0.9mm

MODEL NO.:TA1969A

REV. NO.:2

### A. MAXIMUM RATING:

1. Input Power Level: 10dBm
2. DC Voltage : 0V
3. Operating Temperature: -30°C to +85°C
4. Storage Temperature: -40°C to +85°C
5. Moisture Sensitivity Level: Level 3
6. ESD 50V(MM) 100V(HBM)

RoHS Compliant  
Lead free  
Lead-free soldering

Electrostatic Sensitive Device (ESD)

### B. ELECTRICAL CHARACTERISTICS:

Terminating source impedance :  $Z_s = 50 \Omega$

Terminating load impedance :  $Z_L = 50 \Omega$

Item	Unit	Min.	Typ.	Max.	Note
<b>Center Frequency</b> <b>Fc</b>	MHz	-	2350	-	-
<b>Insertion Loss</b> (2300~2400 MHz) <b>IL</b>	dB	-	1.9	2.8	-
<b>Amplitude ripple</b> (2300~2400 MHz)	dBp-p	-	1.2	2.3	-
<b>VSWR</b> (2300~2400 MHz)		-	1.5	2.0	-
<b>Attenuation</b> (reference level from 0 dB)					
10 ~ 1574 MHz	dB	20	29	-	-
1574 ~ 1577 MHz	dB	20	29		
1577 ~ 1680 MHz	dB	20	27		
1845 ~ 1880 MHz	dB	18	25	-	-
2110 ~ 2170 MHz	dB	18	25	-	-
2240 ~ 2285 MHz	dB	1.5	7	-	-
2415 ~ 2420 MHz	dB	1.5	5	-	-
2420 ~ 2460 MHz	dB	3	6	-	-
2460 ~ 2485 MHz	dB	30	43	-	-
2485 ~ 2500 MHz	dB	30	48		
2500 ~ 3000 MHz	dB	20	26		
4600 ~ 4800 MHz	dB	20	25		
4800 ~ 6000 MHz	dB	18	21		
<b>Temperature Coefficient of Frequency</b>	ppm/°C	-	-36	-	-

### C. OUTLINE DRAWING:

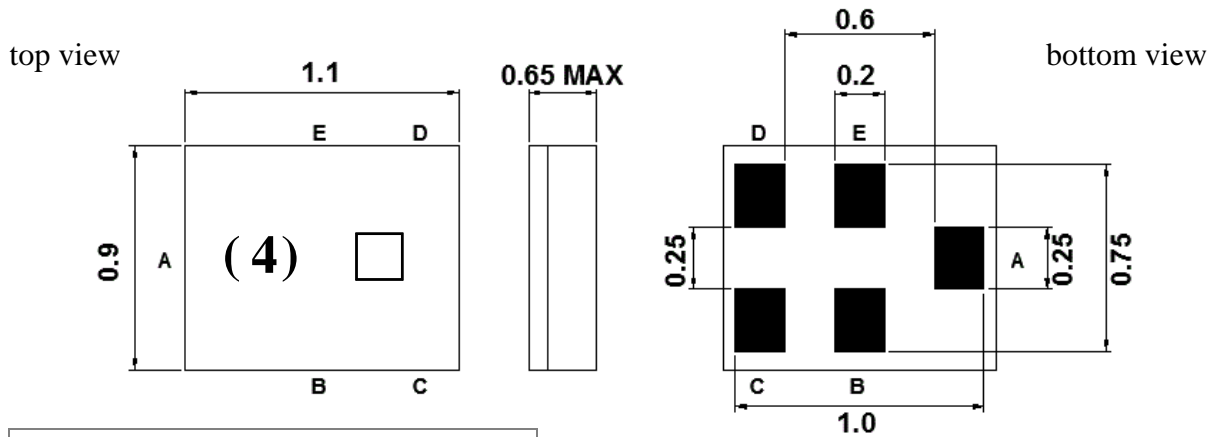

Marking Descriptions	
( 4 )	Series Number
□	Date Code(Year+Month)

Pin Description	
B, C, E	Ground
A	Input
D	Output

□ : Year/Month Code (Follow the table)

YEAR/Month	1	2	3	4	5	6	7	8	9	10	11	12
2013	A	B	C	D	E	F	G	H	J	K	L	M
2014	N	P	Q	R	S	T	U	V	W	X	Y	Z
2015	a	b	c	d	e	f	g	h	j	k	l	m
2016	n	p	q	r	s	t	u	v	w	x	y	z
2017	<u>A</u>	<u>B</u>	<u>C</u>	<u>D</u>	<u>E</u>	<u>F</u>	<u>G</u>	<u>H</u>	<u>J</u>	<u>K</u>	<u>L</u>	<u>M</u>
2018	<u>N</u>	<u>P</u>	<u>Q</u>	<u>R</u>	<u>S</u>	<u>T</u>	<u>U</u>	<u>V</u>	<u>W</u>	<u>X</u>	<u>Y</u>	<u>Z</u>

### D. MEASUREMENT CIRCUIT:

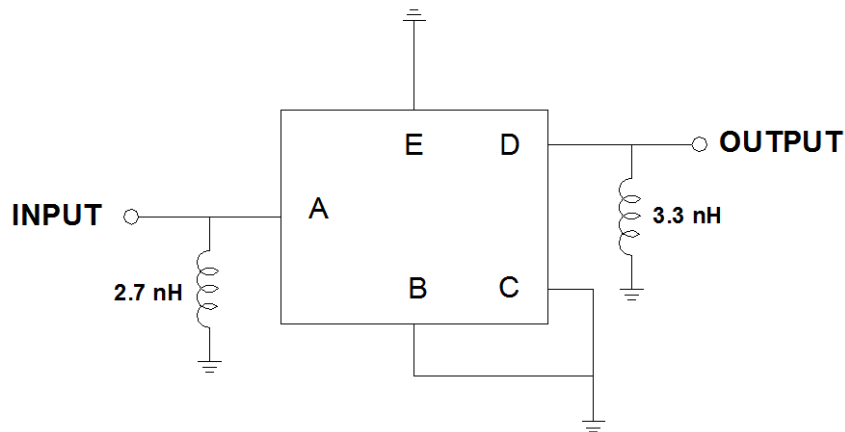

### E. PCB Footprint :

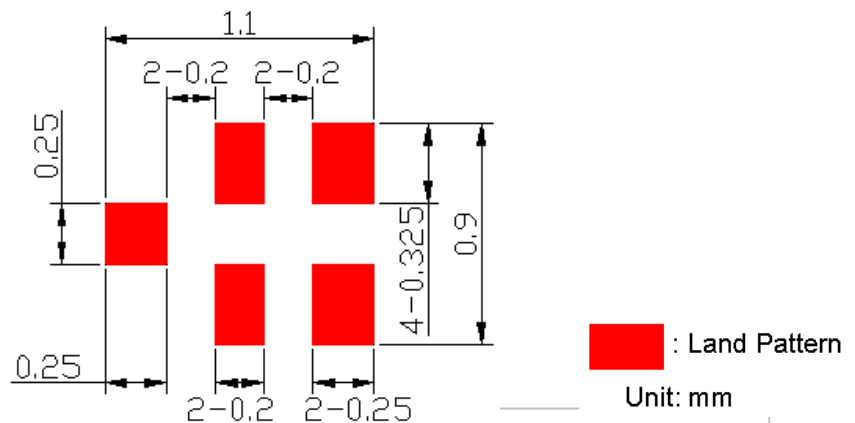

## F. Frequency Characteristics :

### Frequency Response

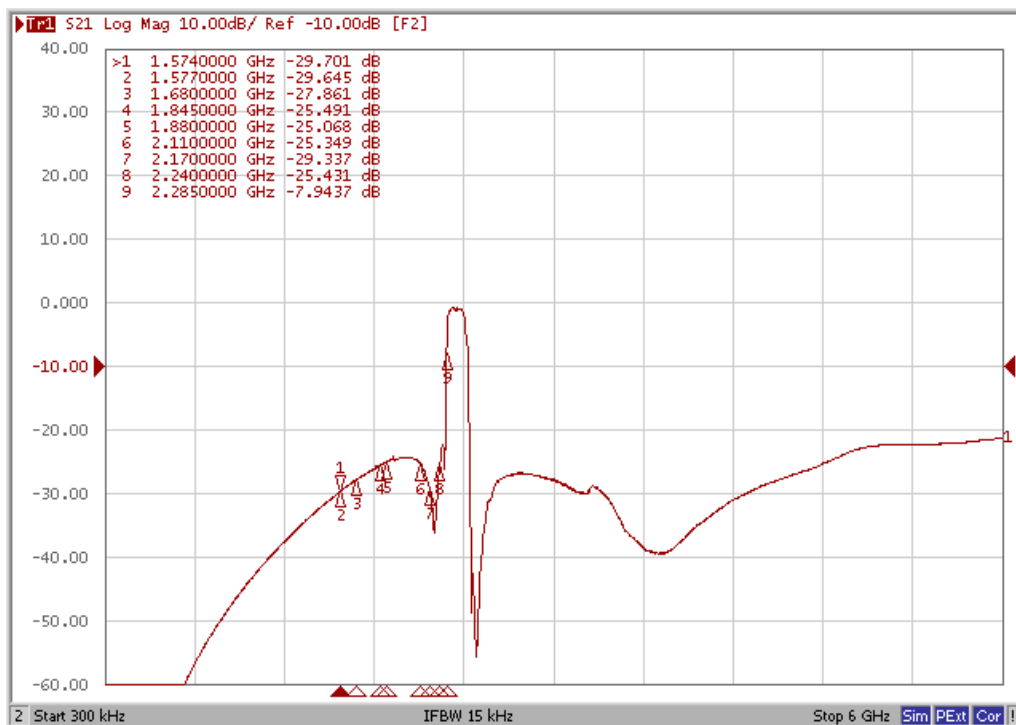
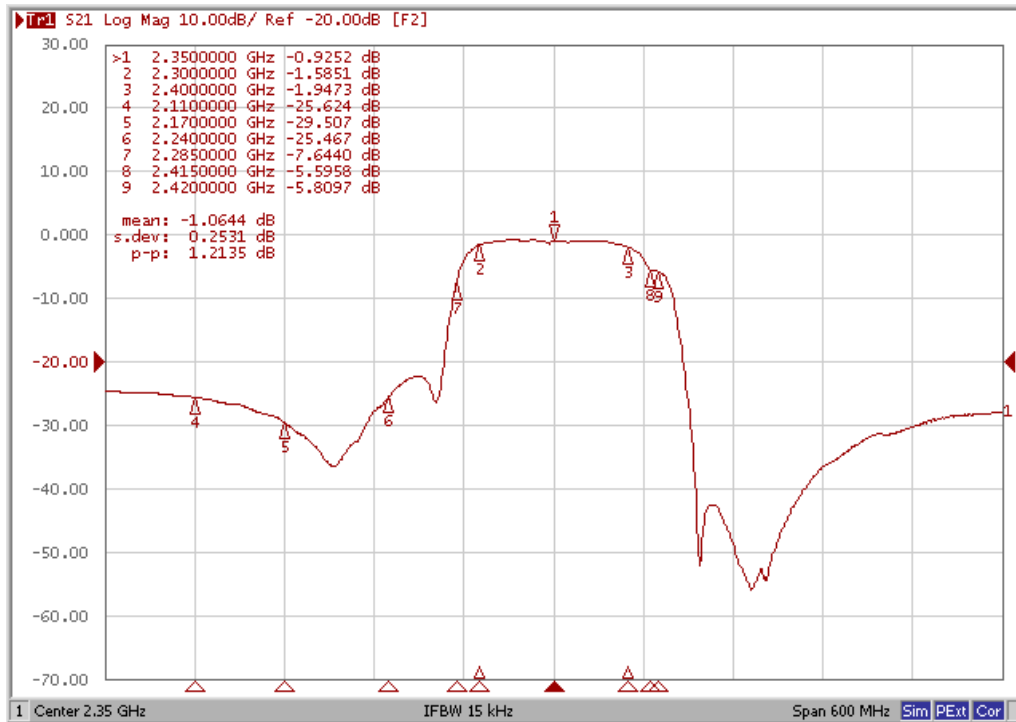

# Reflection Functions :

## VSWR

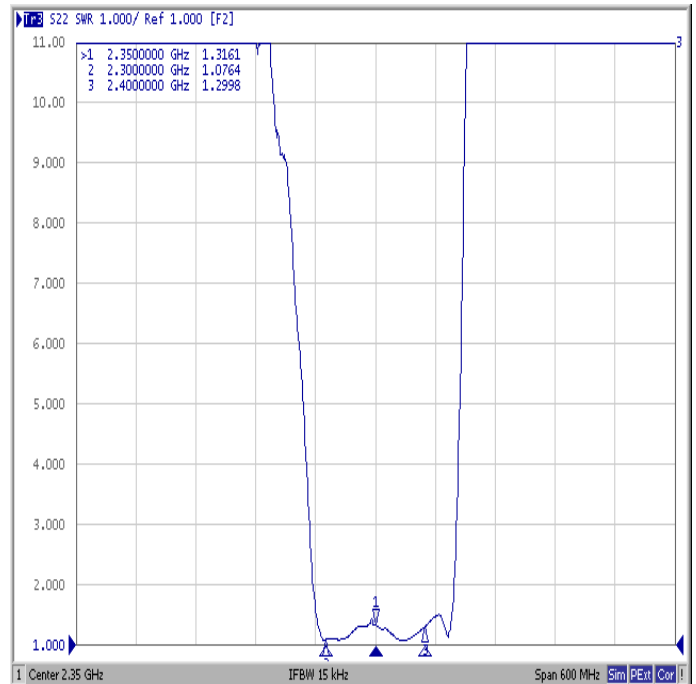
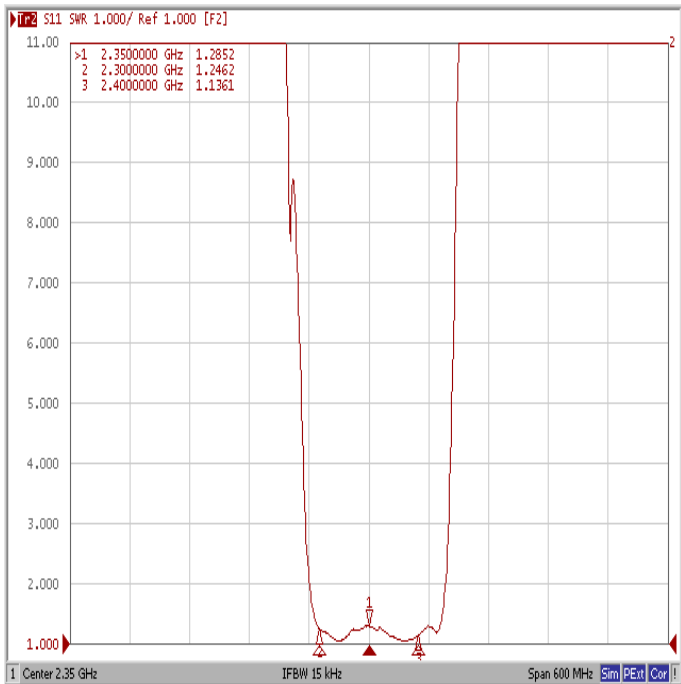

## Smith Chart

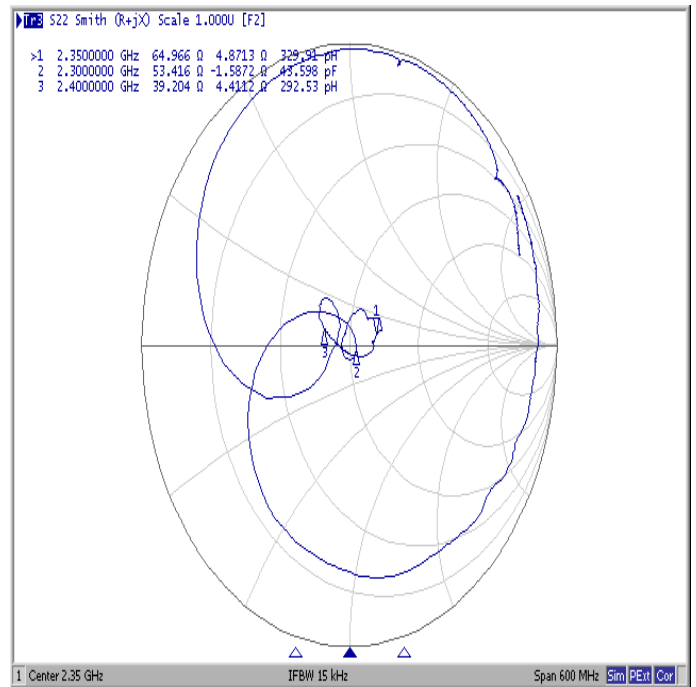
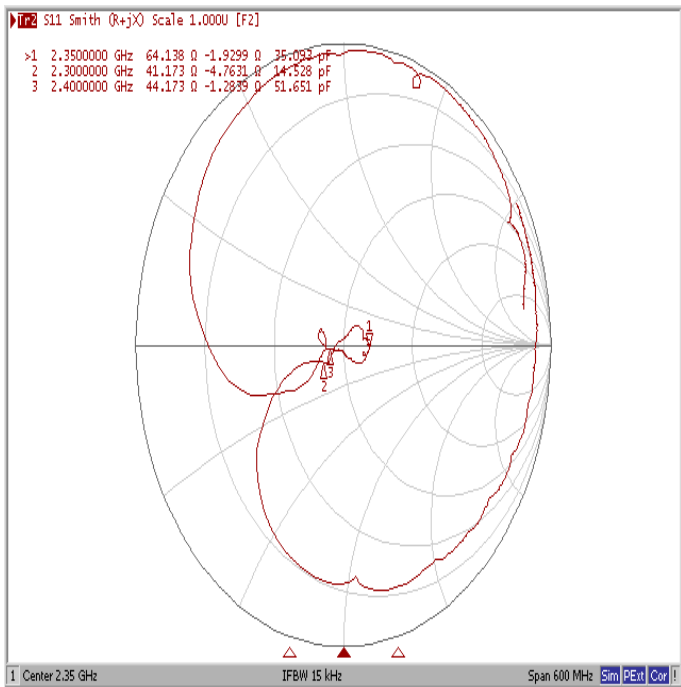

**G. PACKING:**

**1. REEL DIMENSION**

(Please refer to FR-75D10 for packing quantity)

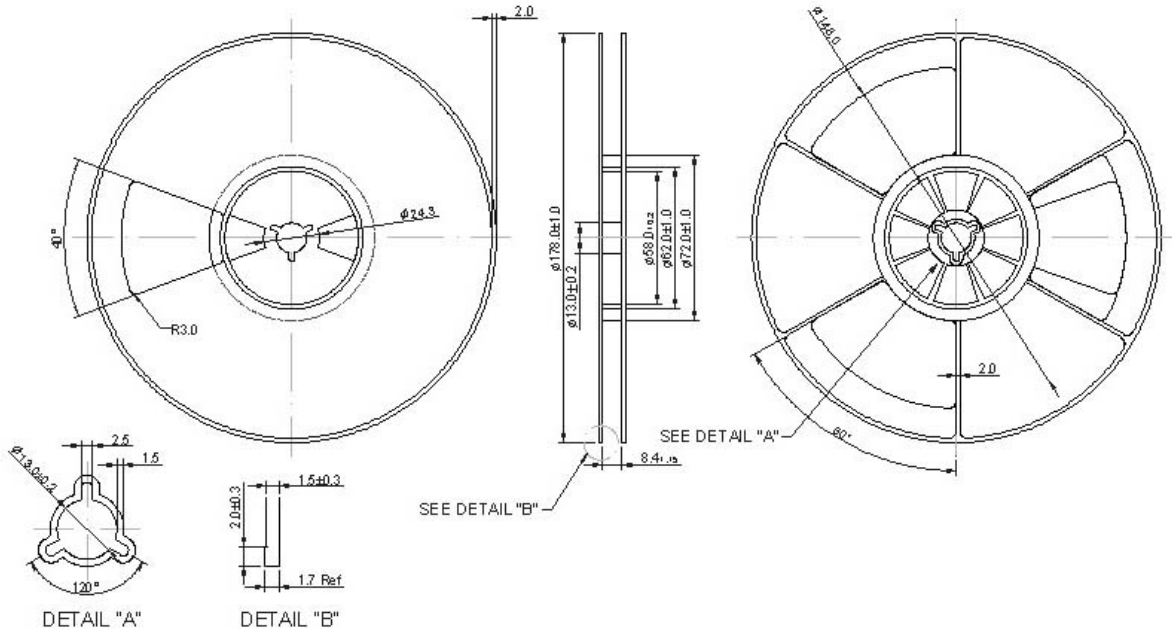

**2. TAPE DIMENSION**

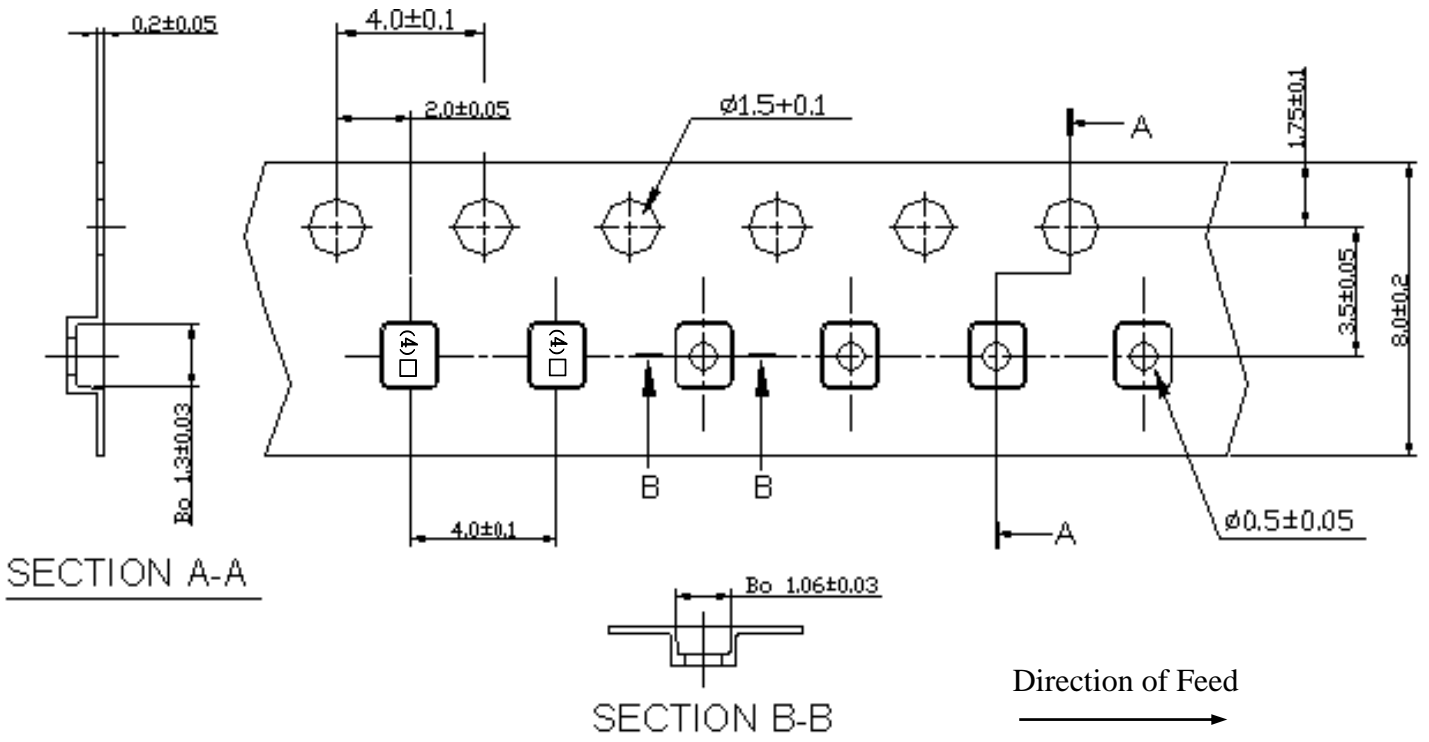

## H. RECOMMENDED REFLOW PROFILE :

1. Preheating shall be fixed at 150~180°C for 60~90 seconds.
2. Ascending time to preheating temperature 150°C shall be 30 seconds min.
3. Heating shall be fixed at 220°C for 50~80 seconds and at 260°C+0/-5°C peak (20~40sec).
4. Time: 2 times.

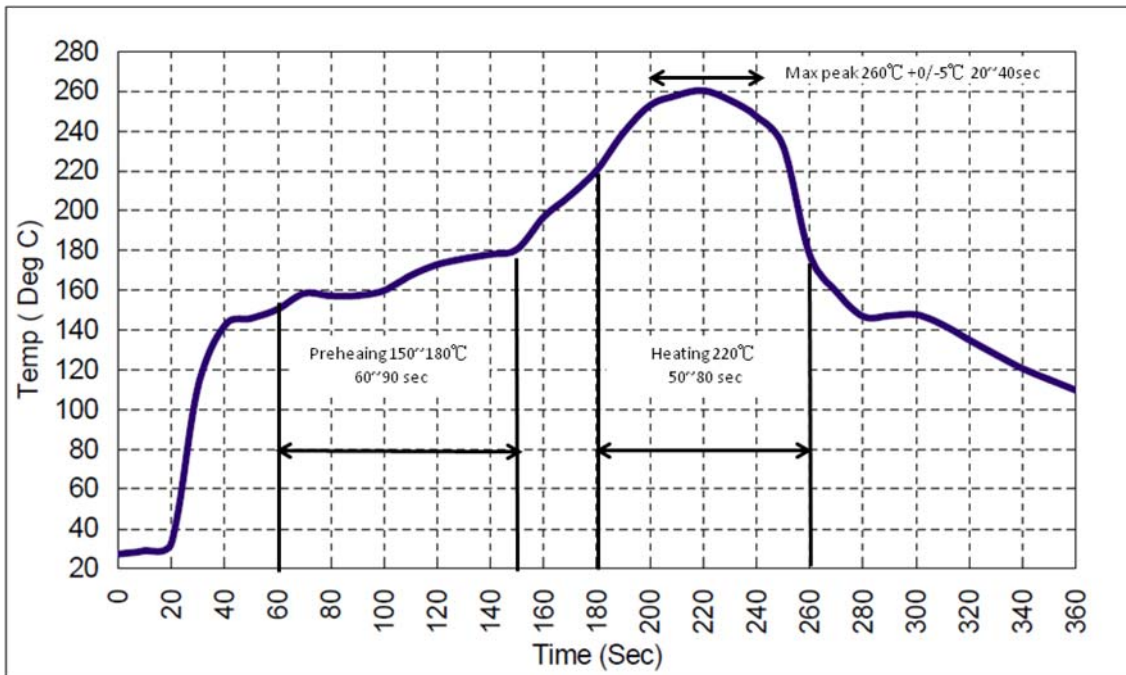

单击下面可查看定价，库存，交付和生命周期等信息

[>>TAI-SAW\(台湾嘉硕\)](#)