

Features

- V_{DS} -20V
- I_D -2.0A
- $R_{DS(ON)}$ (at $V_{GS}=-4.5V$) < 130 mohm
- $R_{DS(ON)}$ (at $V_{GS}=-2.5V$) < 170 mohm
- $R_{DS(ON)}$ (at $V_{GS}=-1.8V$) < 250 mohm

Applications

- Battery protection
- Load switch
- Power management



SOT323

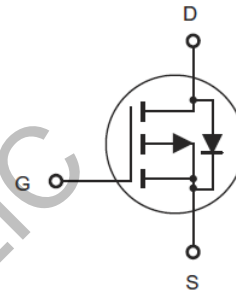

Absolute Maximum Ratings ($T_A=25^\circ\text{C}$ unless otherwise specified)

Parameter	Symbol	Maximum	Unit
Drain-source Voltage	V_{DS}	-20	V
Gate-source Voltage	V_{GS}	± 10	V
Drain Current	$T_A=25^\circ\text{C}$ @ Steady State	-2.0	A
	$T_A=70^\circ\text{C}$ @ Steady State	-1.6	
Pulsed Drain Current ^A	I_{DM}	-8	A
Total Power Dissipation @ $T_A=25^\circ\text{C}$	P_D	0.45	W
Thermal Resistance Junction-to-Ambient ^B	$R_{\theta JA}$	278	$^\circ\text{C}/\text{W}$
Junction and Storage Temperature Range	T_J, T_{STG}	-55~+150	$^\circ\text{C}$

Electrical Characteristics (T =25°C unless otherwise specified)

Parameter	Symbol	Conditions	Min	Typ	Max	Units
Static Parameter						
Drain-Source Breakdown Voltage	BV_{DSS}	$V_{GS}=0V, I_D=-250\mu A$	-20			V
Zero Gate Voltage Drain Current	I_{DSS}	$V_{DS}=-20V, V_{GS}=0V, T_C=25^\circ C$			-1	μA
Gate-Body Leakage Current	I_{GSS}	$V_{GS}= \pm 10V, V_{DS}=0V$			± 100	nA
Gate Threshold Voltage	$V_{GS(th)}$	$V_{DS}=V_{GS}, I_D=-250\mu A$	-0.4	-0.62	-1.0	V
Static Drain-Source On-Resistance	$R_{DS(on)}$	$V_{GS}= -4.5V, I_D=-1.5A$		100	130	m Ω
		$V_{GS}= -2.5V, I_D=-1.2A$		130	170	
		$V_{GS}= -1.8V, I_D=-1.0A$		165	250	
Diode Forward Voltage	V_{SD}	$I_S=-2.0A, V_{GS}=0V$		-0.8	-1.2	V
Maximum Body-Diode Continuous Current	I_S				-2.0	A
Dynamic Parameters						
Input Capacitance	C_{iss}	$V_{DS}=-10V, V_{GS}=0V, f=1MHz$		290		pF
Output Capacitance	C_{oss}			47		
Reverse Transfer Capacitance	C_{rss}			29		
Switching Parameters						
Total Gate Charge	Q_g	$V_{GS}=-4.5V, V_{DS}=-10V, I_D=-1.0A$		3.9		nC
Gate Source Charge	Q_{gs}			0.7		
Gate Drain Charge	Q_{gd}			0.9		
Turn-on Delay Time	$t_{D(on)}$	$V_{GS}=-4.5V, V_{DD}=-10V, I_D=-1A, R_{GEN}=2.5\Omega$		12		ns
Turn-on Rise Time	t_r			54		
Turn-off Delay Time	$t_{D(off)}$			15		
Turn-off Fall Time	t_f			9		

Outline Drawing - SOT323

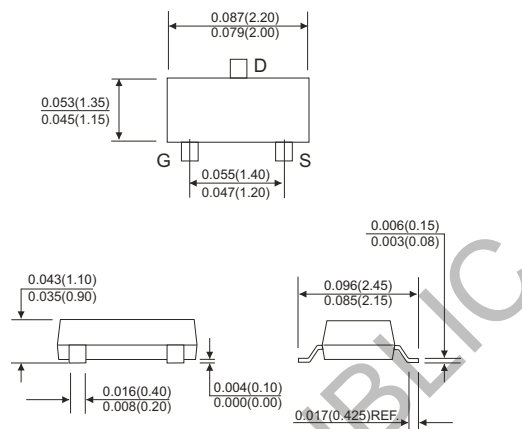

单击下面可查看定价，库存，交付和生命周期等信息

[>>TECH PUBLIC\(台舟\)](#)