

Features

- 2.0A Output Current
- 0.6V Reference
- High Efficiency: Up to 95%
- No Schottky Diode Required
- 600KHz Frequency Operation
- Over Current Protection with Hiccup-Mode
- 3.5V to 18V Input Voltage Range
- Integrated internal compensation
- Input over voltage protection(OVP)
- Inrush Current Limit and Soft Start
- Stable with Low ESR Ceramic Output Capacitors

Applications

- Notebook Computer
- Digital Set Top Boxes
- Wireless and DSL Modems
- Distributed Power Systems
- Flat Panel Television and Monitors

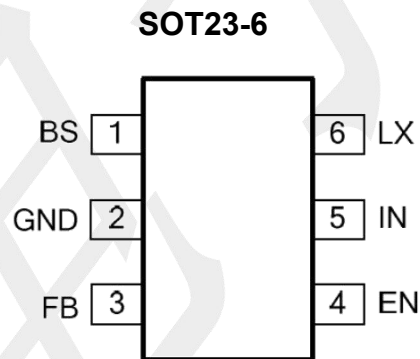

PIN CONFIGURATION

PIN	NAME	FUNCTION
1	BS	Bootstrap. A capacitor connected between LX and BST pins is required to form a floating supply across the high-side switch driver.
2	GND	Ground
3	FB	Adjustable version feedback input. Connect FB to the center point of the external resistor divider.
4	EN	Drive this pin to a logic-high to enable the IC. Drive to a logic-low to disable the IC and enter micro-power shutdown mode.
5	IN	Power supply Pin
6	LX	Switching Pin

Absolute Maximum Ratings

over operating free-air temperature range (unless otherwise noted)

Parameter		MIN	MAX	UNIT
EN	Continuous input voltage range	-0.3	23	V
LX	Continuous input voltage range	-0.3	23	V
FB	Continuous input voltage range	-0.3	6	V
BS	Continuous input voltage range	-0.3	25	V
Operating Junction Temperature Range T _J		-40	125	°C
Storage Temperature Range T _{stg}		-55	150	°C
Lead Temperature (Soldering, 10s)		260		°C
Power Dissipation		600		mW

BLOCK DIAGRAM

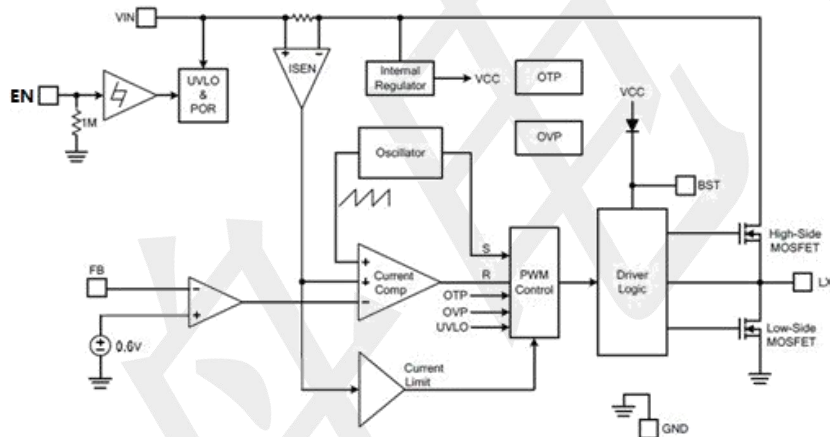

Typical Application Circuit

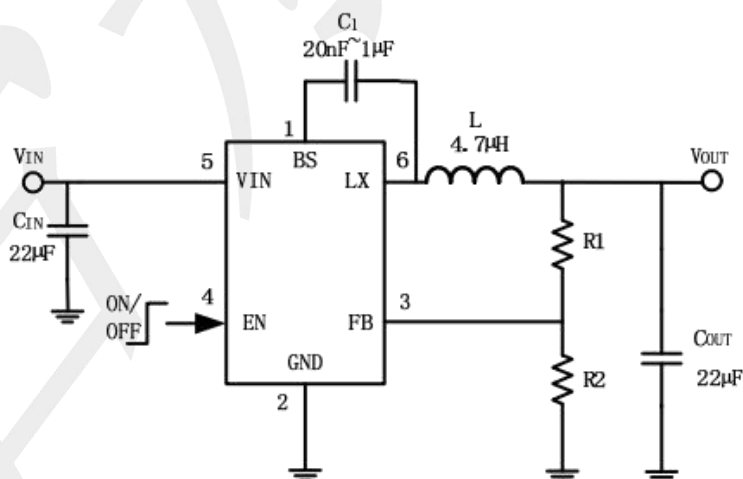

Electrical Characteristics (VIN=12V, VOUT=5V, TA=25°C, unless otherwise specified)

PARAMETER	TEST Conditions	MIN	TYP	MAX	UNIT
Input Voltage Range		3.5	--	18	V
OVP Threshold		--	19	--	V
UVLO Threshold		3.0	--	--	V
Supply Current in Operation	VEN=2.0V, VFB=1.1V	--	0.4	0.6	mA
Supply Current in Shutdown	VEN=0 or EN=GND	--	1	--	uA
Regulated Feedback Voltage	TA = 25°C, 3.5V ≤ VIN ≤ 18V	0.58	0.6	0.61	V
High - Side Switch On - Resistance		--	120	--	mΩ
Low - Side Switch On - Resistance		--	80	--	mΩ
High - Side Switch Leakage Current	VEN=0V, VLX=0V	0	--	10	uA
Upper Switch Current Limit	Minimum Duty Cycle	2.5	--	--	A
Oscillation Frequency	VFB=0.6V	--	600	--	KHZ
Maximum Duty Cycle		--	95	--	%
EN High Level Input Threshold		1.5	--	--	V
EN Low Level Input Threshold		--	0.3	--	V
Minimum On - Time		--	60	--	nS
Thermal Shutdown		--	160	--	°C

Note: TJ is calculated from the ambient temperature TA and power dissipation PD according to the following formula: TJ = TA + (PD) x (250°C/W). 100% production test at +25°C. Specifications over the temperature range are guaranteed by design and characterization.

APPLICATION INFORMATION

Setting the Output Voltage

The external resistor divider is used to set the output voltage (see Typical Application on page 1). The feedback resistor R1 also sets the feedback loop bandwidth with the internal compensation capacitor. Choose R1 to be around 51kΩ for optimal transient response. R2 is then given by:

Vout	R1(kΩ)	R2(kΩ)
5.1V	51	6.8
3.3V	51	11.3
1.8V	51	25.5
1.55V	51	33
1.25V	51	47
1.20V	51	51
1.05V	33	47

$$R_2 = \frac{R_1}{V_{out}/V_{FB} - 1}$$

Inductor Selection

A 1μH to 4.7μH inductor with a DC current rating of at least 25% percent higher than the maximum load current is recommended for most applications. For highest efficiency, the inductor DC resistance should be less than 15mΩ. For most designs, the inductance value can be derived from the following equation.

$$L = \frac{V_{out} \times (V_{in} - V_{out})}{V_{in} \times \Delta I_L \times f_{OSC}}$$

Where ΔIL is the inductor ripple current. Choose inductor ripple current to be approximately 30% if the maximum load current, 2A. The maximum inductor peak current is:

$$I_{L(MAX)} = I_{LOAD} + \frac{\Delta I_L}{2}$$

Under light load conditions below 100mA, larger inductance is recommended for improved efficiency.

Output Capacitor Selection

The output capacitor (C2) is required to maintain the DC output voltage. Ceramic, tantalum, or low ESR electrolytic capacitors are recommended. Low ESR capacitors are preferred to keep the output voltage ripple low. The output voltage ripple can be estimated by:

$$\Delta V_{OUT} = \frac{V_{OUT}}{f_S \times L} \times \left[1 - \frac{V_{OUT}}{V_{IN}} \right] \times \left[R_{ESR} + \frac{1}{8 \times f_S \times C_2} \right]$$

Where L is the inductor value and RESR is the equivalent series resistance (ESR) value of the output capacitor. In the case of ceramic capacitors, the impedance at the switching frequency is dominated by the capacitance. The output voltage ripple is mainly caused by the capacitance. For simplification, the output voltage ripple can be estimated by:

$$\Delta V_{OUT} = \frac{V_{OUT}}{8 \times f_S^2 \times L \times C_2} \times \left[1 - \frac{V_{OUT}}{V_{IN}} \right]$$

In the case of tantalum or electrolytic capacitors, the ESR dominates the impedance at the switching frequency. For simplification, the output ripple can be approximated to:

$$\Delta V_{OUT} = \frac{V_{OUT}}{f_S \times L} \times \left[1 - \frac{V_{OUT}}{V_{IN}} \right] \times R_{ESR}$$

The characteristics of the output capacitor also affect the stability of the regulation system. The can be optimized for a wide range of capacitance and ESR values.

Package information

SOT23-6

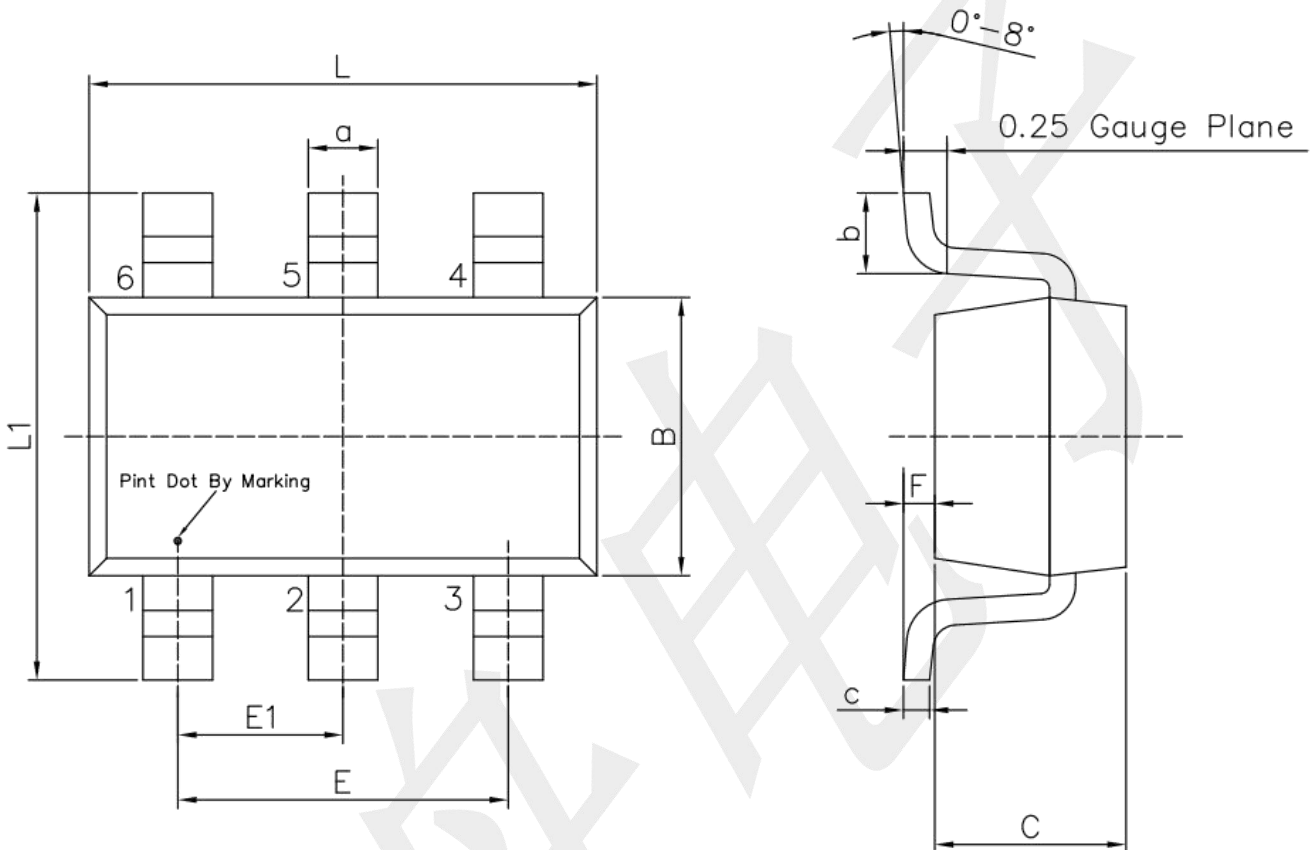

Unit: mm

Symbol	Dimensions In Millimeters		Symbol	Dimensions In Millimeters	
	Min	Max		Min	Max
L	2.82	3.02	E1	0.85	1.05
B	1.50	1.70	a	0.35	0.50
C	0.90	1.30	c	0.10	0.20
L1	2.60	3.00	b	0.35	0.55
E	1.80	2.00	F	0	0.15

单击下面可查看定价，库存，交付和生命周期等信息

[>>TECH PUBLIC\(台舟\)](#)