

REVISIONS					
P	LTR	DESCRIPTION	DATE	DMN	APVD
G		REVISED PER ECO-17-018523	19JAN2018	PHM	CT

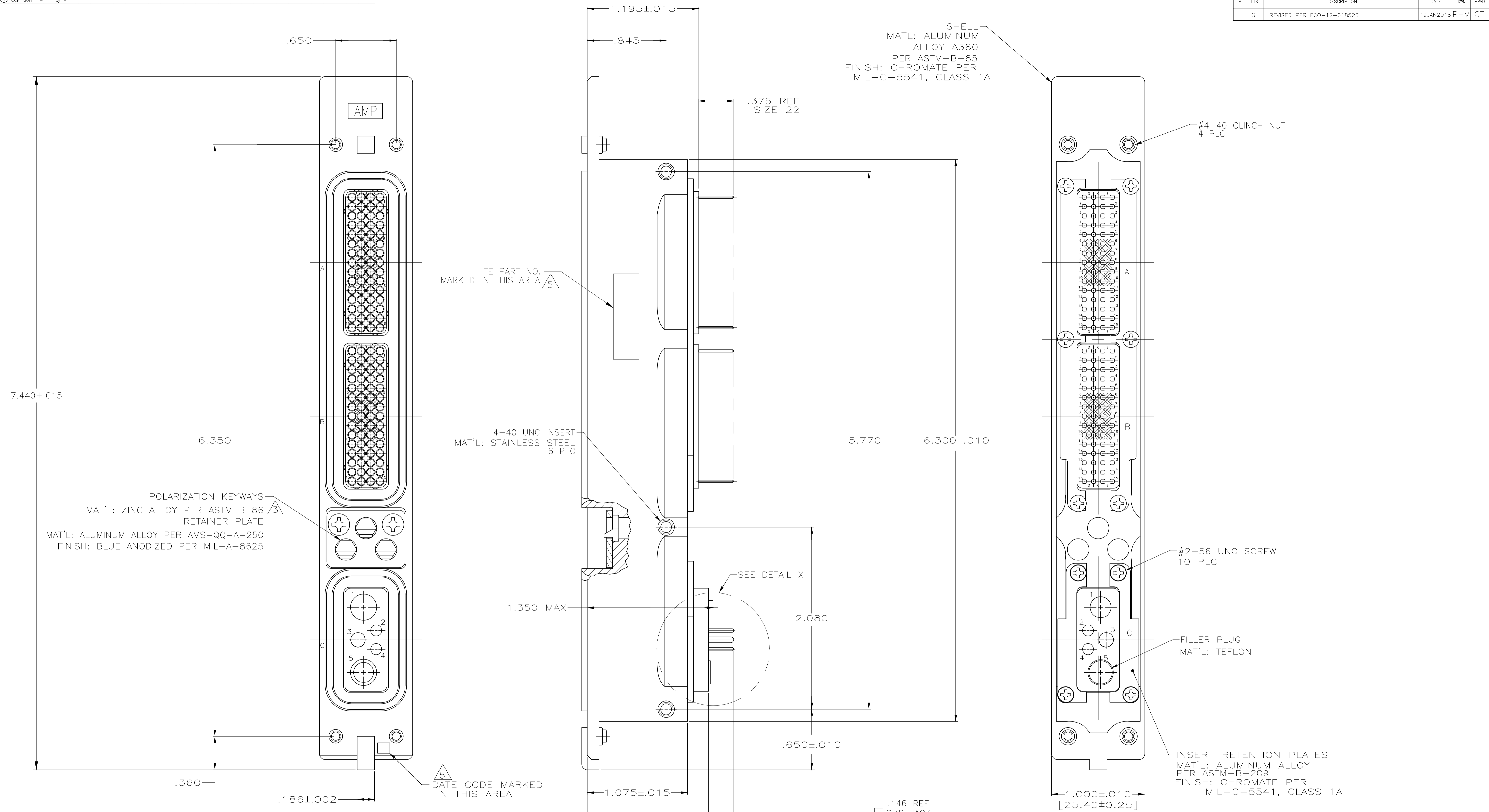

- CONNECTOR DIMENSIONS ARE PER ARINC 600 SPECIFICATION
- FOLLOWING CONTACTS ARE INCLUDED AND LOADED:  
 SIZE 22 SOCKET: AMP P/N 1-211431-4; QTY: 120  
 SIZE 16 PIN (POSTED): 1663128-6; QTY: 2  
 SIZE 12 PIN (POSTED): 1663129-6; QTY: 1  
 SIZE 5 FILLER PLUG: 1663132-1; QTY: 1  
 SIZE 5 SMB: P/N 1663389-2; QTY: 1  
 ALL SOLDER POSTS ARE SOLDER DIPPED.

- KEYING SHOWN IN POSITION "01" FOR REFERENCE ONLY. SEE TABLE FOR KEYING POSITION. FOR POSITION "00" KEYING SHIPPED UNASSEMBLED.
- CONTACTS NOT SHOWN IN FRONT AND REAR VIEWS FOR CLARITY.
- DATE CODE MAY BE LOCATED UNDER PART NUMBER.

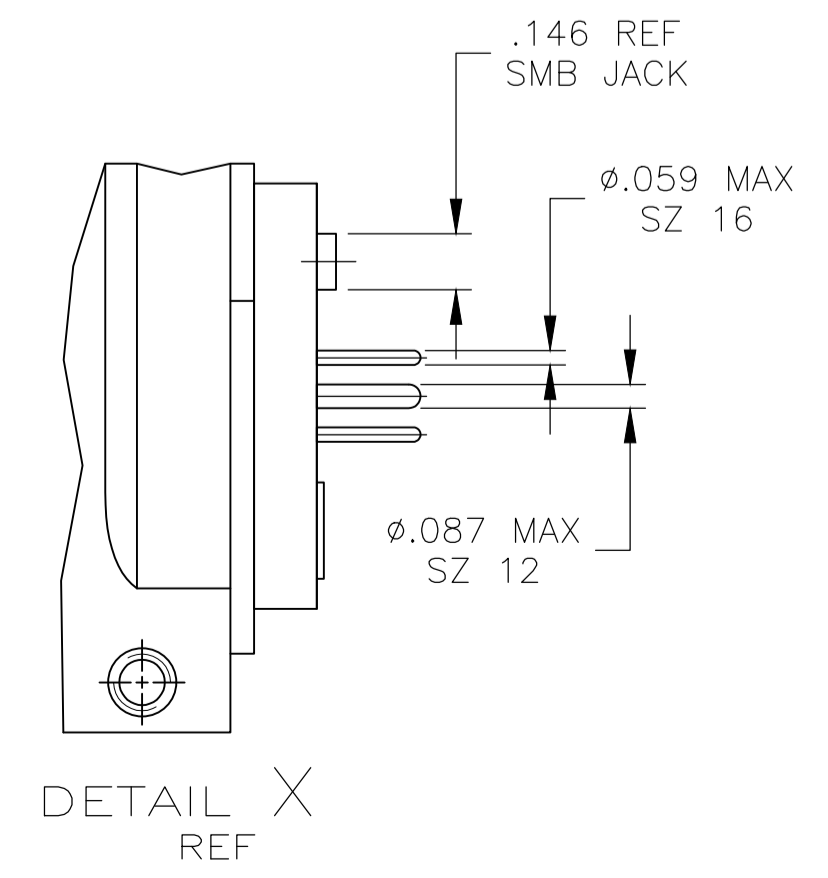

"10"	1757056-1
KEYING POSITION	PART NUMBER

THIS DRAWING IS A CONTROLLED DOCUMENT.		DMN C.C.THOMAS 3-2-04	RESTRICTED TO	
DIMENSIONS: INCHES		CHK S.GLATFELTER 3-2-04	NAME	
TOLERANCES UNLESS OTHERWISE SPECIFIED:		APVD S.GLATFELTER 3-2-04	PRODUCT SPEC	
0 PLC ± -		APPLICATION SPEC		
1 PLC ± -		WEIGHT		
2 PLC ± -		A1 00779 1757056		
3 PLC ± .005		CUSTOMER DRAWING		
4 PLC ± -		SCALE 2:1 SHEET 1 OF 1 REV G		
ANGLES ± -				
FINISH SEE CALLOUTS				



TE Connectivity

RECEPTACLE ASSY, SIZE 1, ARINC 600 (60/60/5C2)

单击下面可查看定价，库存，交付和生命周期等信息

[>>TE Connectivity\(泰科\)](#)