

THIS DRAWING IS UNPUBLISHED. RELEASED FOR PUBLICATION
 © COPYRIGHT BY TYCO ELECTRONICS CORPORATION. ALL RIGHTS RESERVED.

LOC		DIST		REVISIONS			
P	LTR	DESCRIPTION	DATE	DWN	APVD		
CM	0						
	D	REVISED PER 0G3B-0237-05	9/21/05	SS	CJ		

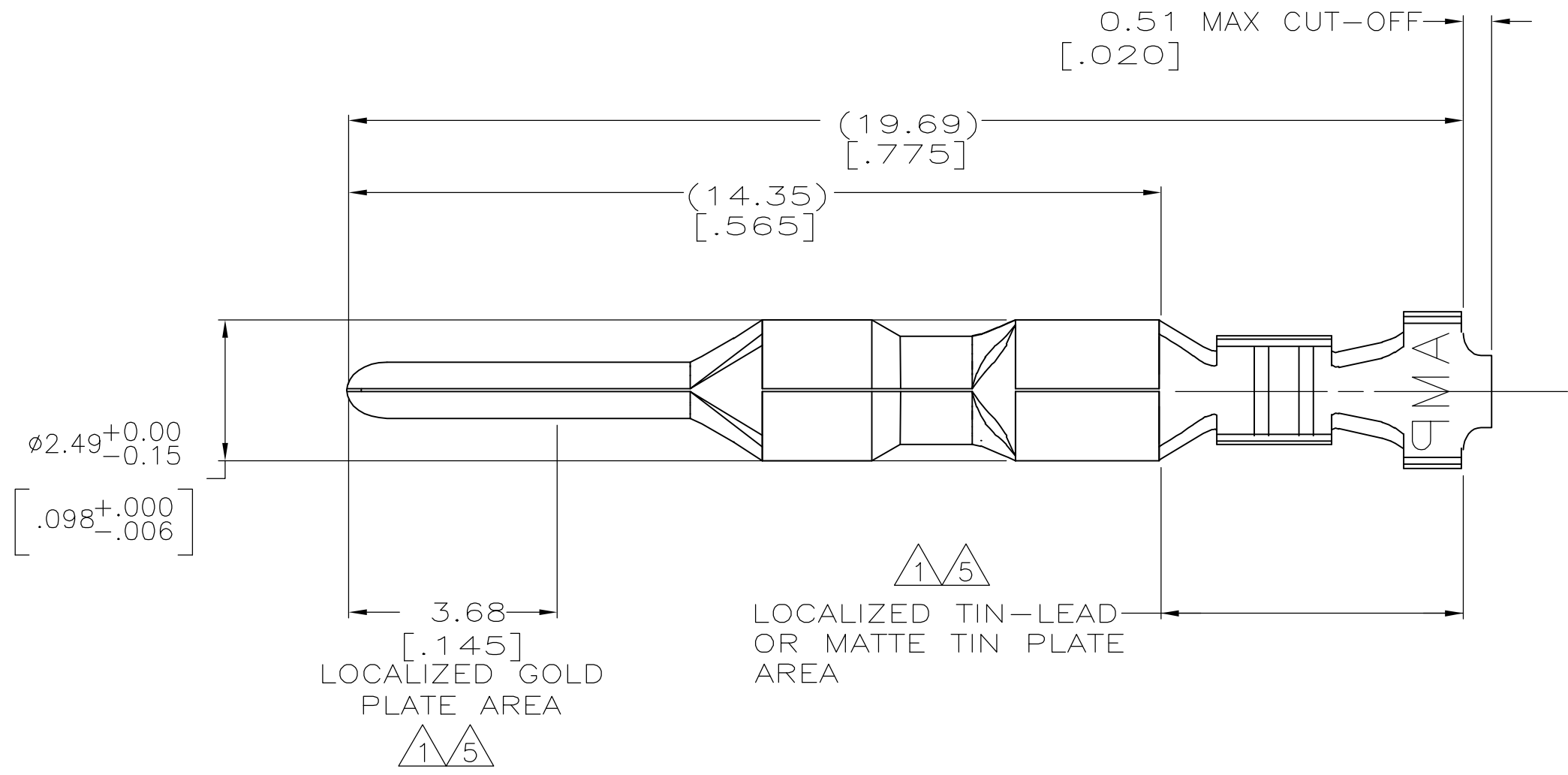

- 1. 0.00076 [.000030] MIN GOLD IN LOCALIZED GOLD PLATE AREA AND 0.00254 [.000100] MIN BRIGHT TIN-LEAD IN LOCALIZED TIN-LEAD PLATE AREA OVER 0.0013 [.000050] MIN NICKEL.
- 2. WIRE RANGE: 0.12 - 0.4MM² (26-22 AWG).
- 3. INSULATION RANGE: 1.19-1.75 [.047-.069] DIA.
- 4. DIMENSIONS IN BRACKETS ARE IN INCHES.
- 5. 0.00076 [.000030] MIN GOLD IN LOCALIZED GOLD PLATE AREA AND 0.00254 [.000100] MIN MATTE TIN IN LOCALIZED TIN PLATE AREA OVER 0.0013 [.000050] MIN NICKEL.

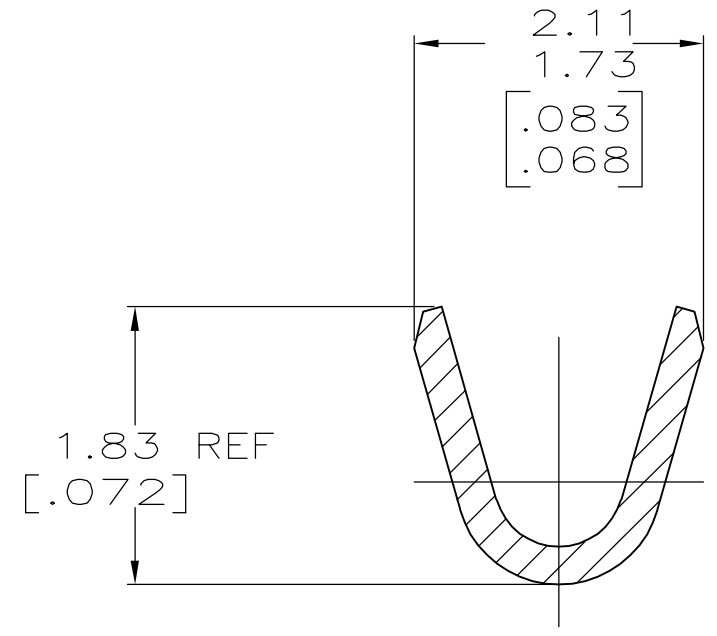
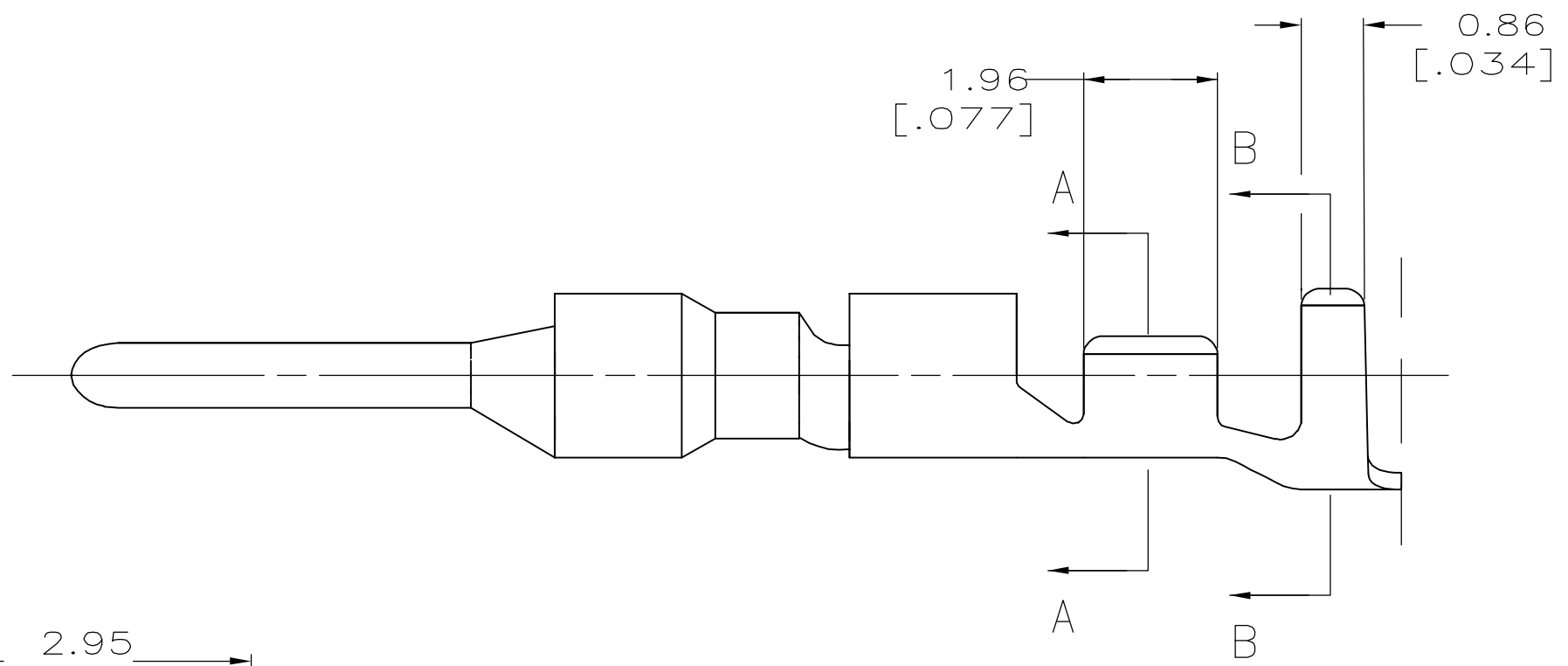

SECTION A-A
SCALE 20:1

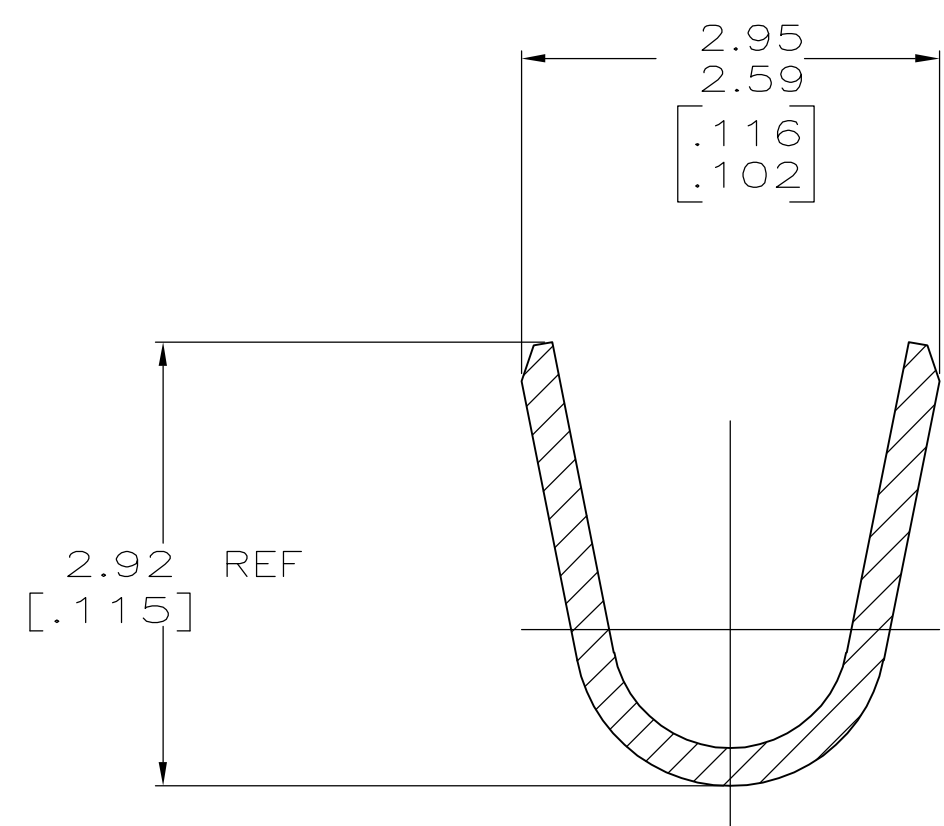

SECTION B-B
SCALE 20:1

5	0.25 [.010] BRASS	1-794226-0
1	0.25 [.010] BRASS	794226-3
PRE-TIN	0.25 [.010] BRASS	794226-1
FINISH	MATERIAL	PART NUMBER

THIS DRAWING IS A CONTROLLED DOCUMENT.		DWN R. VESTAL 1-15-97	Tyco Electronics Corporation Harrisburg, PA 17105-3608	
DIMENSIONS: mm [INCHES]		CHK R. SWING 1-15-97		
TOLERANCES UNLESS OTHERWISE SPECIFIED:		APVD -	NAME PIN, LOOSE PIECE, MINI UNIVERSAL MATE-N-LOK 2	
0 PLC ± -		PRODUCT SPEC -	SIZE A2	
1 PLC ± -		APPLICATION SPEC -	CAGE CODE 00779	DRAWING NO C=794226
2 PLC ± -		WEIGHT -	RESTRICTED TO -	
3 PLC ± 0.15 [.006]		SCALE 10:1		
4 PLC ± -		SHEET 1 of 1		
ANGLES ± -		REV D		
FINISH SEE TABLE		CUSTOMER DRAWING		

单击下面可查看定价，库存，交付和生命周期等信息

[>>TE Connectivity\(泰科\)](#)