

THIS DRAWING IS UNPUBLISHED. RELEASED FOR PUBLICATION
 © COPYRIGHT - By - ALL RIGHTS RESERVED.

REVISIONS					
P	LTR	DESCRIPTION	DATE	DWN	APVD
	V	REVISED PER ECO-16-012447	26SEPT16	RS	DH

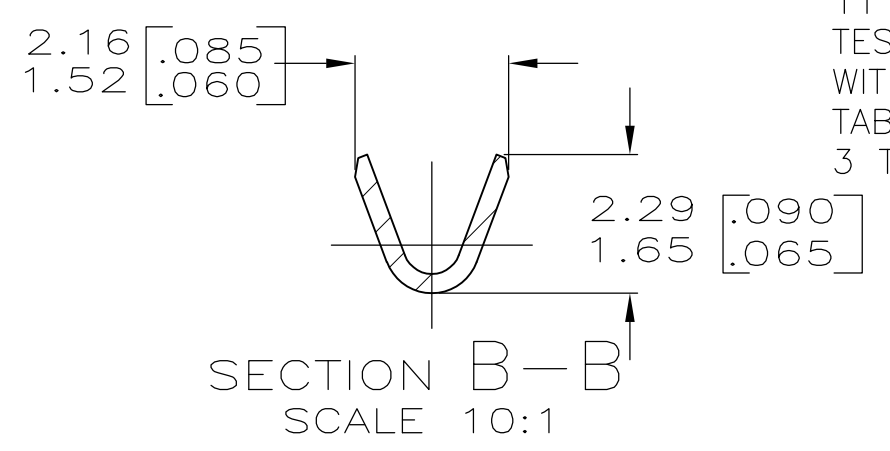

- 1 CONTINUOUS STRIP ON REELS.
- 2 FEED IS 8.89±0.13 [.350±.005]
- △3 TIN PLATE 0.002032 [.000080] MIN.
- △4 GOLD PLATE 0.000381 [.000015] MIN OVER 0.000762 [.000030] MIN THK NICKEL.
- △5 GOLD PLATE REQUIRED IN THIS AREA ONLY.
- △6 REVERSE REELING.
- 7 MAX TEST TAB MUST ENTER & WITHDRAW FROM RECPT. WITH A MAX FORCE OF 11 LBS. (USE GAGE 100716-40). MIN TEST TAB MUST WITHDRAW FROM RECPT WITH MIN PULL OF 1 LB AFTER MAX TAB HAS BEEN INSERTED & WITHDRAWN 3 TIMES.

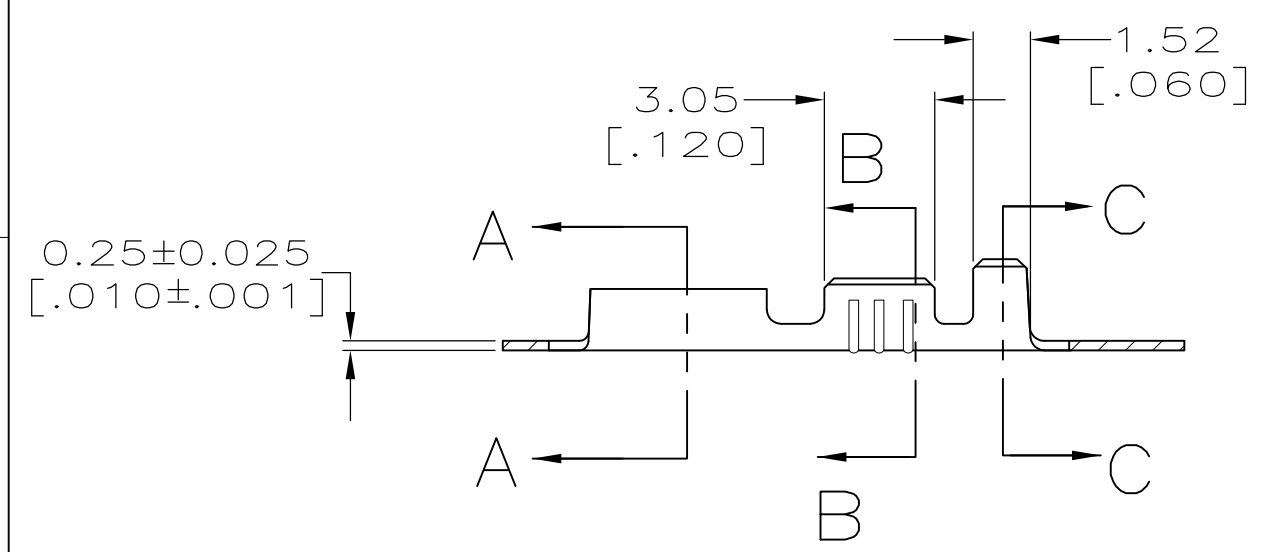
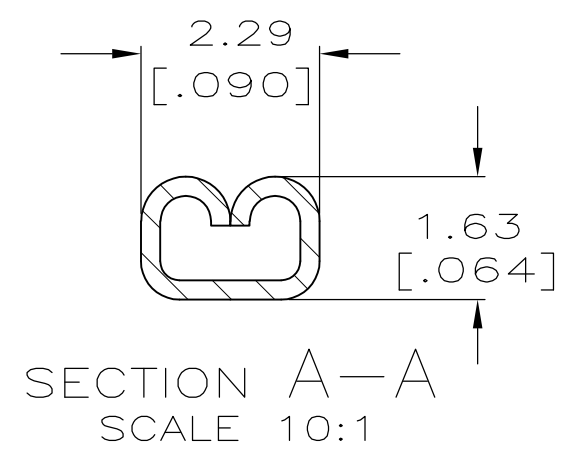
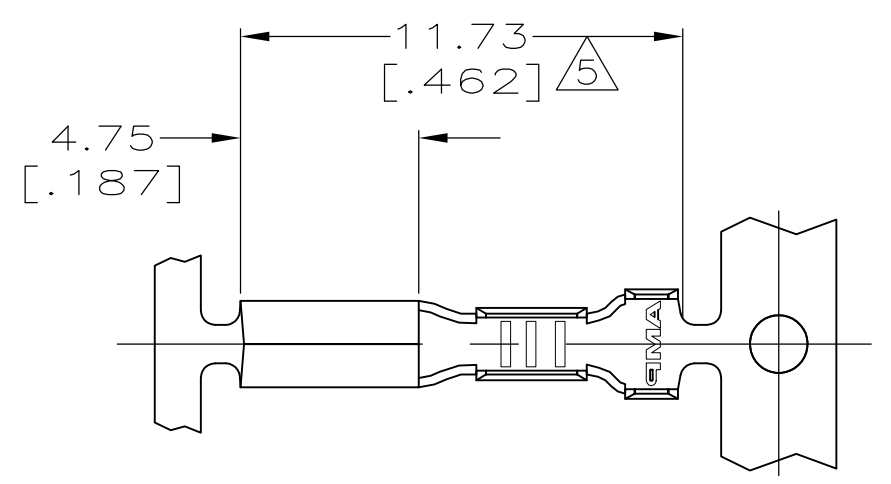
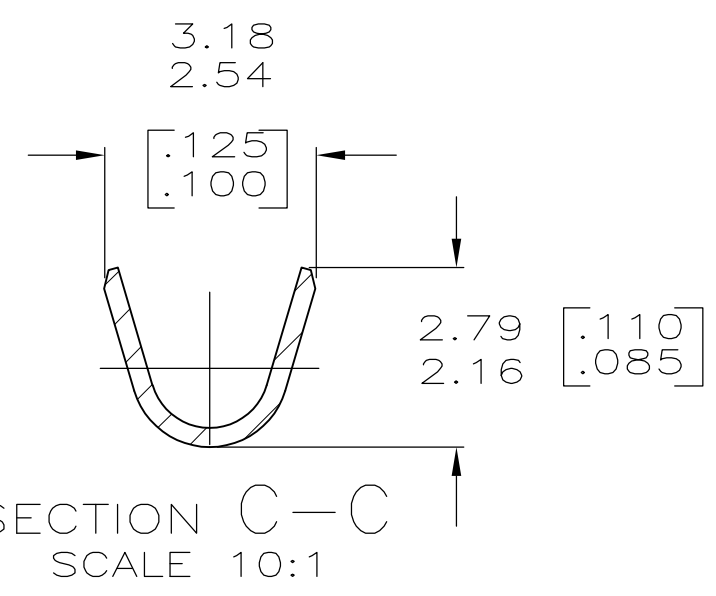

FINISH	INSULATION RANGE	WIRE SIZE	MATING TAB THK	PART NO.
△6 OBSOLETE	GOLD △4	1.02-2.03 DIA [.040-.080] DIA	[#24-#22] AWG	±0.025 0.79 X 1.58 60900-5-
△6 △3	TIN			±.001 [.031 X .062] 60900-4
OBSOLETE	GOLD △4			60900-3
OBSOLETE	△3 TIN			60900-2-
				60900-1-

THIS DRAWING IS A CONTROLLED DOCUMENT.		DWN JR RUTH 1/24/95	STE TE Connectivity		
		CHK MS FEHER 1/24/95			
DIMENSIONS: mm [INCHES]		APVD R REINER 1/24/95	NAME		
TOLERANCES UNLESS OTHERWISE SPECIFIED: 0 PLC ± - 1 PLC ± - 2 PLC ± 0.25 [.010] 3 PLC ± - 4 PLC ± - ANGLES ± -		PRODUCT SPEC	RECEPTACLE, TAB, WRAP TYPE		
MATERIAL BRASS		FINISH SEE TABLE	APPLICATION SPEC	SIZE A3	CAGE CODE 00779
		WEIGHT 0	DRAWING NO C-60900	RESTRICTED TO	
CUSTOMER DRAWING			SCALE 5:1	SHEET 1 OF 1	REV V

单击下面可查看定价，库存，交付和生命周期等信息

[>>TE Connectivity\(泰科\)](#)