

THIS DRAWING IS UNPUBLISHED. RELEASED FOR PUBLICATION 20
 © COPYRIGHT 20 BY TYCO ELECTRONICS CORPORATION. ALL RIGHTS RESERVED.

LOC	DIST	REVISIONS			
P	LTR	DESCRIPTION	DATE	DWN	APVD
GP	00	A	NEW RELEASE	24JUL2007	RG SF
		B	REV PER ECO-08-029221	3DEC08	RG DO

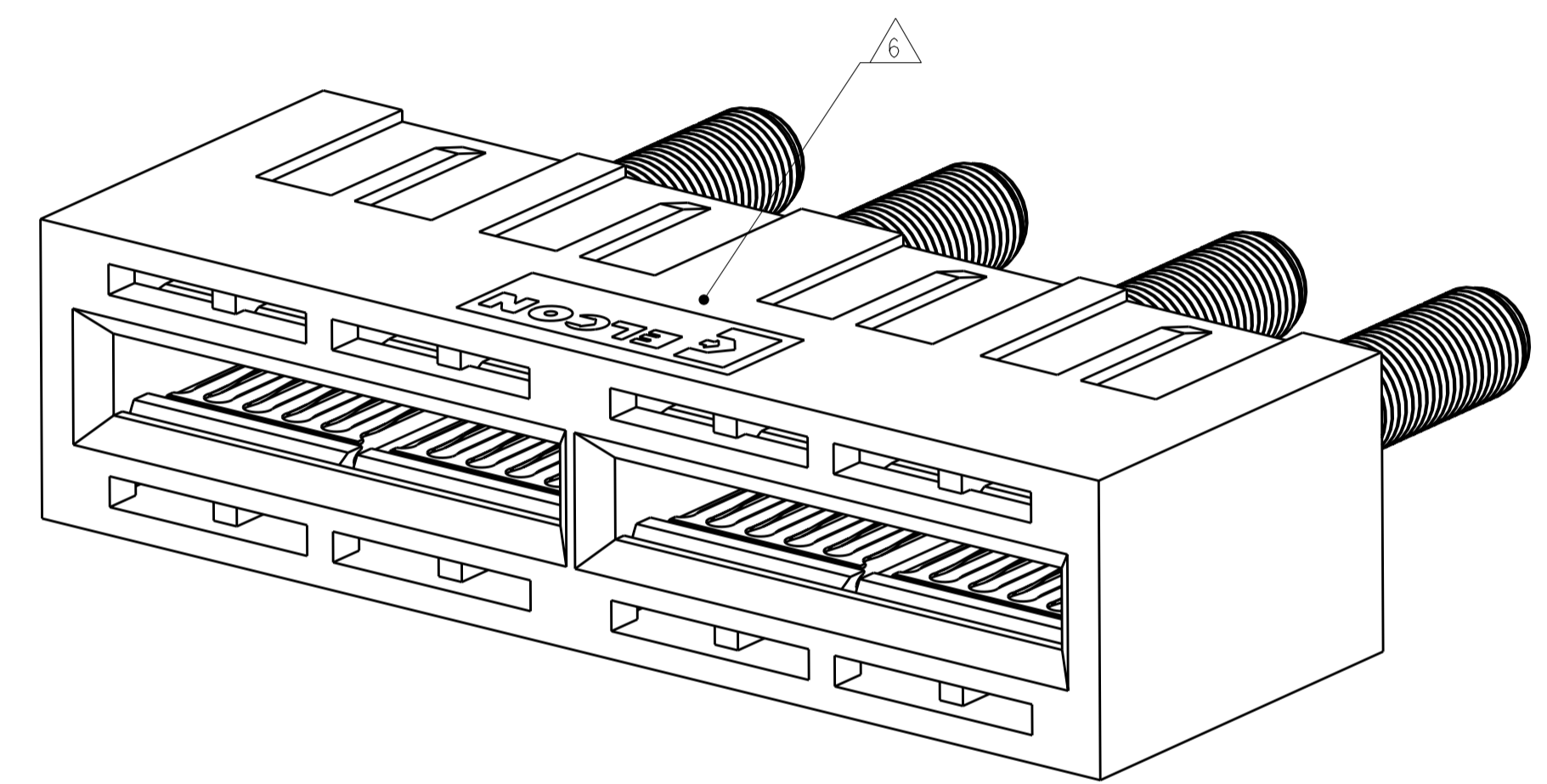

- PART NUMBER CHANGES AND OR DESIGN CHANGES AFFECTING ITEM INTERCHANGEABILITY REQUIRE PRIOR TYCO ELECTRONICS APPROVAL AND AUTHORIZATION BY REVISION TO THIS DRAWING.
- MATERIAL :
 INSULATORS - THERMOPLASTIC, GLASS REINFORCED UL RATED 94V-0 FLAMMABILITY RATED.
 BLADE CONTACTS - BERYLLIUM COPPER
 CONTACT HOLDER - COPPER ALLOY
- FINISH:
 CONTACT - GOLD PLATE 0.254µm MIN THK OVER
 NICKEL 1.27µm MIN THK
 CONTACT HOLDER - NICKEL 10µm MIN THK.
- OUTLINE SPECIFICATION:
 -2X PAIRED BLADE CONTACTS, 200 AMPS EACH PAIR, 250V
 -CONNECTOR GATHERABILITY: ±2.0, WHEN BLADE HAS LEAD CHAMFER
 -MATING FORCE: 221bf MAX.
 -STRAIGHT CONNECTOR CONFIGURATION, PRINTED CIRCUIT MOUNT, THREAD STUD WITH HEX NUT ATTACHMENT
 -NON-POLARIZED MOLDED INSULATOR
- A REFERENCE DIMENSION (X.XX) IS WITHOUT TOLERANCE AND USED FOR INFORMATION ONLY.

△ ITEMS PROVIDED TO THIS SPECIFICATION TO BE PERMANENTLY IDENTIFIED PER THE FOLLOWING IDENTIFIER LABEL:



AS SHOWN	1643904-1
DESCRIPTION	PART NO.

THIS DRAWING IS A CONTROLLED DOCUMENT FOR TYCO ELECTRONICS CORPORATION. IT IS SUBJECT TO CHANGE AND THE CONTROLLING ENGINEERING ORGANIZATION SHOULD BE CONTACTED FOR THE LATEST REVISION.		DWN R. GRZYBOWSKI 24 JUL 2007	Tyco Electronics Harrisburg, PA 17105-3608	
DIMENSIONS: mm		CHK S. FLICKINGER 24 JUL 2007	NAME 2X 28 mm BUS BAR CONNECTOR TORSIONAL BAND CONTACT 6mm THD STUD	
TOLERANCES UNLESS OTHERWISE SPECIFIED: 0 PLC ±.5 1 PLC ±.5 2 PLC ±.25 3 PLC ±. 4 PLC ±. ANGLES ±2 FINISH		APVD S. FLICKINGER 24 JUL 2007	RESTRICTED TO	
MATERIAL		PRODUCT SPEC - APPLICATION SPEC -	SIZE A2	CAGE CODE 00779
-		WEIGHT -	DRAWING NO 1643904	REV B
CUSTOMER DRAWING			SCALE 3:1	SHEET 1 OF 3

THIS DRAWING IS UNPUBLISHED. RELEASED FOR PUBLICATION 20
 © COPYRIGHT 20 BY TYCO ELECTRONICS CORPORATION. ALL RIGHTS RESERVED.

LOC	DIST	REVISIONS			
P	LTR	DESCRIPTION	DATE	DWN	APVD
GP	00	-	SEE SHEET 1	-	-

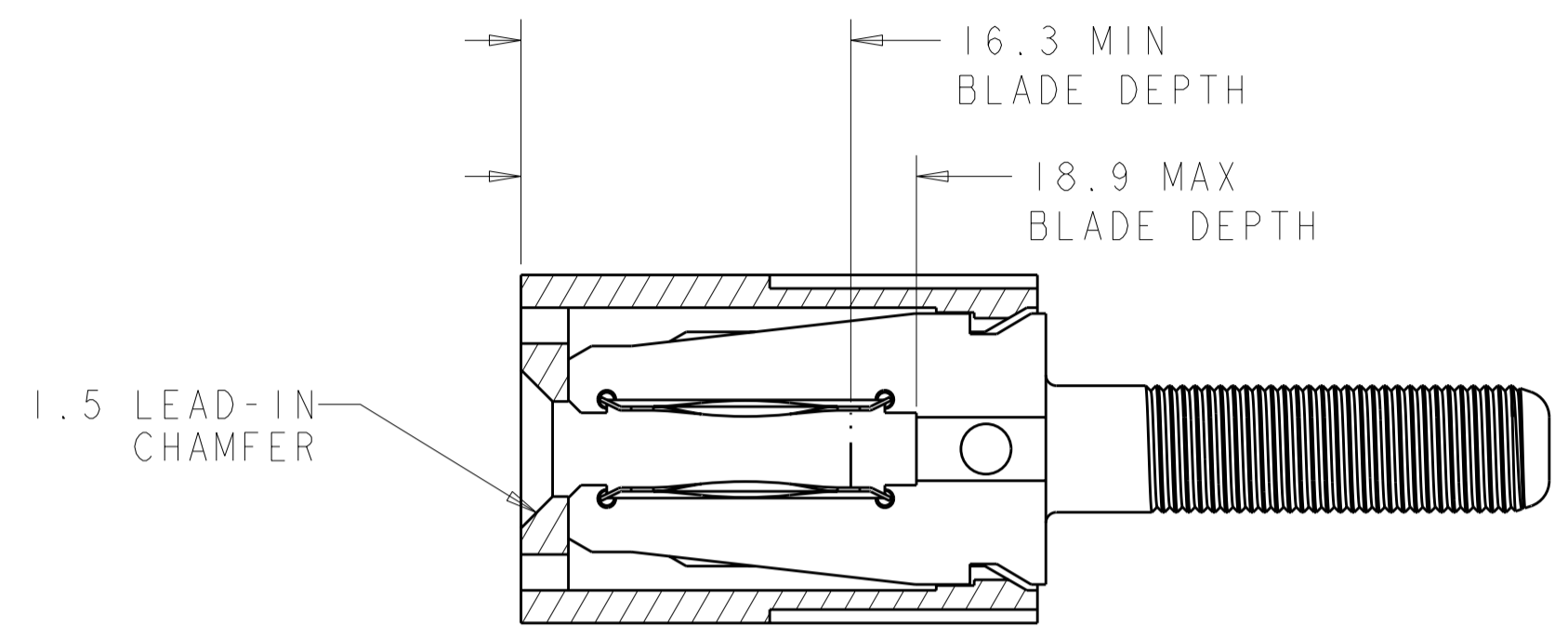
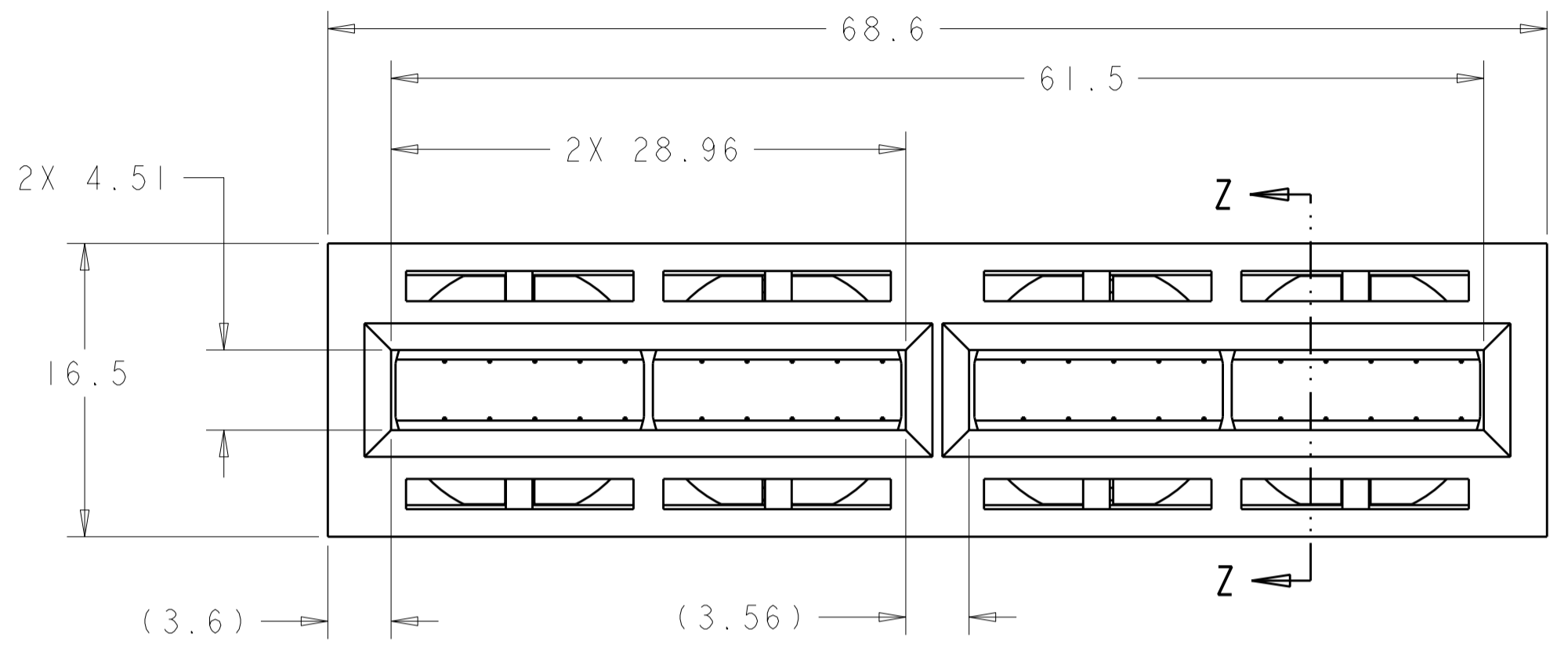

SECTION Z-Z

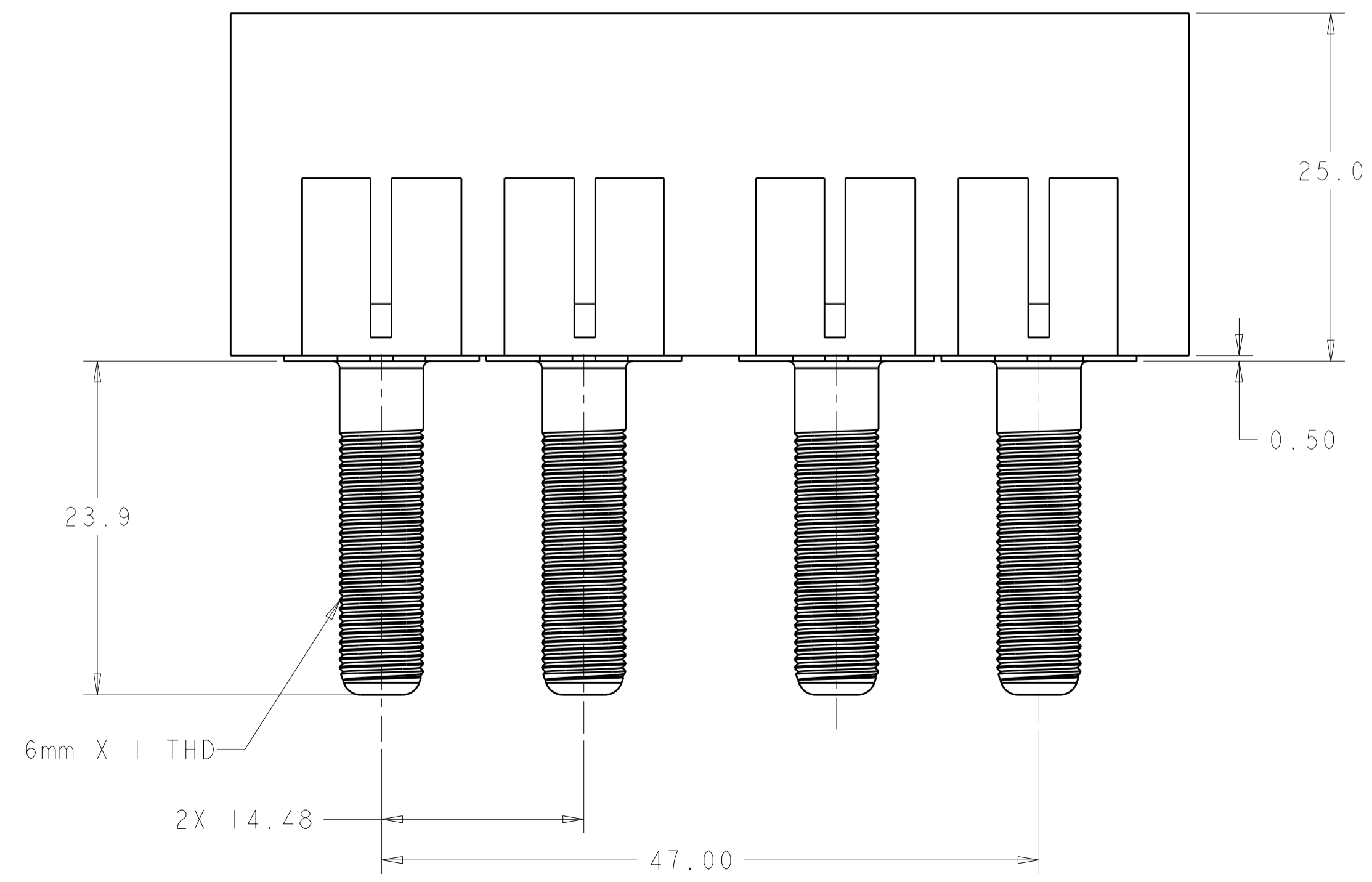

<small>THIS DRAWING IS A CONTROLLED DOCUMENT FOR TYCO ELECTRONICS CORPORATION. IT IS SUBJECT TO CHANGE AND THE CONTROLLING ENGINEERING ORGANIZATION SHOULD BE CONTACTED FOR THE LATEST REVISION.</small>		DWN 24 JUL 2007 R. GRZYBOWSKI CHK 24 JUL 2007 S. FLICKINGER APVD 24 JUL 2007 S. FLICKINGER	Tyco Electronics Harrisburg, PA 17105-3608
DIMENSIONS: mm	TOLERANCES UNLESS OTHERWISE SPECIFIED: 0 PLC ±.5 1 PLC ±.5 2 PLC ±.25 3 PLC ±. 4 PLC ±. ANGLES ±2 FINISH	PRODUCT SPEC APPLICATION SPEC WEIGHT CUSTOMER DRAWING	NAME 2X 28 mm BUS BAR CONNECTOR TORSIONAL BAND CONTACT 6mm THD STUD
MATERIAL		SIZE A200779	CAGE CODE C-1643904
SCALE 3:1		SHEET 2 OF 3	REV B

THIS DRAWING IS UNPUBLISHED. RELEASED FOR PUBLICATION 20
 © COPYRIGHT 20 BY TYCO ELECTRONICS CORPORATION. ALL RIGHTS RESERVED.

LOC	DIST	REVISIONS				
P	LTR	DESCRIPTION	DATE	DWN	APVD	
GP	00	-	SEE SHEET 1	-	-	

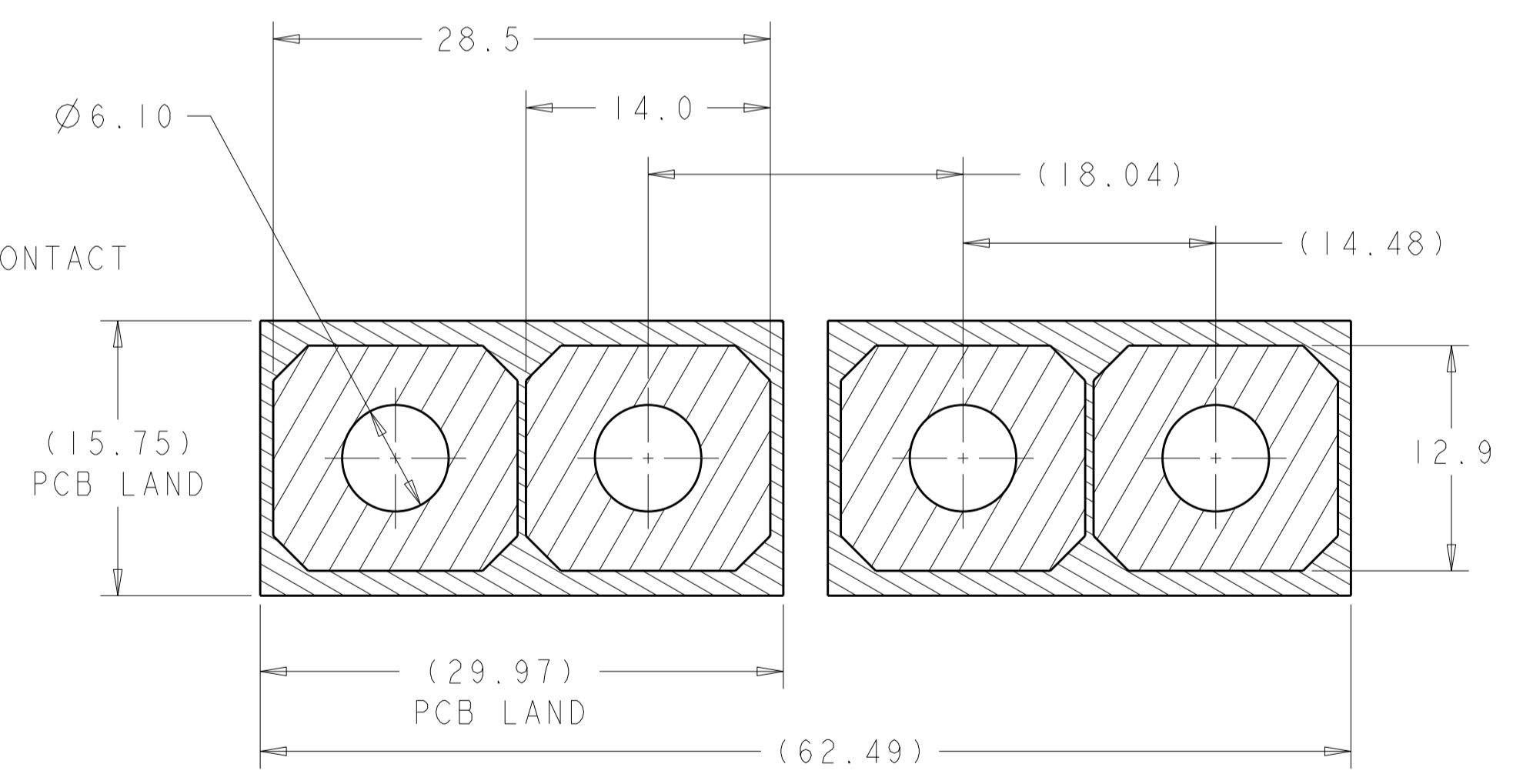
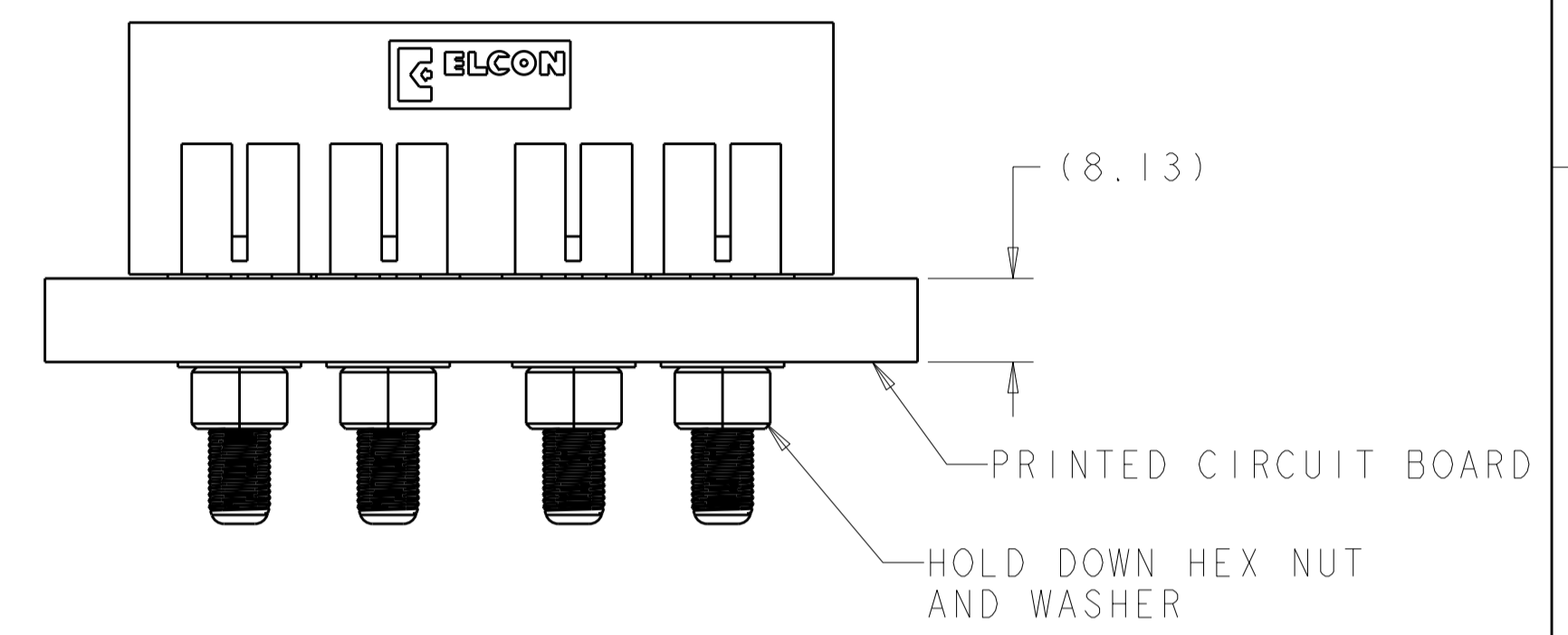
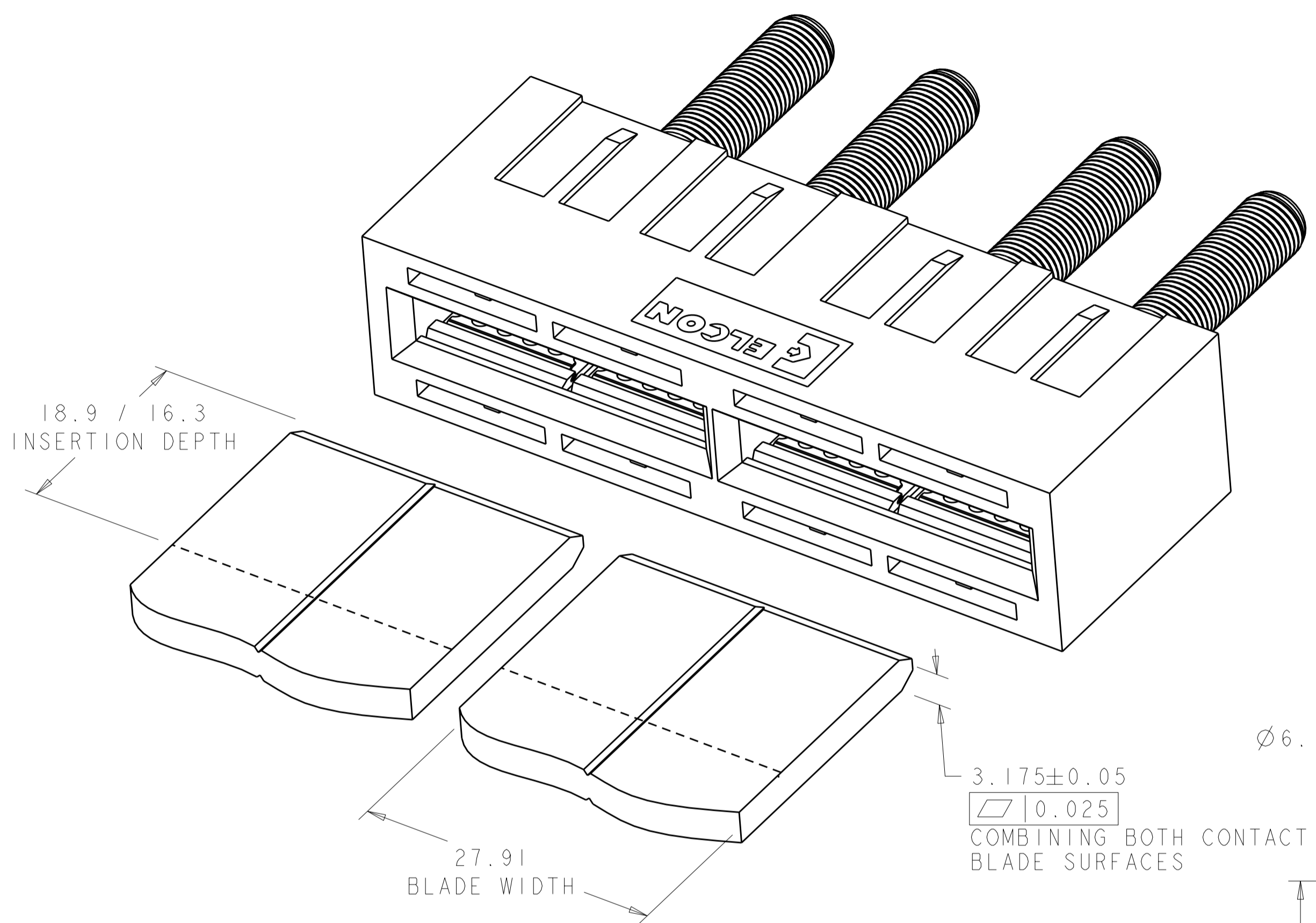

PCB LAND PATTERN OVERLAY

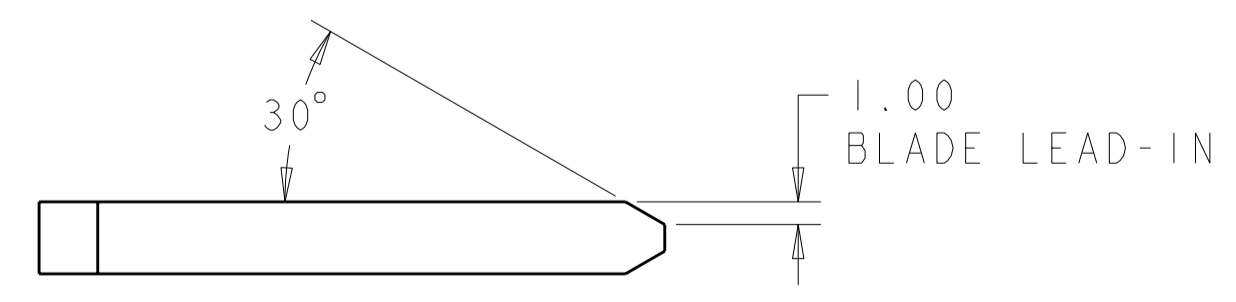

<small>THIS DRAWING IS A CONTROLLED DOCUMENT FOR TYCO ELECTRONICS CORPORATION. IT IS SUBJECT TO CHANGE AND THE CONTROLLING ENGINEERING ORGANIZATION SHOULD BE CONTACTED FOR THE LATEST REVISION.</small>		DWN 24 JUL 2007 R. GRZYBOWSKI CHK 24 JUL 2007 S. FLICKINGER APVD 24 JUL 2007 S. FLICKINGER	Tyco Electronics Harrisburg, PA 17105-3608
DIMENSIONS: mm	TOLERANCES UNLESS OTHERWISE SPECIFIED: 0 PLC ±.5 1 PLC ±.5 2 PLC ±.25 3 PLC ±.25 4 PLC ±. ANGLES ±2 FINISH	PRODUCT SPEC APPLICATION SPEC WEIGHT CUSTOMER DRAWING	NAME 2X 28 mm BUS BAR CONNECTOR TORSIONAL BAND CONTACT 6mm THD STUD SIZE CAGE CODE DRAWING NO RESTRICTED TO A200779C-1643904 -
AMP 1471-9 REV 31MAR2000		SCALE 3:1	SHEET 3 OF 3 REV B

单击下面可查看定价，库存，交付和生命周期等信息

[>>TE Connectivity\(泰科\)](#)