

THIS DRAWING IS UNPUBLISHED. RELEASED FOR PUBLICATION  
 © COPYRIGHT 2010 BY TYCO ELECTRONICS CORPORATION. ALL RIGHTS RESERVED.

LOC	DIST	REVISIONS					
DW	—	P	LTR	DESCRIPTION	DATE	DWN	APVD
		B		OBSELETE	08JAN16	H.X	W.H

NOTE:

- MATERIAL:  
 HOUSING: PA6T WITH 30% GF, UL 94V-0, NATURAL COLOR.  
 ACTUATOR: PPS WITH 45% GF, UL 94V-0, BLACK COLOR.  
 CONTACTS: PHOSPHOR BRONZE.  
 PEGS: PHOSPHOR BRONZE.
- FINISH:  
 CONTACTS: 0.0762µm [3µ"] MIN. GOLD PLATED ON CONTACT AREA, GOLD FLASH ON SOLDER TAIL, WITH ENTIRE CONTACT UNDERPLATED 1.27µm [50µ"] MIN. NICKEL  
 PEGS: 2.54µm [100µ"] MIN. MATTE-TIN OVER 1.27µm [50µ"] MIN. NICKEL
- REFLOW SOLDER CAPABLE TO 260°C AS PER TE SPEC. 109-201, CONDITION B.
- SUBSTANCE RESTRICTIONS FOR LOW HALOGEN (BY WEIGHT):  
 BROMINE (Br) ≤ 900 PPM (0.09%)  
 CHLORINE (Cl) ≤ 900 PPM (0.09%)  
 TOTAL CONCENTRATION OF CHLORINE (Cl) + BROMINE (Br) ≤ 1500 PPM (0.15%)

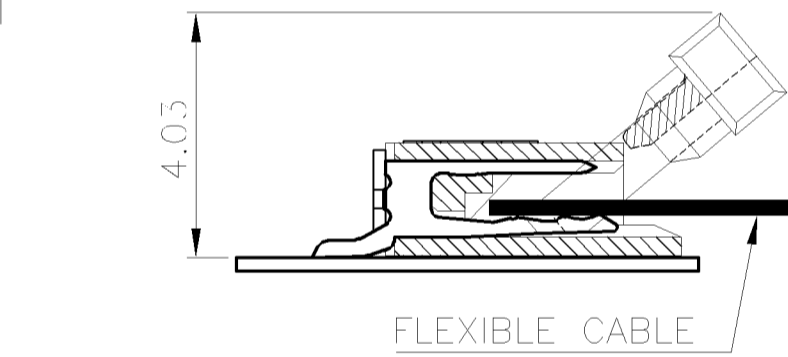
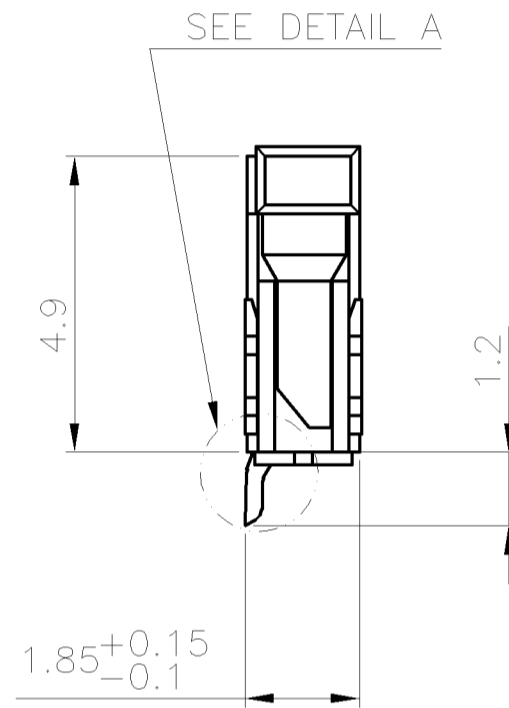
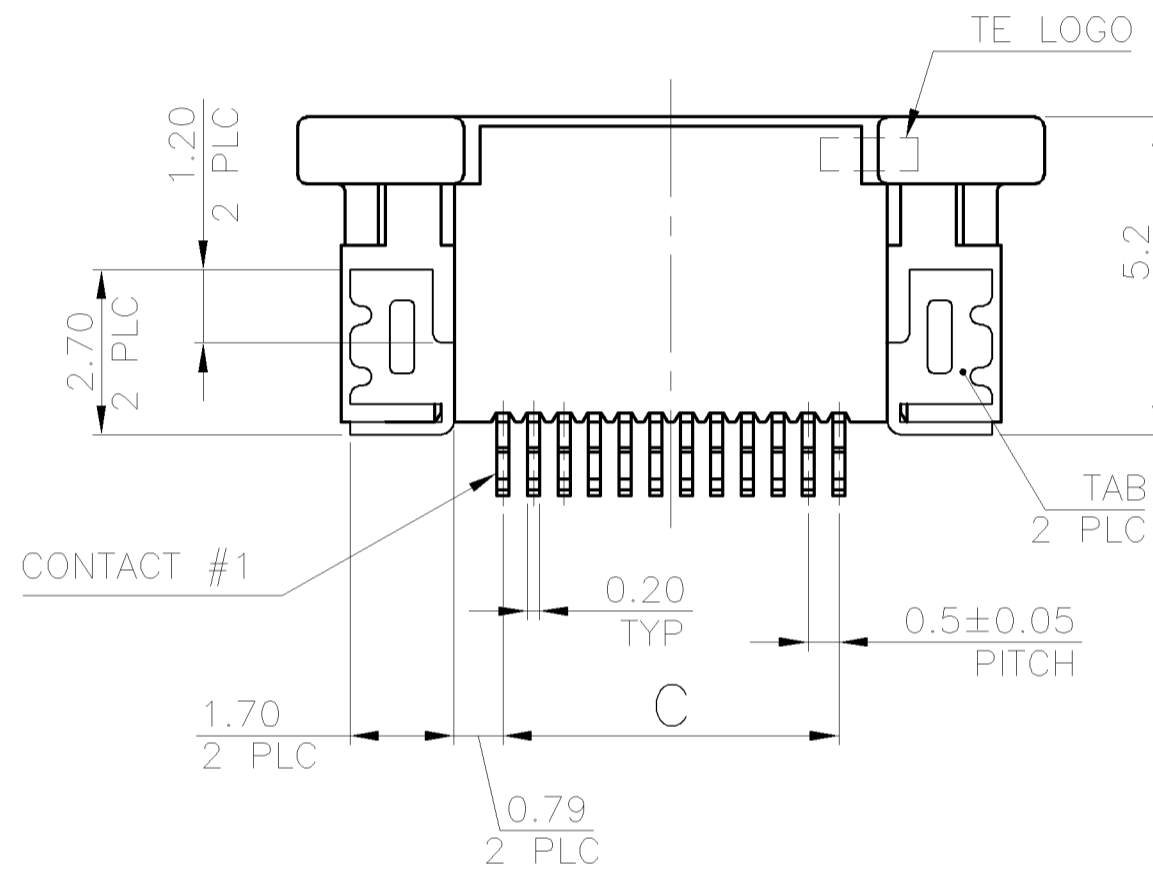
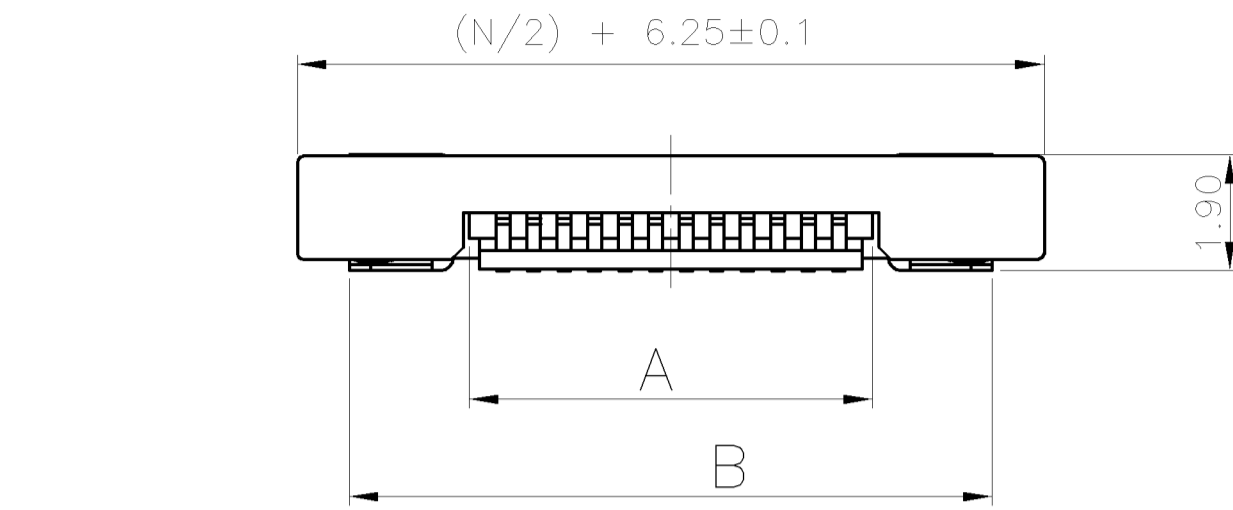

OPEN STATUS

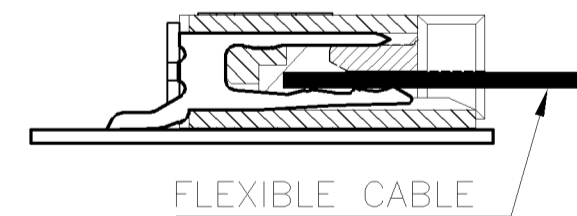

CLOSE STATUS

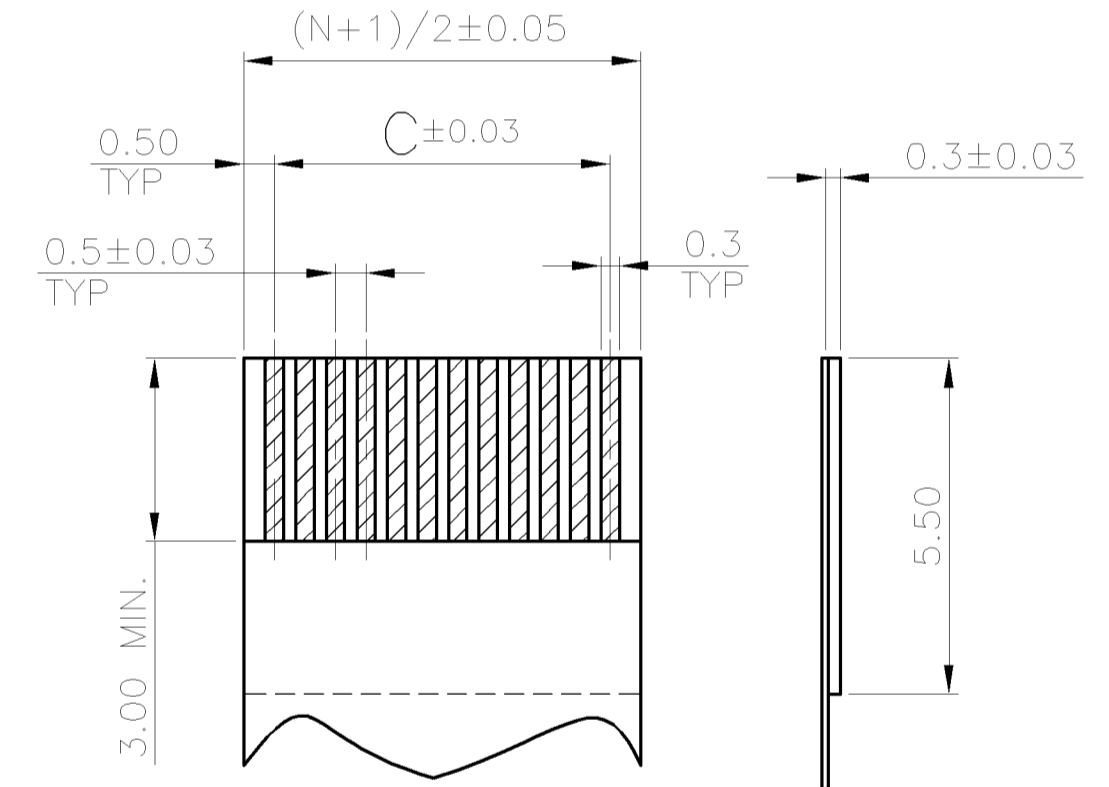

RECOMMENDED FPC/FFC LAYOUT (N = NO. OF CONTACTS)

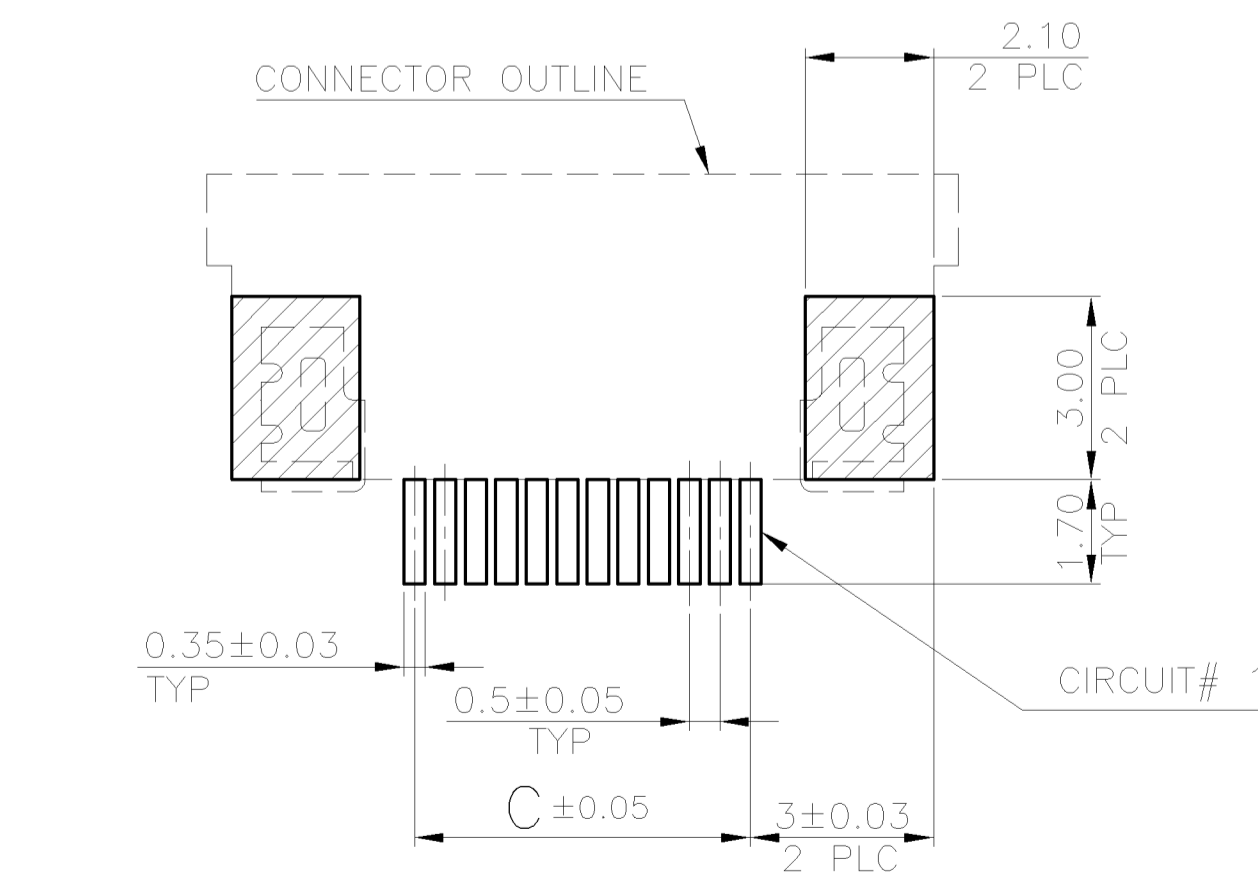

RECOMMENDED PCB LAYOUT

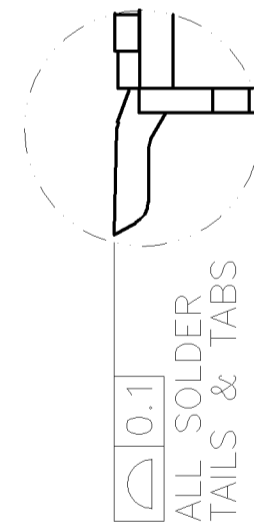

DETAIL A

OBSELETE

<del>6.21</del>	<del>5.5</del>	<del>10.51</del>	<del>6.60</del>	<del>12</del>	<del>1-2041324-2</del>
WEIGHT (GRAMS)	C	B	A	NO. OF CONTACTS	PART NUMBER

THIS DRAWING IS A CONTROLLED DOCUMENT.		DWN	A. WU	03NOV2010	Tyco Electronics Corporation	
DIMENSIONS: MM		CHK	S. CHIEN	03NOV2010	Taipei, Taiwan	
TOLERANCES UNLESS OTHERWISE SPECIFIED:		APVD	W. KODAMA	03NOV2010	NAME	
0 PLC	± -	PRODUCT SPEC		FPC CONNECTOR, 0.5 MM PITCH, ZIF, BOTTOM CONTACT		
1 PLC	± 0.25	108-57364		SIZE	CAGE CODE	DRAWING NO
2 PLC	± 0.2	APPLICATION SPEC		A3	00779	C=2041324
3 PLC	± -	MATERIAL		RESTRICTED TO	-	
4 PLC	± -	FINISH		SCALE	-	
ANGLES	± -	SEE NOTE		SHEET	1 OF 2	
SEE NOTE	SEE NOTE	CUSTOMER DRAWING		REV	B	

THIS DRAWING IS UNPUBLISHED. RELEASED FOR PUBLICATION  
 © COPYRIGHT 2010 BY TYCO ELECTRONICS CORPORATION. ALL RIGHTS RESERVED.

LOC	DIST	REVISIONS					
DW	—	P	LTR	DESCRIPTION	DATE	DWN	APVD
				SEE SHEET 1			

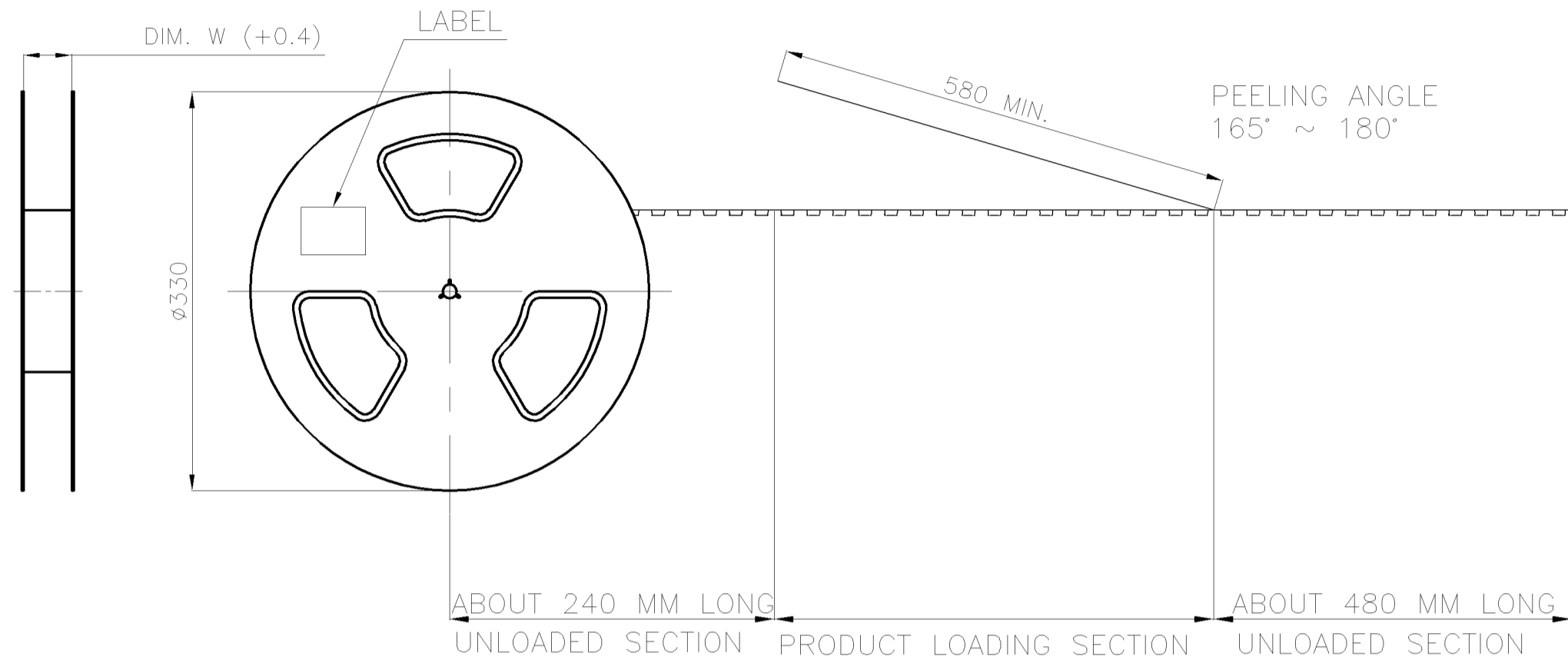

NOTES:

- MATERIAL:  
 BOX: FIBREBOARD, CORRUGATED, DOUBLE WALL.  
 COVER TAPE: PET, TRANSPARENT COLOR.  
 CARRIER TAPE: POLYSTYRENES, TRANSPARENT COLOR.  
 REEL: HIPS, BLUE COLOR.  
 BAG: POLYETHYLENES, TRANSPARENT COLOR.
- EACH BAG SHALL BE INCLUDED DESICCANT.
- PEELING STRENGTH: 0.1 ~ 1.3 N (10 ~ 130 GRAMS).
- PEELING SPEED: 300 mm/min.

USER DIRECTION OF UNREELING

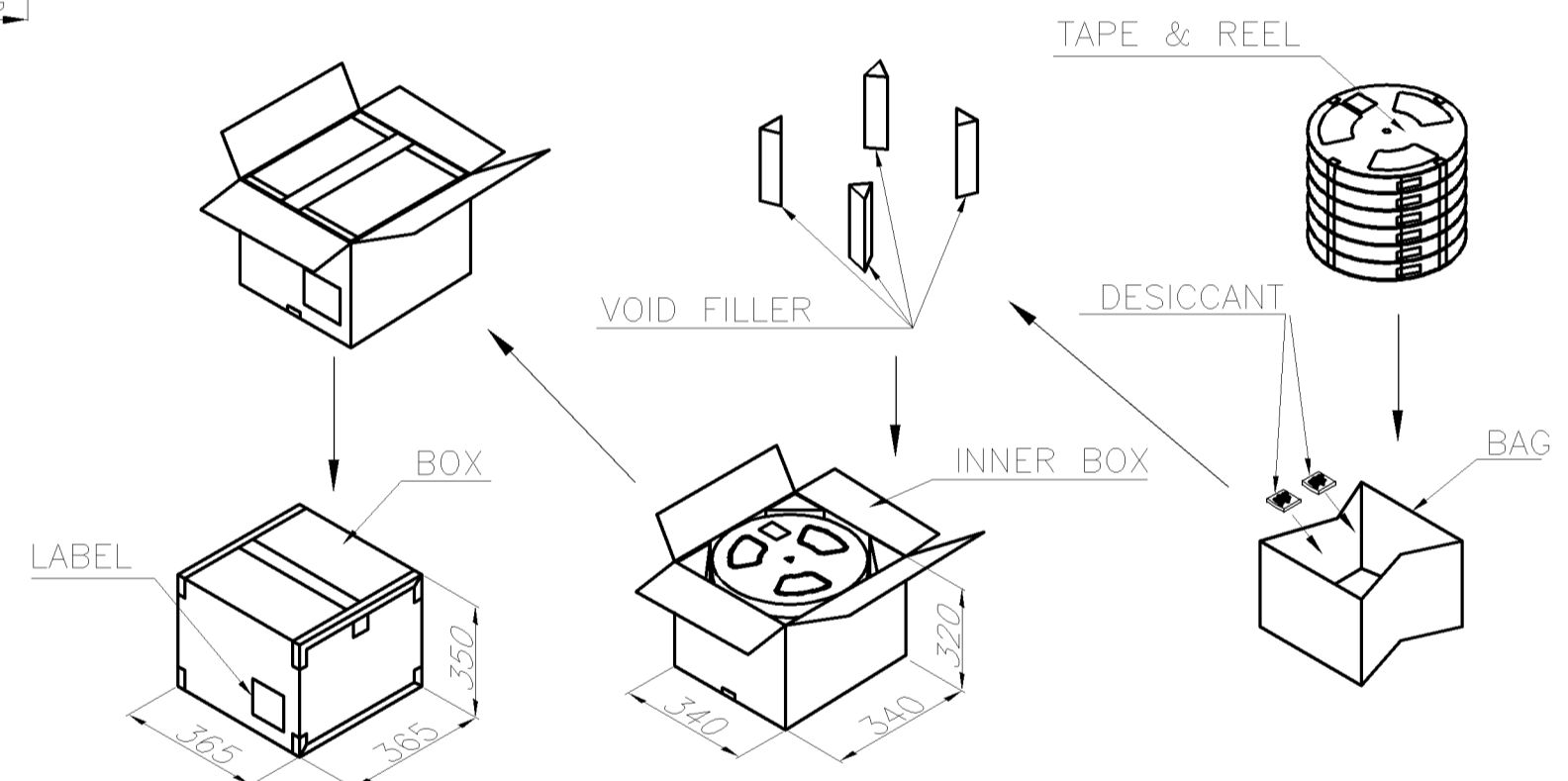
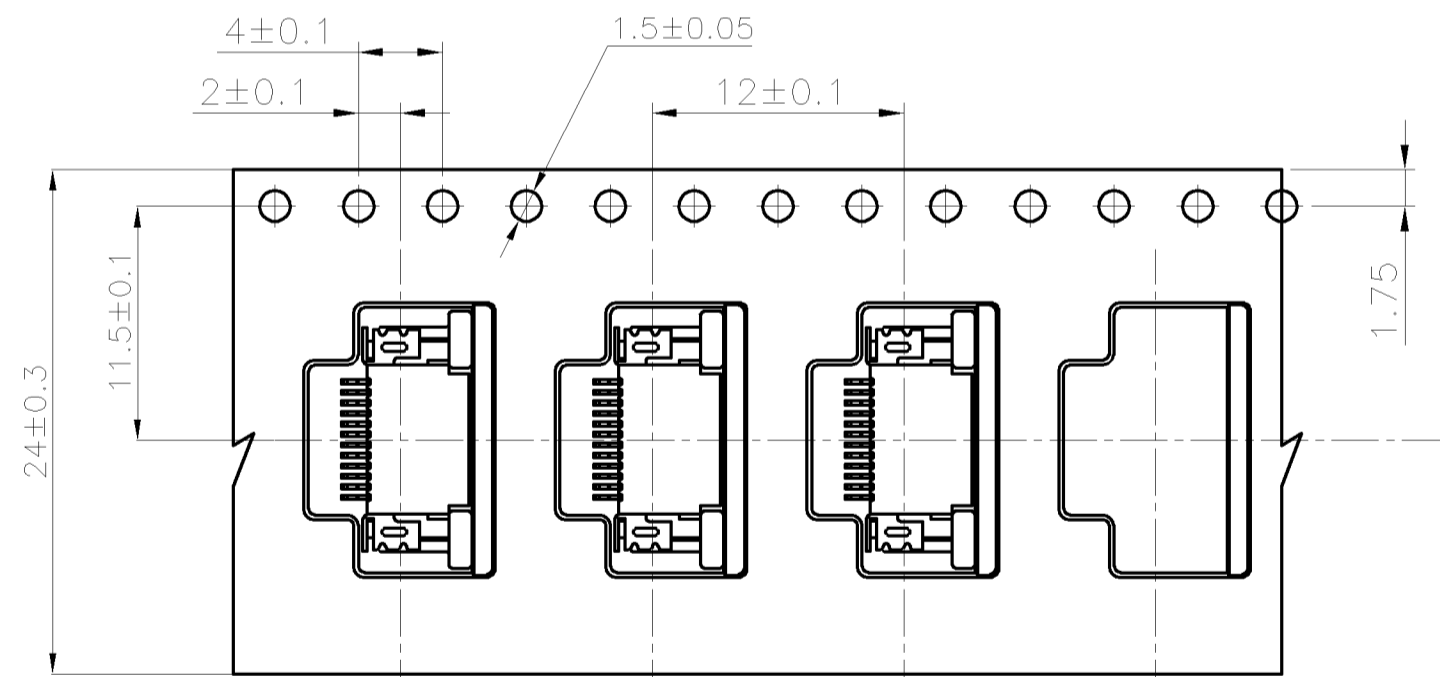

20000	2000	10	8.4	4.2	12
QUANTITY	PCS/TAPE	REELS/BOX	G/W (Kg)	N/W (Kg)	NO. OF CONTACTS

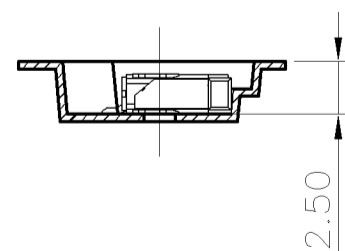

THIS DRAWING IS A CONTROLLED DOCUMENT.		DWN	A. WU	03NOV2010	Tyco Electronics Corporation Taipei, Taiwan		
DIMENSIONS: MM		CHK	S. CHIEN	03NOV2010			
TOLERANCES UNLESS OTHERWISE SPECIFIED:		APVD	W. KODAMA	03NOV2010			
0 PLC ± - 1 PLC ± - 2 PLC ± - 3 PLC ± - 4 PLC ± - ANGLES ± -		PRODUCT SPEC		NAME			
MATERIAL		APPLICATION SPEC		FPC CONNECTOR, 0.5 MM PITCH, ZIF, BOTTOM CONTACT			
FINISH		WEIGHT		SIZE	CAGE CODE	DRAWING NO	RESTRICTED TO
		CUSTOMER DRAWING		A3	00779	G=2041324	—
		SCALE		SHEET		2 OF 2	REV
		—					B

单击下面可查看定价，库存，交付和生命周期等信息

[>>TE Connectivity\(泰科\)](#)