

REVISIONS				
P	LTR	DESCRIPTION	DATE	OWN APVD
A2		REVISED	01FEB18	J.W S.L

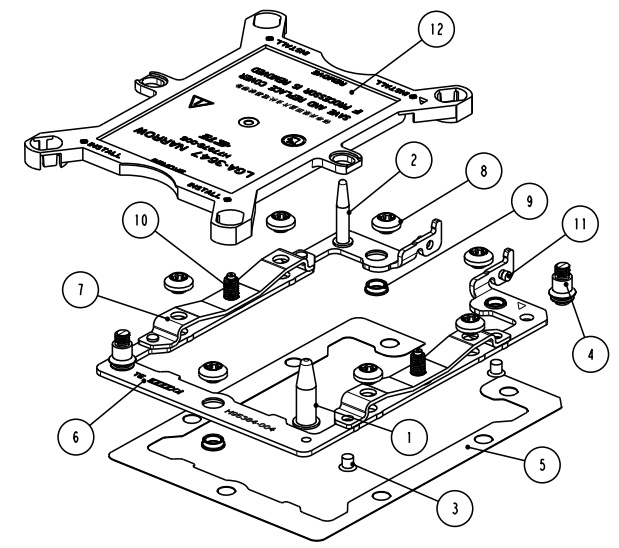
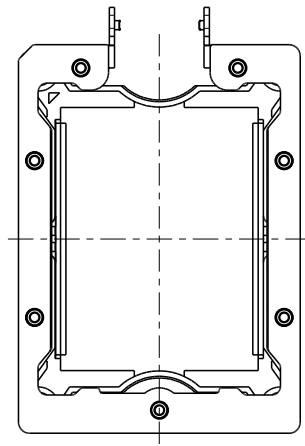
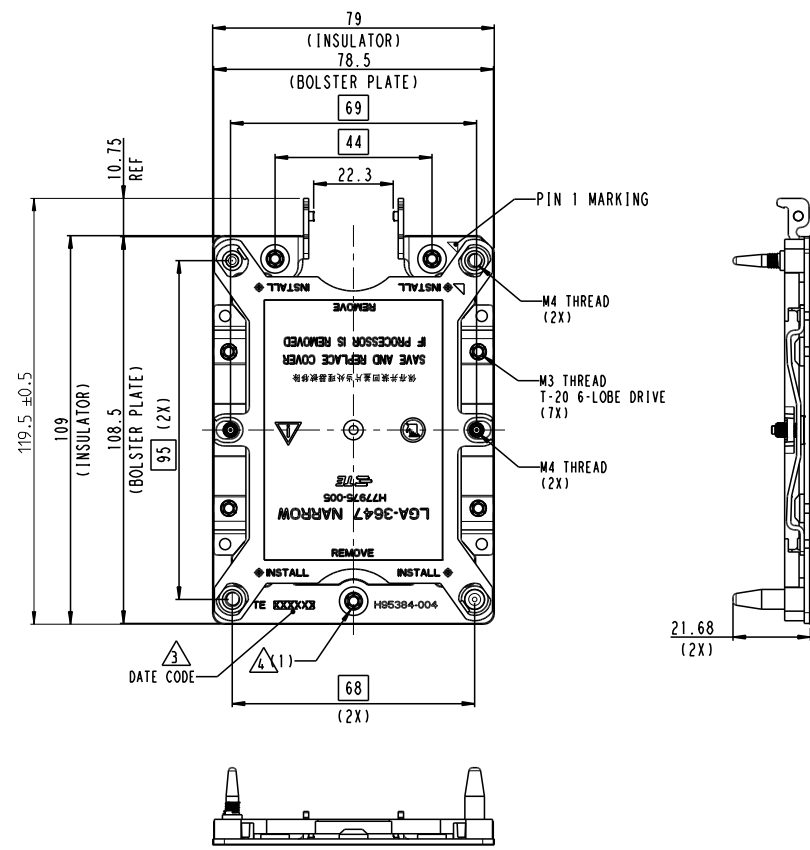

- NOTES:
- MATERIAL:
    - ① BOLSTER LARGE GUIDE POST: STAINLESS STEEL
    - ② BOLSTER SMALL GUIDE POST: STAINLESS STEEL
    - ③ SKT-P-KNL, SPRING RIVET: STAINLESS STEEL
    - ④ SKX BOLSTER CORNER STANDOFF: STAINLESS STEEL
    - ⑤ SKX NRW NON FABRIC BOLSTER INSULATOR: -POLYCARBONATE FILM PLUS ACRYLIC ADHESIVE LAYER
    - ⑥ SKX NRW NON FABRIC BOLSTER PLATE: STAINLESS STEEL
    - ⑦ SKX-EP NRW SPRING: STAINLESS STEEL
    - ⑧ SOCKET P M3 BOLSTER CAPTIVE NUT: CARBON STEEL, NICKEL PLATING
    - ⑨ SOCKET P M3 BOLSTER CAPTIVE NUT COLLAR: CARBON STEEL, NICKEL PLATING
    - ⑩ SKT-EP SPRING STUD: STAINLESS STEEL
    - ⑪ KNL BOLSTER LEC GUIDE PIN: STAINLESS STEEL
    - ⑫ NRW DUST COVER: THERMO-PLASTIC, UL94V-0, BLACK
  - ASSEMBLED WITH BOLSTER ASSEMBLY P/N: 2299805 SERIES
  - INDICATED DATE CODE ON THE BOLSTER PLATE
  - NUT ASSEMBLY SEQUENCE FOR 6 CYCLES: ASSEMBLE (1) AND THE REMAINING NUTS IN ANY ORDER. DISSASSEMBLE IN REVERSE ORDER OF ASSEMBLE

P/N: 2310924-1 AS SHOW (NRW FABRIC TYPE WITH COVER)

Q'TY	DESCRIPTION	ITEM
1	NRW DUST COVER	12
2	KNL BOLSTER LEC GUIDE PIN	11
2	SKT-EP SPRING STUD	10
3	SOCKET P M3 BOLSTER CAPTIVE NUT COLLAR	9
7	SOCKET P M3 BOLSTER CAPTIVE NUT	8
2	SKX-EP NRW SPRING	7
1	SKX NRW FABRIC BOLSTER PLATE	6
1	SKX NRW NON FABRIC BOLSTER INSULATOR	5
2	SKX BOLSTER CORNER STANDOFF	4
4	SKT-P-KNL, SPRING RIVET	3
1	KNL BOLSTER SMALL GUIDE POST	2
1	KNL BOLSTER LARGE GUIDE POST	1

THIS DRAWING IS A CONTROLLED DOCUMENT.

DIMENSIONS: mm	TOLERANCES UNLESS OTHERWISE SPECIFIED: 0 PLC ±0.3 1 PLC ±0.3 2 PLC ±0.3 3 PLC ±0.3 4 PLC ±0.3 ANGLES ±3 FINISH	DWN: 16-Nov-2016 CHE: JEFF WANG APVD: 14-Nov-2016 NAME: SIMON LI PRODUCT SPEC: 108-115115 APPLICATION SPEC: 114-115011 WEIGHT:	DWN: 16-Nov-2016 NAME: COREL WANG PRODUCT SPEC: 108-115115 APPLICATION SPEC: 114-115011 WEIGHT:	SKX-EP NRW FABRIC BOLSTER PLATE ASSY SIZE: A2 CAGE CODE: - DRAWING NO: C=2310924 RESTRICTED TO: - SCALE: 1:1 SHEET: 1 OF 2 REV: A2
----------------	---	--	---	---

CUSTOMER DRAWING

REVISIONS				
P	LTR	DESCRIPTION	DATE	OWN APVD
-	-	SEE SHEET 1	-	-

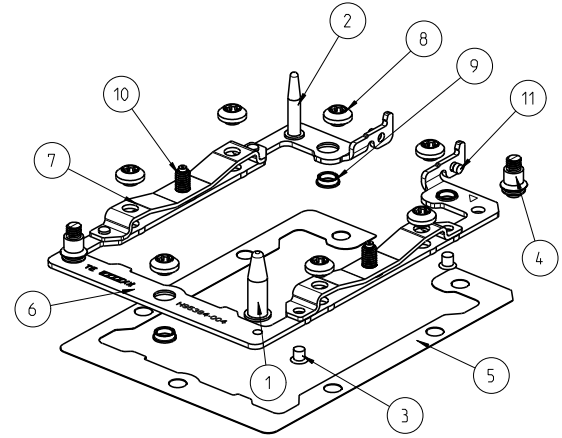
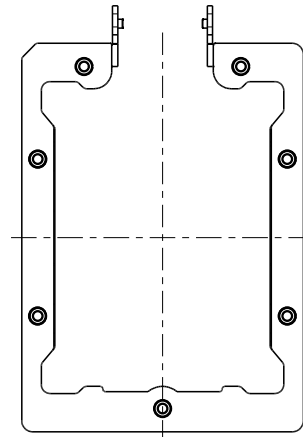
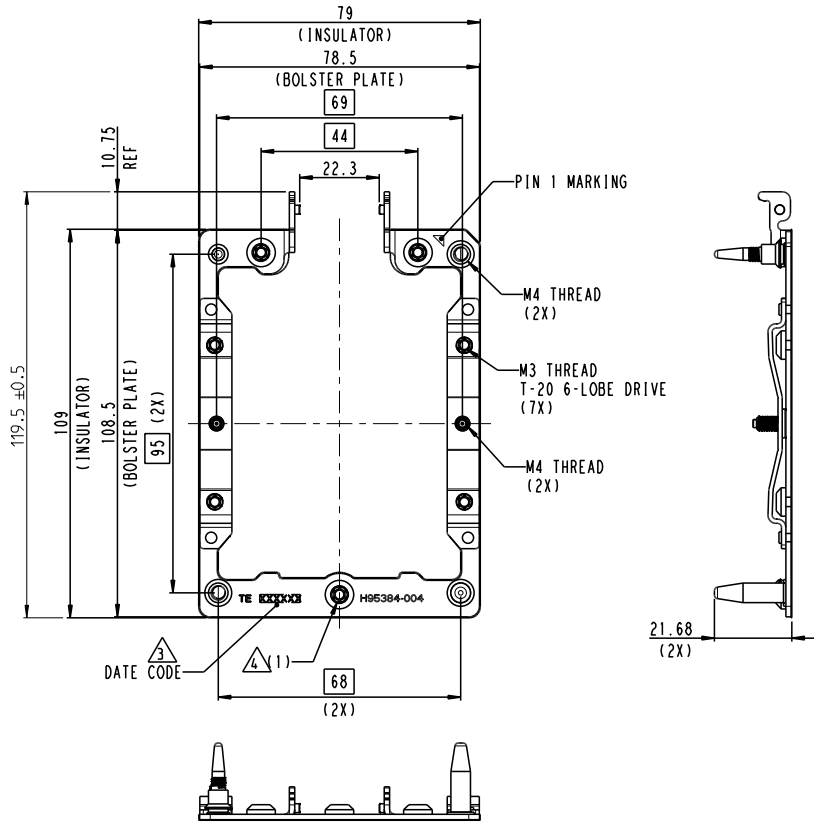

- NOTES:
- MATERIAL:
    - BOLSTER LARGE GUIDE POST: STAINLESS STEEL
    - BOLSTER SMALL GUIDE POST: STAINLESS STEEL
    - SKT-P-KNL, SPRING RIVET: STAINLESS STEEL
    - SKX BOLSTER CORNER STANDOFF: STAINLESS STEEL
    - SKX NRW NON FABRIC BOLSTER INSULATOR: -POLYCARBONATE FILM PLUS ACRYLIC ADHESIVE LAYER
    - SKX NRW NON FABRIC BOLSTER PLATE: STAINLESS STEEL
    - SKX-EP NRW SPRING: STAINLESS STEEL
    - SOCKET P M3 BOLSTER CAPTIVE NUT: CARBON STEEL, NICKEL PLATING
    - SOCKET P M3 BOLSTER CAPTIVE NUT COLLAR: CARBON STEEL, NICKEL PLATING
    - SKT-EP SPRING STUD: STAINLESS STEEL
    - KNL BOLSTER LEC GUIDE PIN: STAINLESS STEEL
  - ASSEMBLED WITH BOLSTER ASSEMBLY P/N: 2299805 SERIES
  - INDICATED DATE CODE ON THE BOLSTER PLATE
  - NUT ASSEMBLY SEQUENCE FOR 6 CYCLES: ASSEMBLE (1) AND THE REMAINING NUTS IN ANY ORDER. DISASSEMBLE IN REVERSE ORDER OF ASSEMBLE

P/N: 2310924-3 AS SHOW (NRW FABRIC TYPE WITHOUT COVER)

Q'TY	DESCRIPTION	ITEM
2	KNL BOLSTER LEC GUIDE PIN	11
2	SKT-EP SPRING STUD	10
3	SOCKET P M3 BOLSTER CAPTIVE NUT COLLAR	9
7	SOCKET P M3 BOLSTER CAPTIVE NUT	8
2	SKX-EP NRW SPRING	7
1	SKX NRW FABRIC BOLSTER PLATE	6
1	SKX NRW NON FABRIC BOLSTER INSULATOR	5
2	SKX BOLSTER CORNER STANDOFF	4
4	SKT-P-KNL, SPRING RIVET	3
1	KNL BOLSTER SMALL GUIDE POST	2
1	KNL BOLSTER LARGE GUIDE POST	1

THIS DRAWING IS A CONTROLLED DOCUMENT.

DIMENSIONS: mm	TOLERANCES UNLESS OTHERWISE SPECIFIED: 0 PLC ±0.3 1 PLC ±0.3 2 PLC ±0.3 3 PLC ±0.3 4 PLC ±0.3 ANGLES ±3 FINISH	DWN: 16-Nov-2016 CHE: JEFF WANG SIMON LI APVD: 16-Nov-2016 LOREL WANG PRODUCT SPEC: 108-115115 APPLICATION SPEC: 114-115011 WEIGHT:	NAME: SKX-EP NRW FABRIC BOLSTER PLATE ASSY SIZE: A2 CAGE CODE: - DRAWING NO: C=2310924 RESTRICTED TO: - SCALE: 1:1 SHEET: 2 OF 2 REV: A2
----------------	---	--	---

CUSTOMER DRAWING

单击下面可查看定价，库存，交付和生命周期等信息

[>>TE Connectivity\(泰科\)](#)