

REVISION(S)			
LTR	DESCRIPTION	INIT	APP'D
O	ECN: 0S60-0055-04	E.T 03/03/04	B.P 03/04/04
A	ECR-06-011163	E.T 5/18/06	V.K 5/18/06

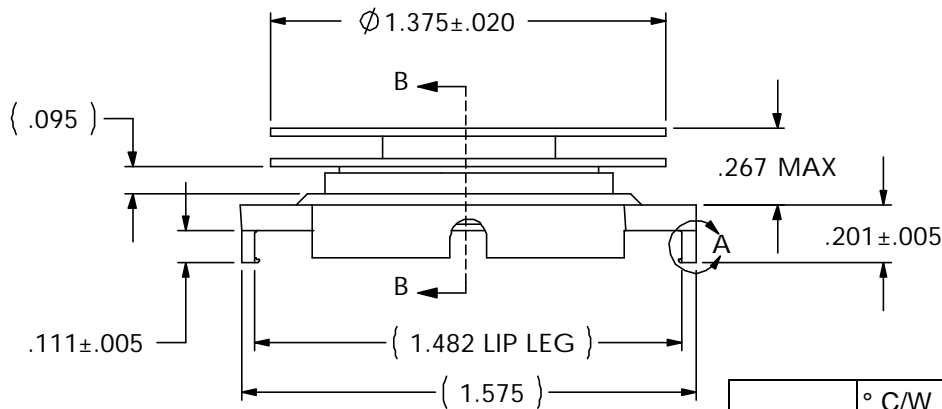

$\phi 1" - 27 \text{ UNS} - 2A$   
THREAD

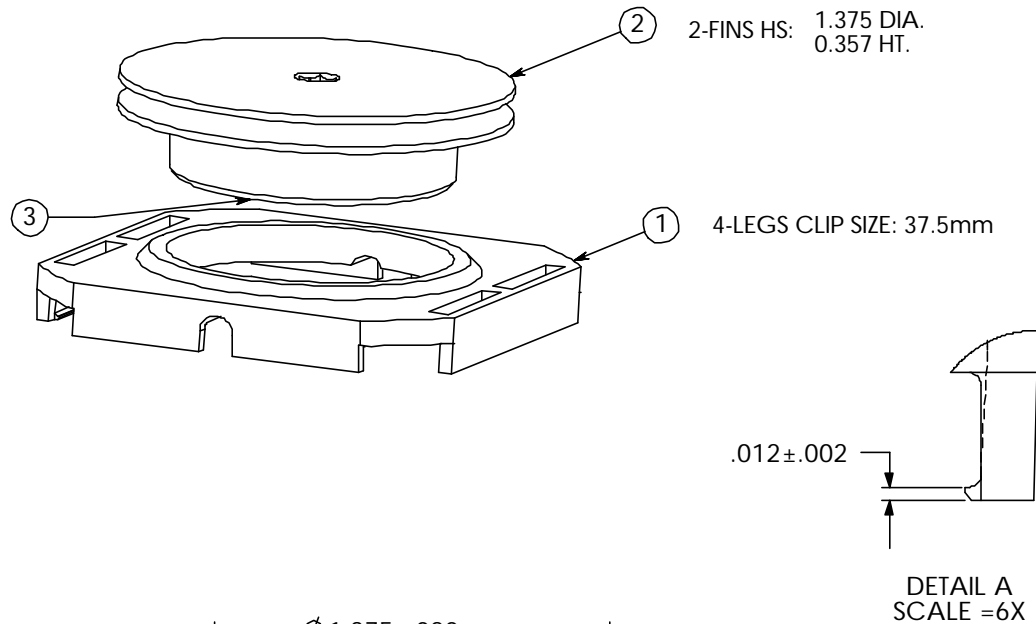
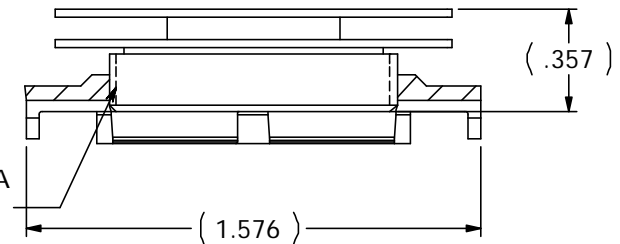

SECTION B-B

Power	° C/W @ Ambient	° C/W @ 200 LFM	° C/W @ 400 LFM	° C/W @ 600 LFM
5 Watts	12.04	6.32	4.30	3.00
10 Watts	10.94	6.44	4.49	3.24
15 Watts	10.07	6.44	4.59	3.26

### CUSTOMER DRAWING

SPECIFICATIONS ARE SUBJECT TO CHANGE WITHOUT NOTICE

ITEM	DESCRIPTION	QTY
1	MOUNTING CLIP	1
2	HEAT SINK	1
3	INTERFACE	1

DO NOT SCALE

**tyco** / Electronics

Attleboro Falls Massachusetts 02763

UNLESS OTHERWISE SPECIFIED TOLERANCES ARE:  
.XX ± .  
.XXX ± .  
.XXXX ± .  
ANGLES ± °

DRAWN BY: E.TAO	DATE 03/03/04	MATERIAL: SEE NOTE
ENGINEER: B.P	DATE 03/04/04	FINISH: SEE NOTE
FILENAME	PROJECT	SYSTEM

CONFIDENTIAL PROPERTY OF TYCO ELECTRONICS. NOT TO BE DISCLOSED TO OTHERS. REPRODUCED OR USED FOR ANY PURPOSES EXCEPT AS AUTHORIZED IN WRITING BY AN AUTHORIZED OFFICIAL OF TYCO. MUST BE RETURNED TO TYCO ON DEMAND, ON COMPLETION OF ORDERS OR OTHER PURPOSES FOR WHICH LENT.

TITLE:  
**37.5mm HS ASS'Y (HTS365-U)**

DIMENSIONS ARE IN: INCHES	SCALE: 1.5:1	PART NO: <b>1-1542002-1</b>	SHEET: 1 OF 1
THIRD ANGLE PROJECTION	SIZE: <b>A</b>	DWG. NO. <b>C-1-1542002-1</b>	REV: <b>A</b>

单击下面可查看定价，库存，交付和生命周期等信息

[>>TE Connectivity\(泰科\)](#)