

THIS DRAWING IS UNPUBLISHED. RELEASED FOR PUBLICATION 20
 © COPYRIGHT 20 BY TYCO ELECTRONICS CORPORATION. ALL RIGHTS RESERVED.

LOC		DIST		REVISIONS			
P	LTR	DESCRIPTION	DATE	DWN	APVD		
DF	A5	5	REVIS	18MAY07	BH JPM		
		6	REVIS	17APR2010	RF JM		

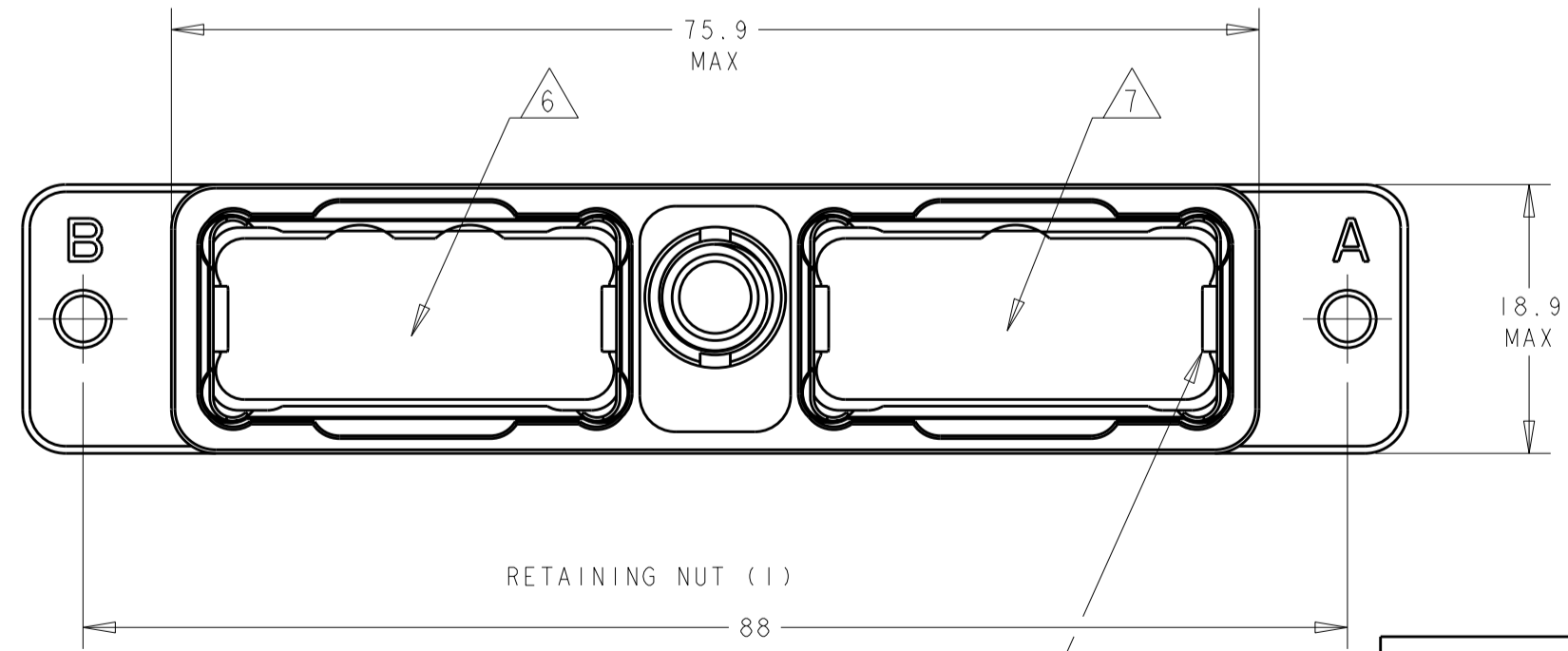
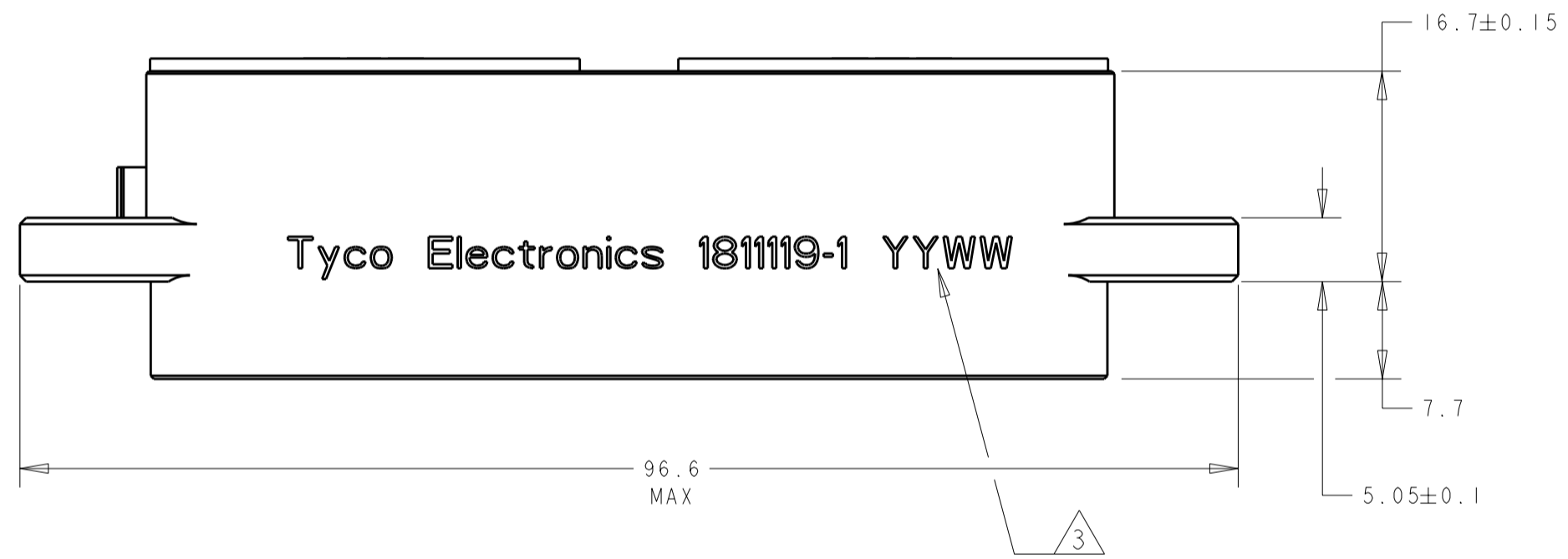
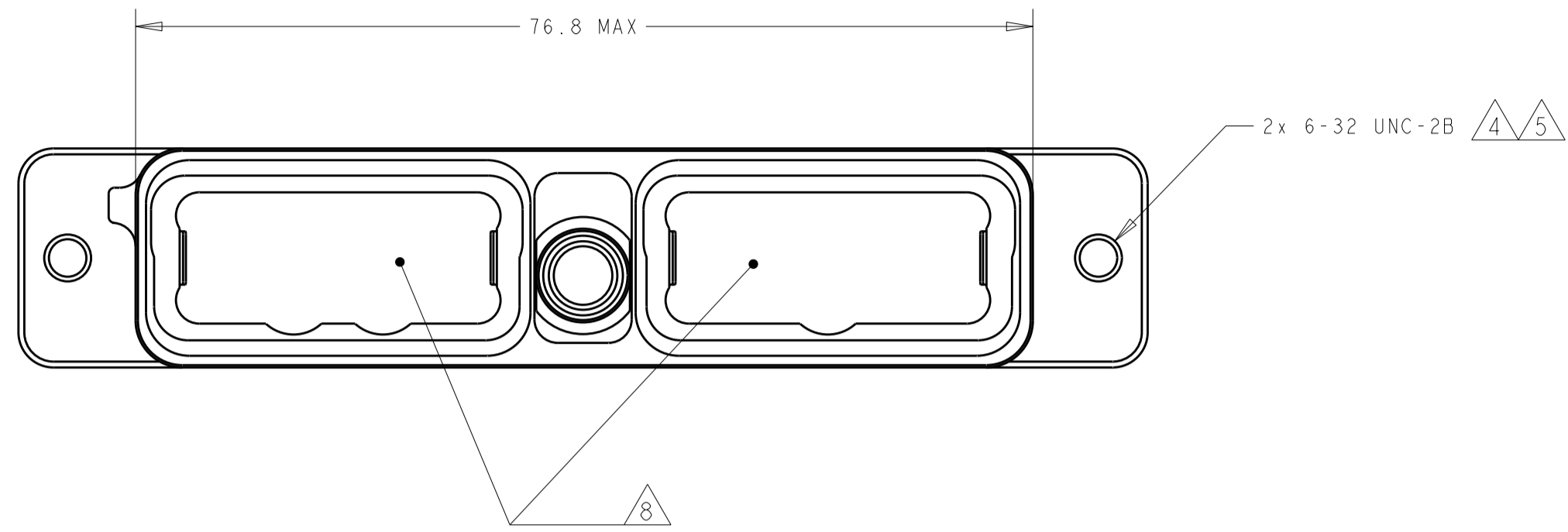

PART NUMBER 1811119-1-1 SHOWN
 SEE SHEET 2 OF 2 FOR PART
 NUMBER 1811119-3 DETAILS.

THIS PRINT IS
PRELIMINARY
 UNQUALIFIED PRODUCT
 CONTACT PRODUCT ENGINEERING
 BEFORE USING THIS PRINT

- 1 SHELL: ALUMINUM ALLOY 6061 T651 PER AMS-QQ-A-250
 INSERT RETENTION CLIP: COPPER ALLOY PER ASTM B194
 GUIDE SOCKET: STAINLESS STEEL PER AISI 303
 RETAINING NUT: STAINLESS STEEL PER AISI 316
 PROTECTIVE COVER: THERMOPLASTIC ELASTOMER
- 2 SHELL: ELECTROLYTIC NICKEL PER SAE AMS QQ-N-290 OVER ELECTROLESS
 NICKEL PER SAE AMS-2404, CLASS 3.
 GUIDE SOCKET: PASSIVATED
- 3 DATE CODE - YEAR & WEEK (YY WW)
- 4 6-32 SCREWS ARE REQUIRED FOR PANEL MOUNTING (NOT INCLUDED).
 SCREW HEAD DIAMETER: 8.5mm MAX
 RECOMMENDED TORQUE: 1.3 N-m [11.5 lb_in] MIN
- 5 6-32 THREADED HOLES ARE SELF-LOCKING, HAVING THE SPIRALOCK® THREAD FORM.
 SPIRALOCK® IS A REGISTERED TRADEMARK OF SPIRALOCK CORPORATION.
- 6 SHELL CAVITY FOR GPRB SERIES INSERT WITH KEYING CODE A.
- 7 SHELL CAVITY FOR GPRB SERIES INSERT WITH KEYING CODE B.
- 8 THE PROTECTIVE COVERS ARE NOT SHOWN FOR CLARITY.
- 9 POLARIZATION FEATURE TO PREVENT REAR PANEL MOUNTING.
- 10. THIS PRODUCT IS SOLD BY TYCO ELECTRONICS UNDER A LICENSE FROM RADIALL SA.

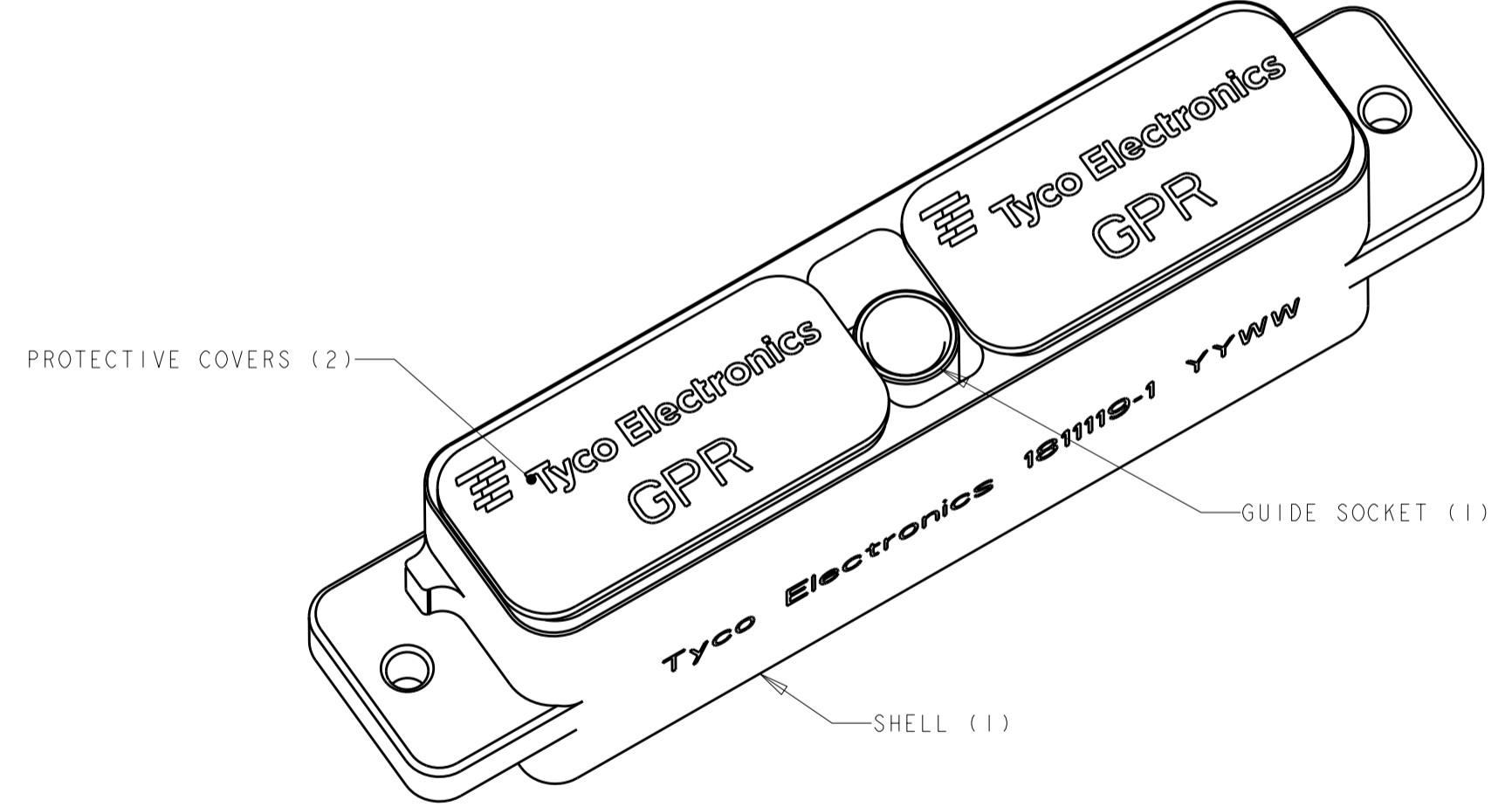

SHELL WITH 2X Ø3.80 MIN THRU MOUNTING HOLES-SEE SHEET 2 DETAILS.	1811119-3
SHELL WITH 2X6-32 UNC-2B MOUNTING HOLES- SEE SHEE 1 DETAILS.	1811119-1
REMARKS	PART NUMBER

THIS DRAWING IS A CONTROLLED DOCUMENT FOR TYCO ELECTRONICS CORPORATION IT IS SUBJECT TO CHANGE AND THE CONTROLLING ENGINEERING ORGANIZATION SHOULD BE CONTACTED FOR THE LATEST REVISION.		DWN BW 15MAR2005	Tyco Electronics Harrisburg, PA 17105-3608
DIMENSIONS: mm		CHK JPM 15MAR2005	
TOLERANCES UNLESS OTHERWISE SPECIFIED: 0 PLC ±0.2 1 PLC ±0.2 2 PLC ±0.2 3 PLC ± 4 PLC ± ANGLES ± FINISH		APVD JPM 15MAR2005	NAME RECEPTACLE SHELL ASSEMBLY, FRONT PANEL-MOUNT, WITH GUIDE SOCKET, GPRB2
MATERIAL		PRODUCT SPEC -	SIZE A200779
1 - 2 -		APPLICATION SPEC -	DRAWING NO C-1811119
		WEIGHT -	RESTRICTED TO -
		CUSTOMER DRAWING	SCALE 2:1 SHEET 1 OF 2 REV 6

THIS DRAWING IS UNPUBLISHED. RELEASED FOR PUBLICATION 20
 © COPYRIGHT 20 BY TYCO ELECTRONICS CORPORATION. ALL RIGHTS RESERVED.

LOC	DIST	REVISIONS			
P	LTR	DESCRIPTION	DATE	DWN	APVD
		SEE SHEET 1			

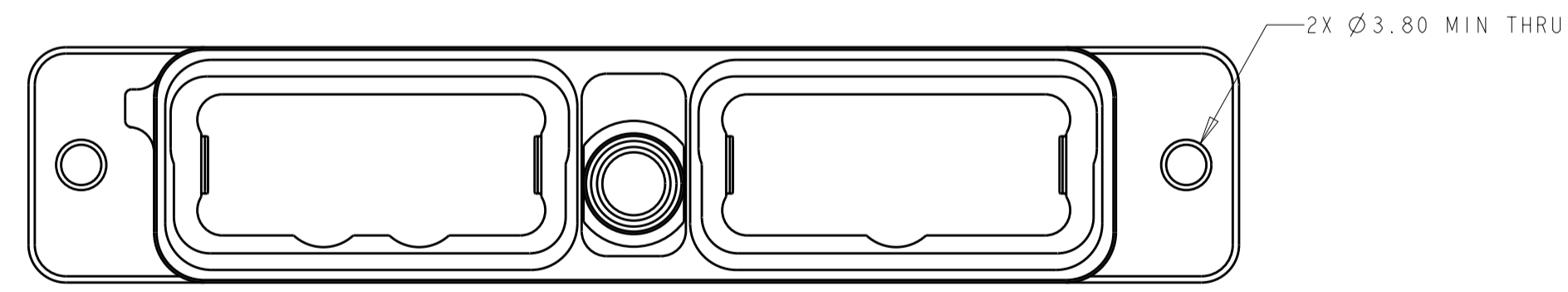
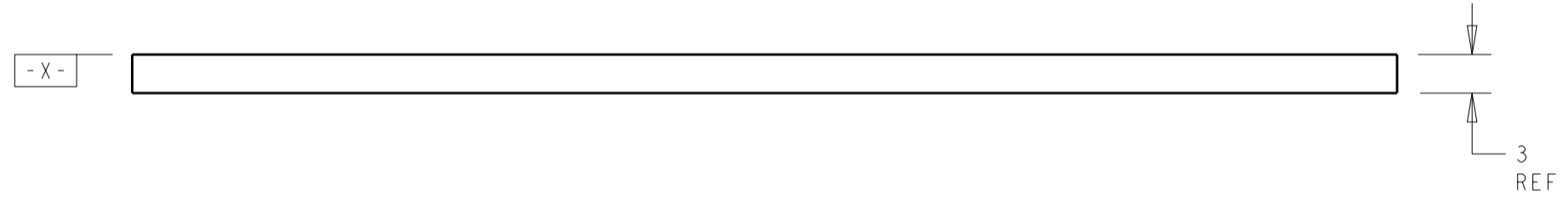
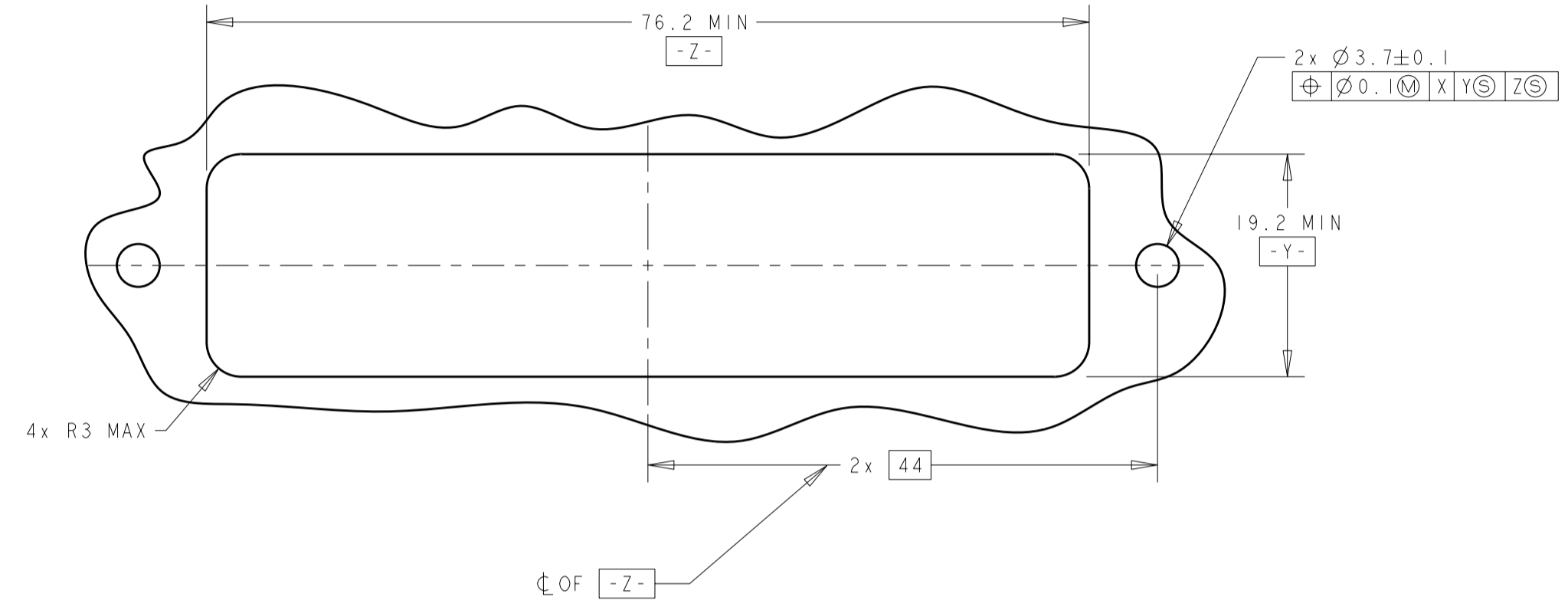

PART NUMBER 1811119-3 SHOWN,
 ALL DIMENSIONS SAME AS
 1811119-1 EXCEPT AS NOTED.

THIS PRINT IS
PRELIMINARY
 UNQUALIFIED PRODUCT
 CONTACT PRODUCT ENGINEERING
 BEFORE USING THIS PRINT

<small>THIS DRAWING IS A CONTROLLED DOCUMENT FOR TYCO ELECTRONICS CORPORATION IT IS SUBJECT TO CHANGE AND THE CONTROLLING ENGINEERING ORGANIZATION SHOULD BE CONTACTED FOR THE LATEST REVISION.</small>		DWN BW	15MAR2005	Tyco Electronics Harrisburg, PA 17105-3608
DIMENSIONS: mm		CHK JPM	15MAR2005	
		APVD JPM	15MAR2005	
TOLERANCES UNLESS OTHERWISE SPECIFIED: 0 PLC ±0.2 1 PLC ±0.2 2 PLC ±0.2 3 PLC ± 4 PLC ± ANGLES ± FINISH		PRODUCT SPEC -	NAME RECEPTACLE SHELL ASSEMBLY, FRONT PANEL-MOUNT, WITH GUIDE SOCKET, GPRB2	RESTRICTED TO -
MATERIAL -		APPLICATION SPEC -	WEIGHT -	SIZE A2
-		CUSTOMER DRAWING	SCALE 1:1	CAGE CODE A200779
-				DRAWING NO 1811119
-				SHEET 2 OF 2
-				REV 6

单击下面可查看定价，库存，交付和生命周期等信息

[>>TE Connectivity\(泰科\)](#)