

THIS DRAWING IS UNPUBLISHED. RELEASED FOR PUBLICATION  
 © COPYRIGHT BY TYCO ELECTRONICS CORPORATION. ALL RIGHTS RESERVED.

LOC	DIST	REVISIONS					
GP	00	P	LTR	DESCRIPTION	DATE	DWN	APVD
		J		REVISED PER ECO-06-028338	11/DEC/06	ZMR	EDB
		J1		REVISED PER ECO-09-021826	07JAN10	KK	AEG

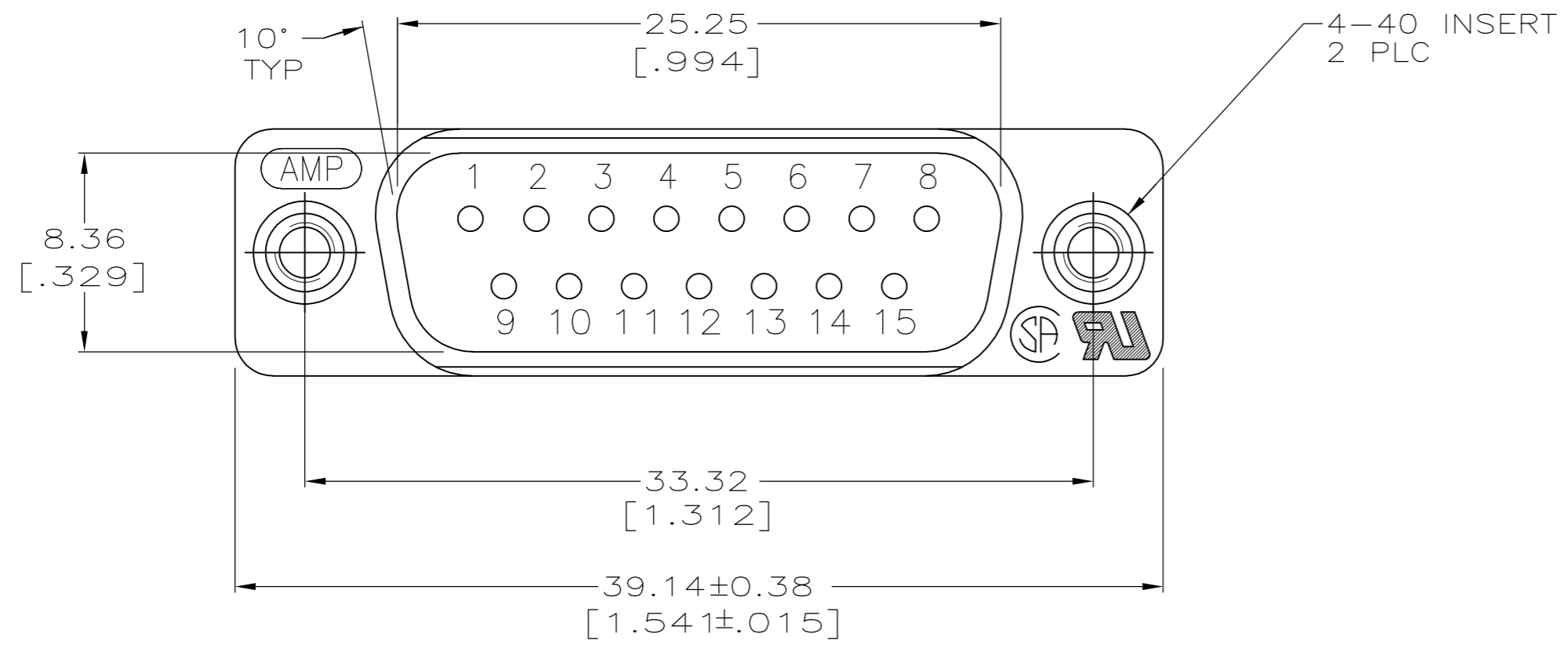

- ① HOUSING: BLACK POLYESTER, UL 94V-0 RATED;  
CONTACTS: BRASS  
INSERTS: BRASS
- ② GOLD PLATED FOR LENGTH OF 3.81 [.150] MIN FROM MATING END, GOLD FLASH IN MATED AREA, 2.54µm [.000100] MIN TIN OR TIN-LEAD FOR A LENGTH OF DIMENSION A FROM OPPOSITE END, BOTH OVER 1.27µm [.000050] MIN NICKEL.
- ③ GOLD PLATED FOR LENGTH OF 3.81 [.150] MIN FROM MATING END, 0.76µm [.000030] MIN GOLD IN MATED AREA, 2.54µm [.000100] MIN TIN OR TIN-LEAD FOR A LENGTH OF DIMENSION A FROM OPPOSITE END, BOTH OVER 1.27µm [.000050] MIN NICKEL.  
-OR-  
GOLD FLASH OVER PALLADIUM NICKEL FOR A LENGTH OF 3.81 [.150] MIN FROM MATING END, 0.76µm [.000030] MIN PALLADIUM NICKEL IN MATED AREA, 2.54µm [.000100] MIN TIN OR TIN-LEAD FOR A LENGTH OF DIMENSION A FROM OPPOSITE END, BOTH OVER 1.27µm [.000050] MIN NICKEL.
- ④ OBSOLETE PARTS: OBSOLETE CIS STREAMLINING PER D.RENAUD/D.SINISI

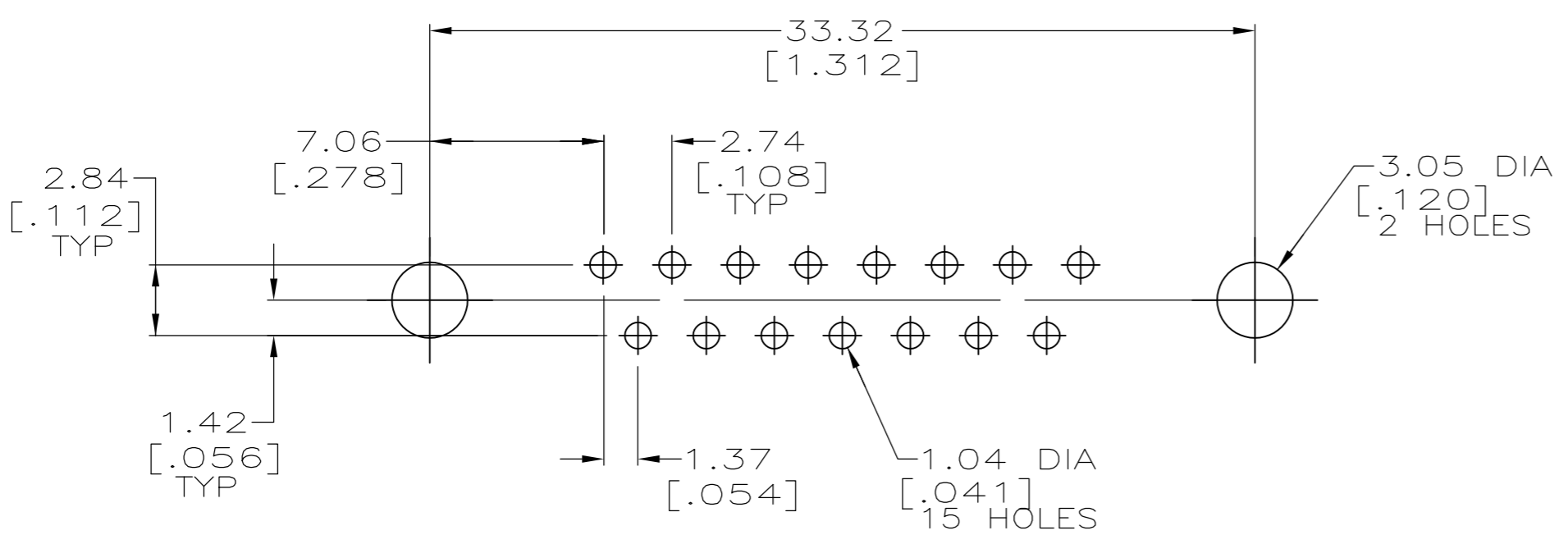
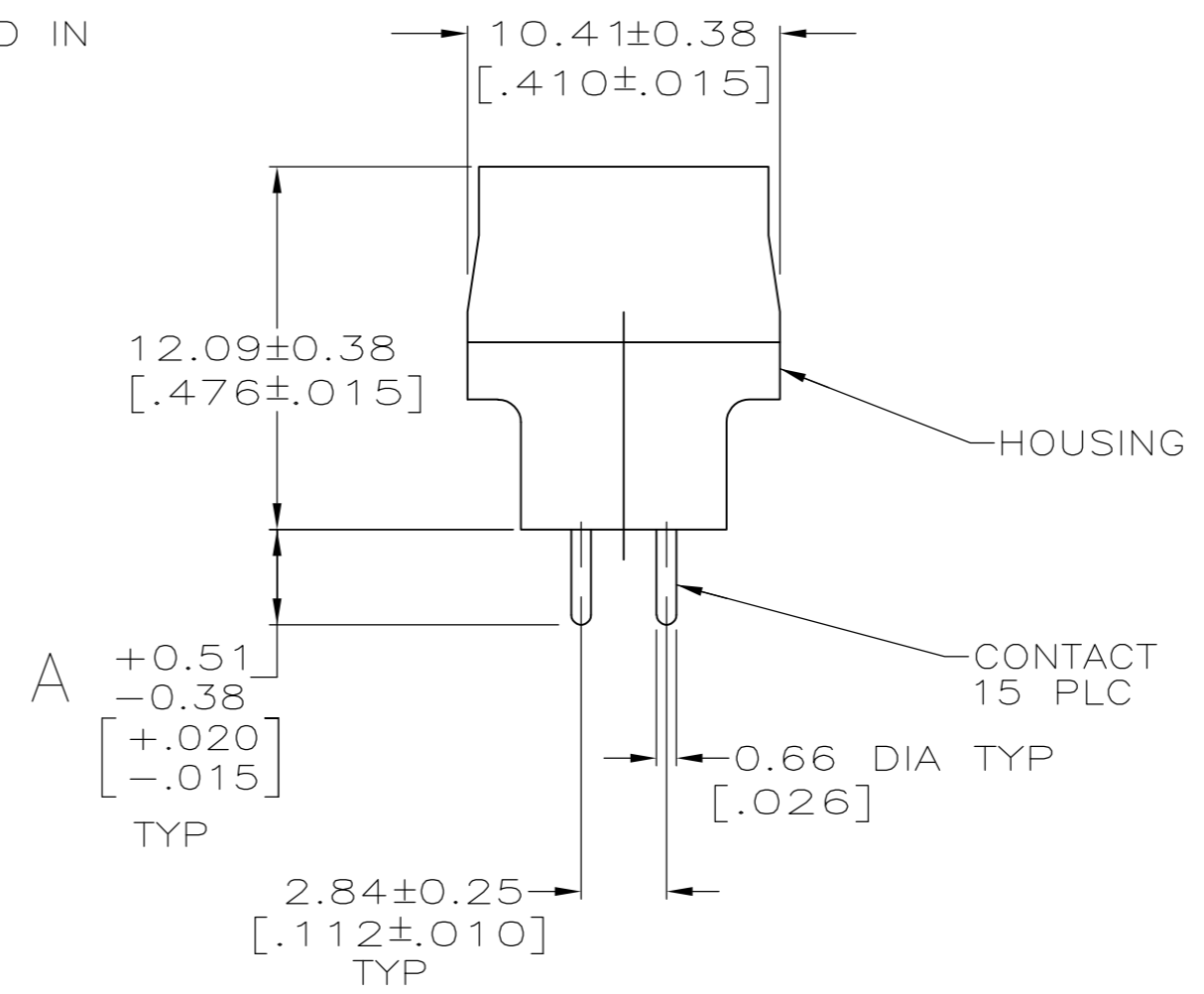
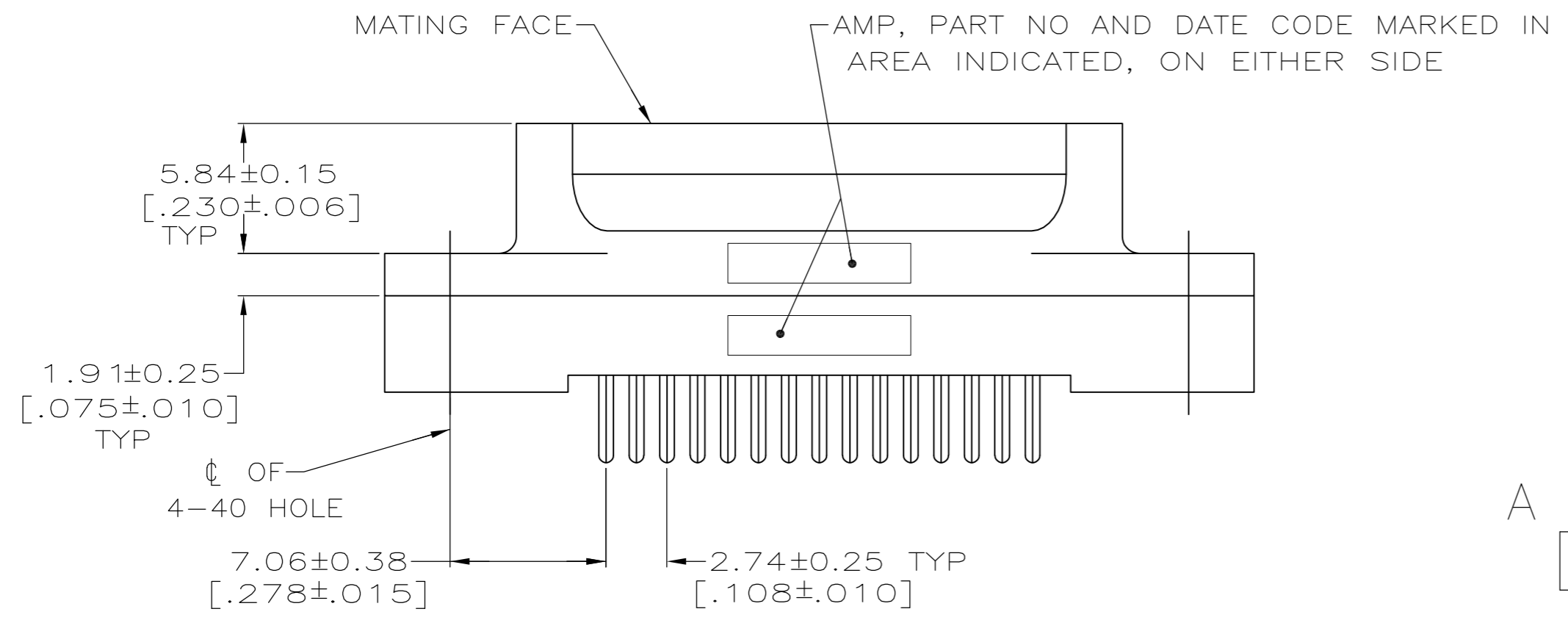

RECOMMENDED PC BOARD MOUNTING DIMENSIONS

	DIMENSION A	CONTACT FINISH	PART NUMBER
③	6.35 [.250]	③	745052-6
②	6.35 [.250]	②	745052-5
③	4.32 [.170]	③	745052-4
②	4.32 [.170]	②	745052-3
③	3.18 [.125]	③	745052-2
④	3.18 [.125]	②	745052-1

THIS DRAWING IS A CONTROLLED DOCUMENT.		DWN J McCLINTON 11-15-89	<b>tyco</b> Tyco Electronics Corporation	
DIMENSIONS: mm [INCHES]		CHK R.STONE 2-1-90	Harrisburg, PA 17105-3608	
TOLERANCES UNLESS OTHERWISE SPECIFIED:		APVD C. ROHDE 2-2-90	NAME	
0 PLC ± -	1 PLC ± -	PRODUCT SPEC	PLUG ASSEMBLY, SIZE 2,	
2 PLC ± 0.13 [.005]	3 PLC ± -	APPLICATION SPEC	15 POSN, VERTICAL,	
4 PLC ± -	ANGLES ± 2°		AMPLIMITE® HD-20	
MATERIAL	FINISH	WEIGHT	SIZE	CAGE CODE
①	CONTACTS: SEE TABLE	-	A2	00779
CUSTOMER DRAWING		SCALE	DRAWING NO	RESTRICTED TO
		NTS	C=745052	-
		SHEET	1 OF 1	REV
				J1

单击下面可查看定价，库存，交付和生命周期等信息

[>>TE Connectivity\(泰科\)](#)