

LOC		DIST		REVISIONS			
GP	00	P	LTN	DESCRIPTION	DATE	OWN	APVD
		A4		REVISED PER ECR-19-006709	10APR2019	IT	SH
		A5		REVISED PER ECO-20-000404	09JAN2020	IT	SH
		A6		REVISED PER ECR-20-015251	28OCT2020	IT	SH
		A7		ADD NEW DASH NUMBER 1-2149730-4	02NOV2021	SZ	SZ

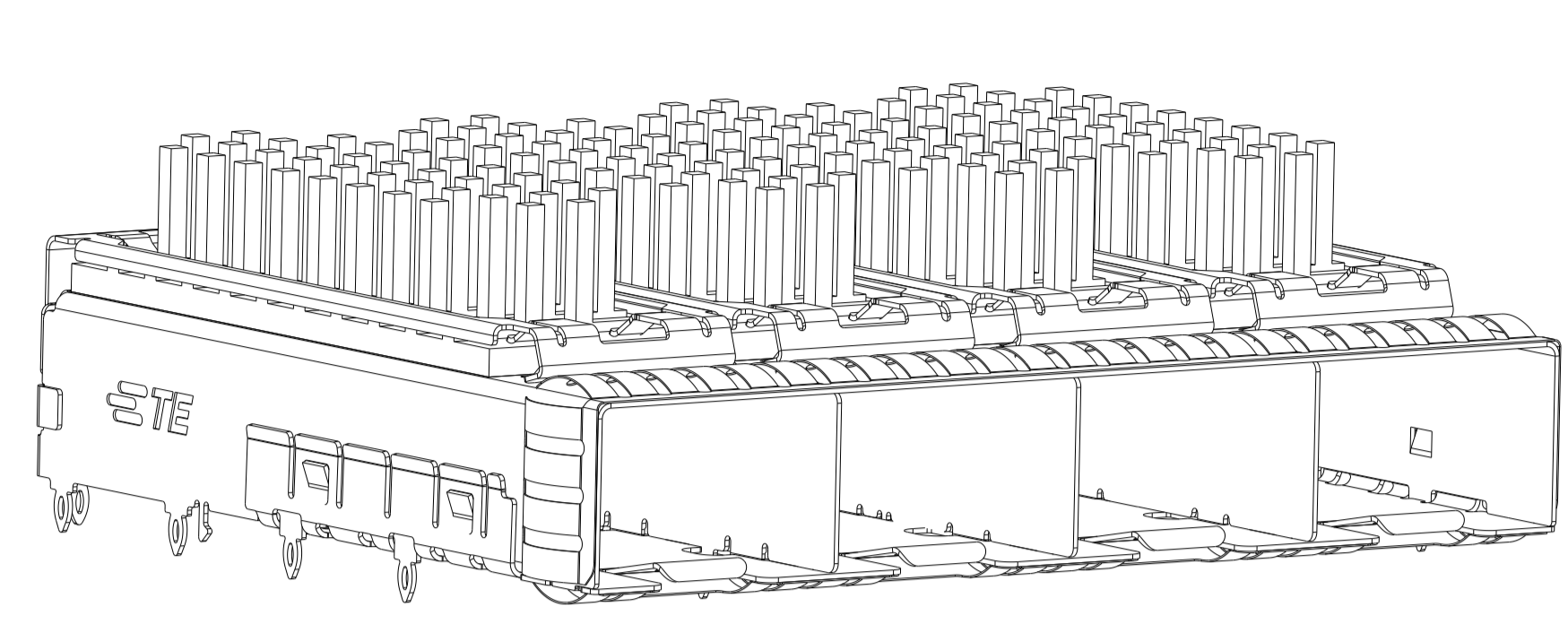

2149730-1,2,3,4,5
 FINISHED ASSEMBLY WITH
 PIN TYPE HEAT SINK

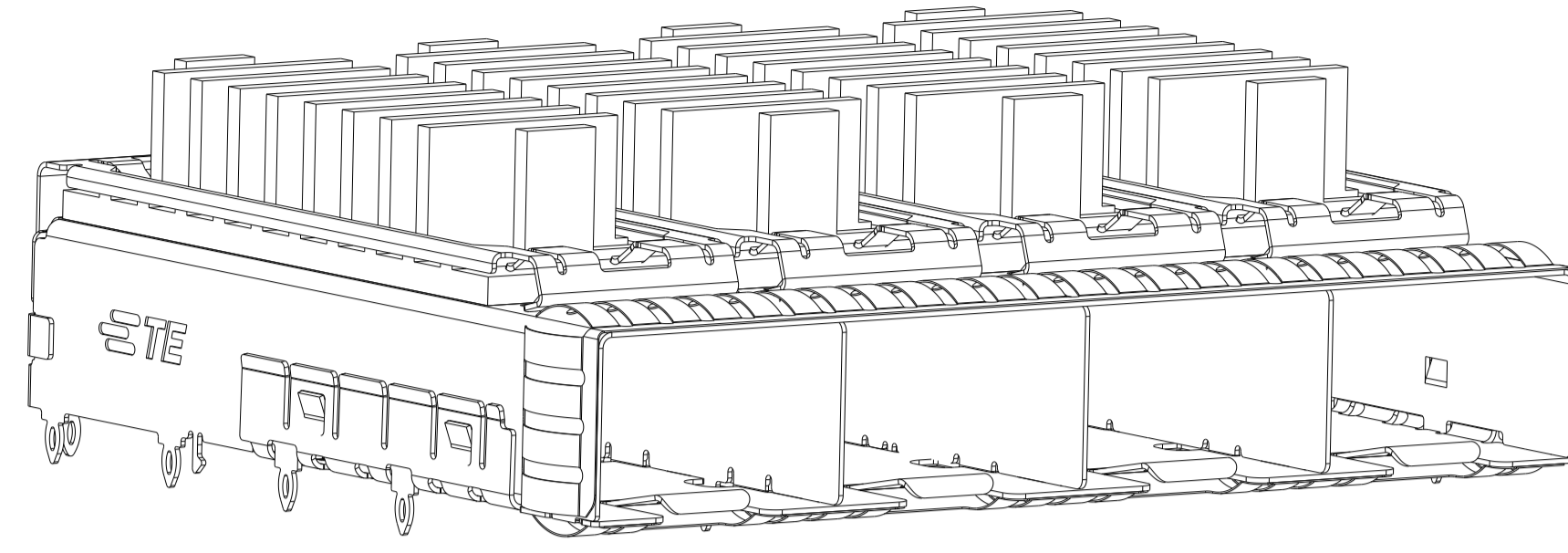

2149730-6,7,8,9,10
 FINISHED ASSEMBLY WITH
 FIN TYPE HEAT SINK

- 1. MATERIAL:
 CAGE ASSEMBLY: 0.25mm THICK NICKEL SILVER ALLOY
 HEATSINK CLIP: STAINLESS STEEL
 HEATSINK: ALUMINUM
- 2. FINISH:
 EMI SPRINGS: MINIMUM OF 0.8um TIN PLATE OVER A MINIMUM OF 0.8um NICKEL UNDERPLATE.
 NON-PLATED EDGES PERMISSIBLE.
 HEATSINK: ELECTROLESS NICKEL
 HEATSINK CLIP: PASSIVATE
- 3. PADS AND VIAS CHASSIS GROUND.
- 4. DATUM AND BASIC DIMENSION ESTABLISHED BY CUSTOMER.
- 5. MATES WITH SFP MSA COMPLIANT TRANSCEIVERS.
- 6. INTERPRETATION OF DATUM REFERENCE FRAME IN ACCORDANCE WITH SECT 4.4.1.1 OF ASME Y14.5M-1994.
- 7. REFERENCE APPLICATION SPEC. 114-13120, HOLE A, FOR RECOMMENDED DRILL HOLE DIAMETER AND PLATING THICKNESS.
- 8. REFERENCE APPLICATION SPEC. 114-13120, HOLE B, FOR RECOMMENDED DRILL HOLE DIAMETER AND PLATING THICKNESS.
- 9. HOLE PATTERN REPEATS FOR EACH PORT. SPACING BETWEEN PORTS IS 14.25mm.
- 10. MINIMUM PC BOARD THICKNESS:
 SINGLE SIDED = 1.50mm
 DOUBLE SIDED = 2.25mm
- 11. CERTAIN MATING TRANSCEIVERS MAY REQUIRE ADDITIONAL PCB THICKNESS THAT WOULD BE DETERMINED BY THE CUSTOMER.
- 12. PRODUCT COMPLIES WITH SPECIFICATION SFF-8433 IMPROVED PLUGGABLE FROM FACTOR FOR SFP+ GANGED CAGES.
- 13. DIMENSION APPLIES PRIOR TO INSERTION OF SFP MODULE

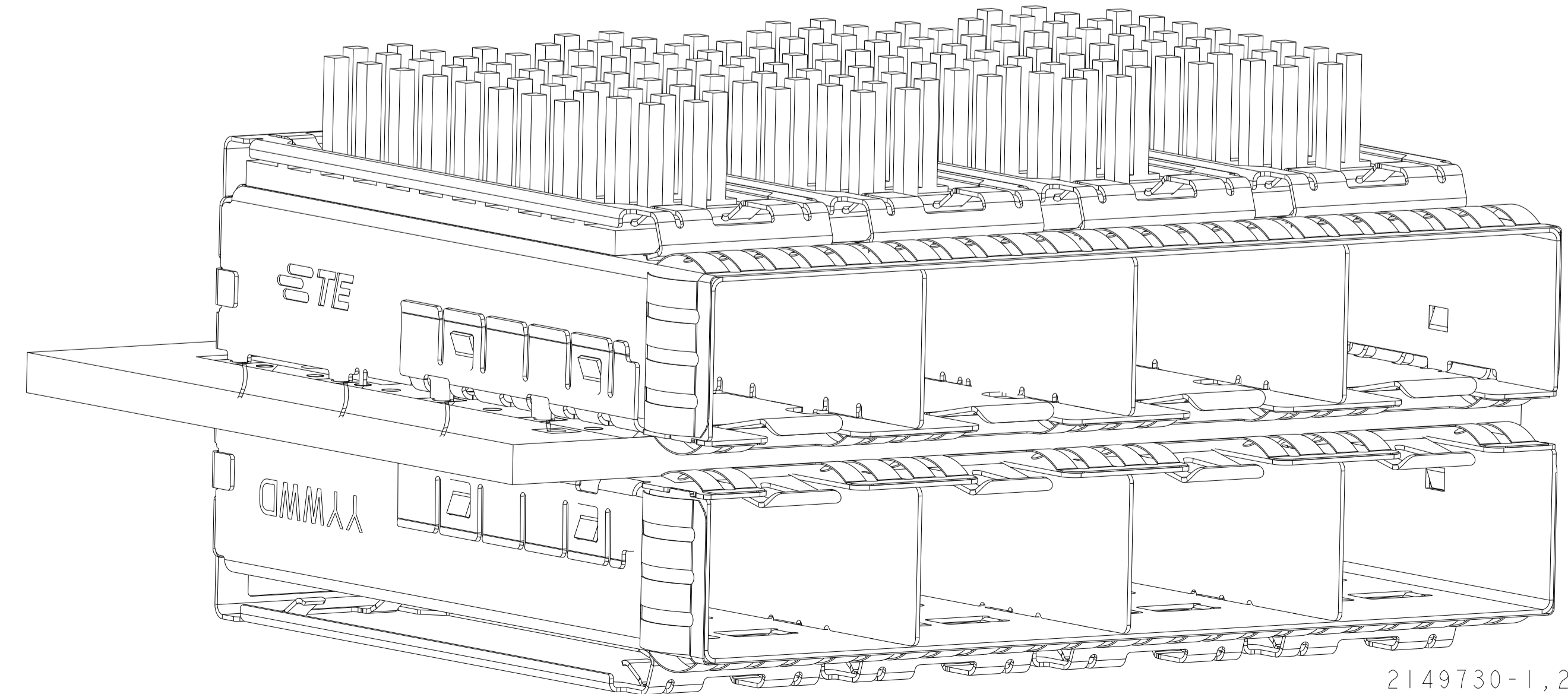
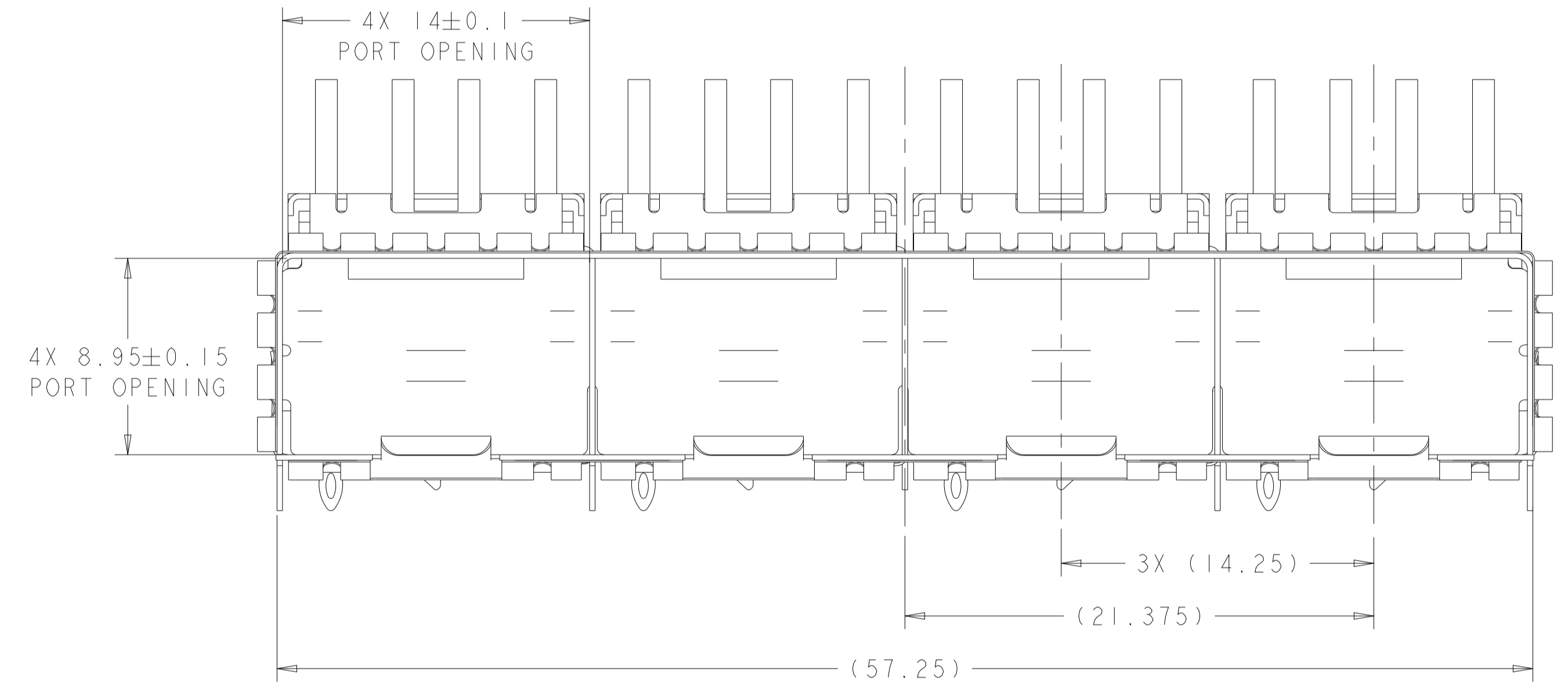
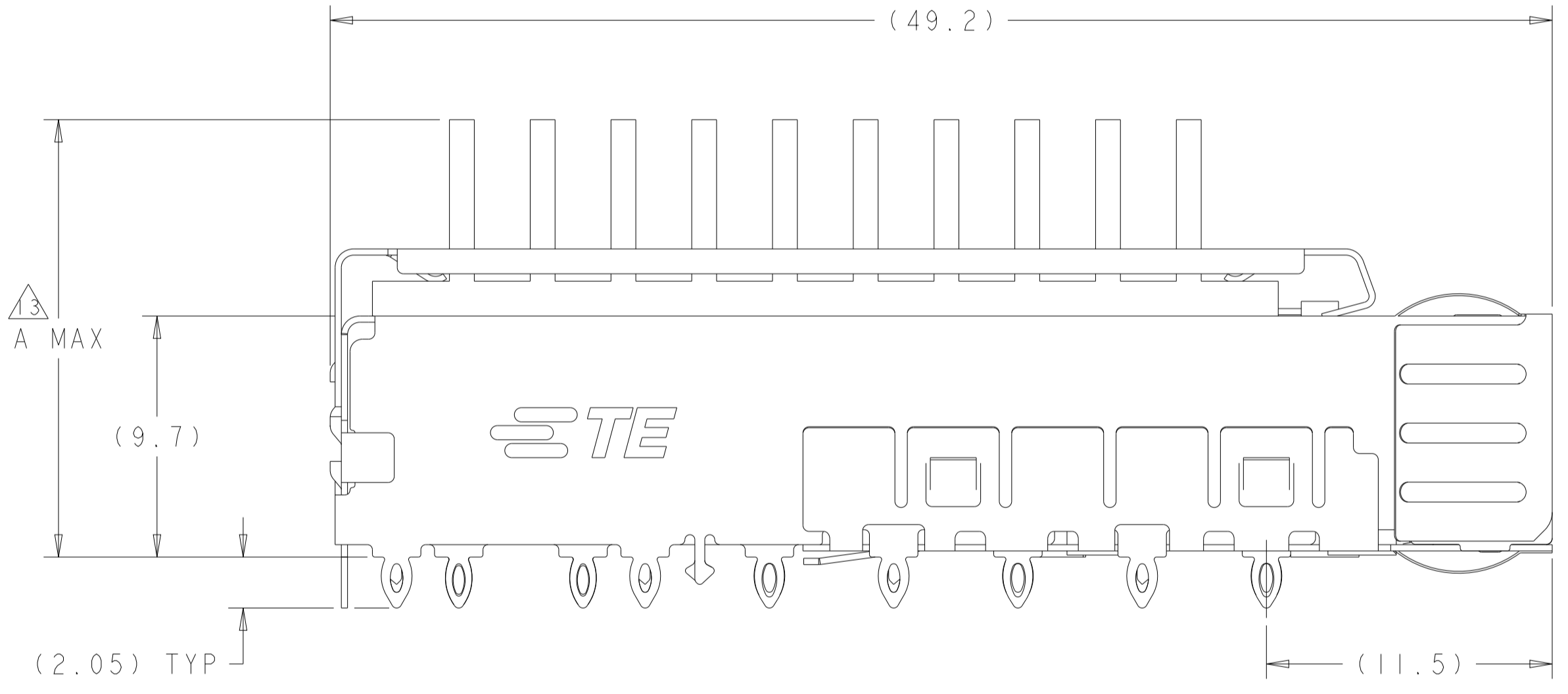

2149730-1,2,3,4,5
 MOUNTED BELLY TO BELLY ON PCB
 SCALE 4:1

FIN TYPE	W/O INSULATING TAPE	N/A	CUSTOMIZED	1-2149730-4
FIN TYPE	W/O INSULATING TAPE	N/A	CUSTOMIZED	1-2149730-3
PIN TYPE	W/O INSULATING TAPE	N/A	CUSTOMIZED	1-2149730-2
PIN TYPE	W/O INSULATING TAPE	N/A	CUSTOMIZED	1-2149730-1
FIN TYPE	W/ INSULATING TAPE	22.5	NETWORKING, TALL	2149730-10
FIN TYPE	W/O INSULATING TAPE	22.5	NETWORKING, TALL	2149730-9
FIN TYPE	W/O INSULATING TAPE	15.5	SAN	2149730-8
FIN TYPE	W/O INSULATING TAPE	13.2	PCI	2149730-7
FIN TYPE	W/O INSULATING TAPE	18.1	NETWORKING, SHORT	2149730-6
PIN TYPE	W/ INSULATING TAPE	22.5	NETWORKING, TALL	2149730-5
PIN TYPE	W/O INSULATING TAPE	22.5	NETWORKING, TALL	2149730-4
PIN TYPE	W/O INSULATING TAPE	15.5	SAN	2149730-3
PIN TYPE	W/O INSULATING TAPE	13.2	PCI	2149730-2
PIN TYPE	W/O INSULATING TAPE	18.1	NETWORKING, SHORT	2149730-1
HEAT SINK TYPE	DESCRIPTION	A MAX	APPLICATION	PART NUMBER

THIS DRAWING IS A CONTROLLED DOCUMENT. OWN: M. SCHMITT 23AUG2010
 CHK: M. SCHMITT 23AUG2010
 DIMENSIONS: mm TOLERANCES UNLESS OTHERWISE SPECIFIED:
 0 PLC ±0.1
 1 PLC ±0.1
 2 PLC ±0.1
 3 PLC ±0.1
 4 PLC ±0.1
 ANGLES ±1°
 MATERIAL: FINISH: 2

APVD: B. WERTZ 23AUG2010
 PRODUCT SPEC: 108-2364
 APPLICATION SPEC: 114-13120
 WEIGHT: -

Customer Drawing

NAME: SFP+ ENHANCED 1X4 CAGE ASSEMBLY PRESS FIT, EXTERNAL EMI SPRINGS WITH HEATSINK
 SIZE: CAGE CODE DRAWING NO: 100779
 DRAWING NO: 2149730
 RESTRICTED TO: -

SCALE: 2:1 SHEET 1 OF 9 REV: A7

LOC	DIST	REVISIONS					
GP	00	P	LYR	DESCRIPTION	DATE	OWN	APVD
		-		SEE SHEET 1			

WITH INSULATING TAPE

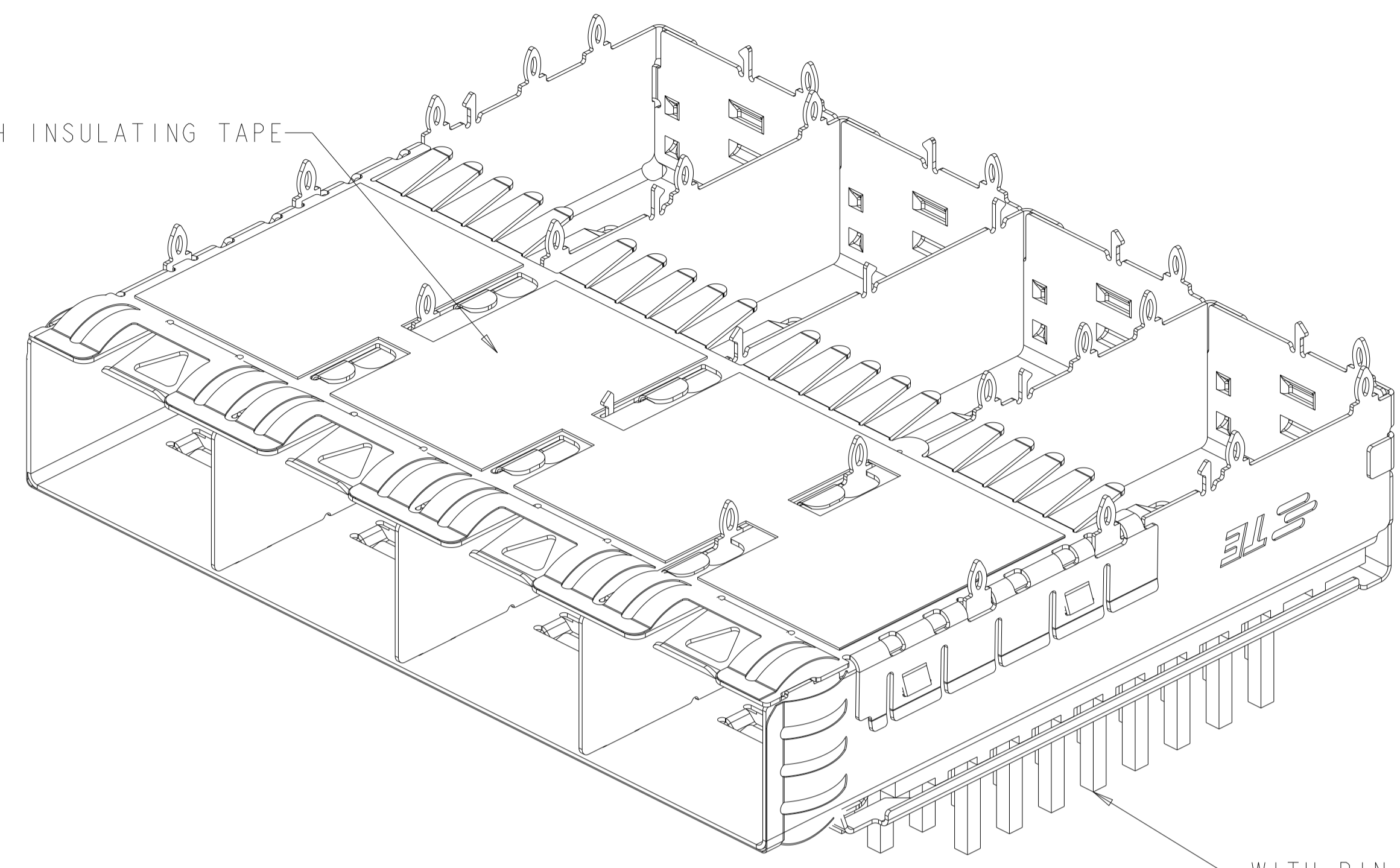

WITH PIN TYPE HEAT SINK

2149730-5 AS SHOWN WITH INSULATING TAPE, WITH PIN TYPE HEAT SINK

WITHOUT INSULATING TAPE

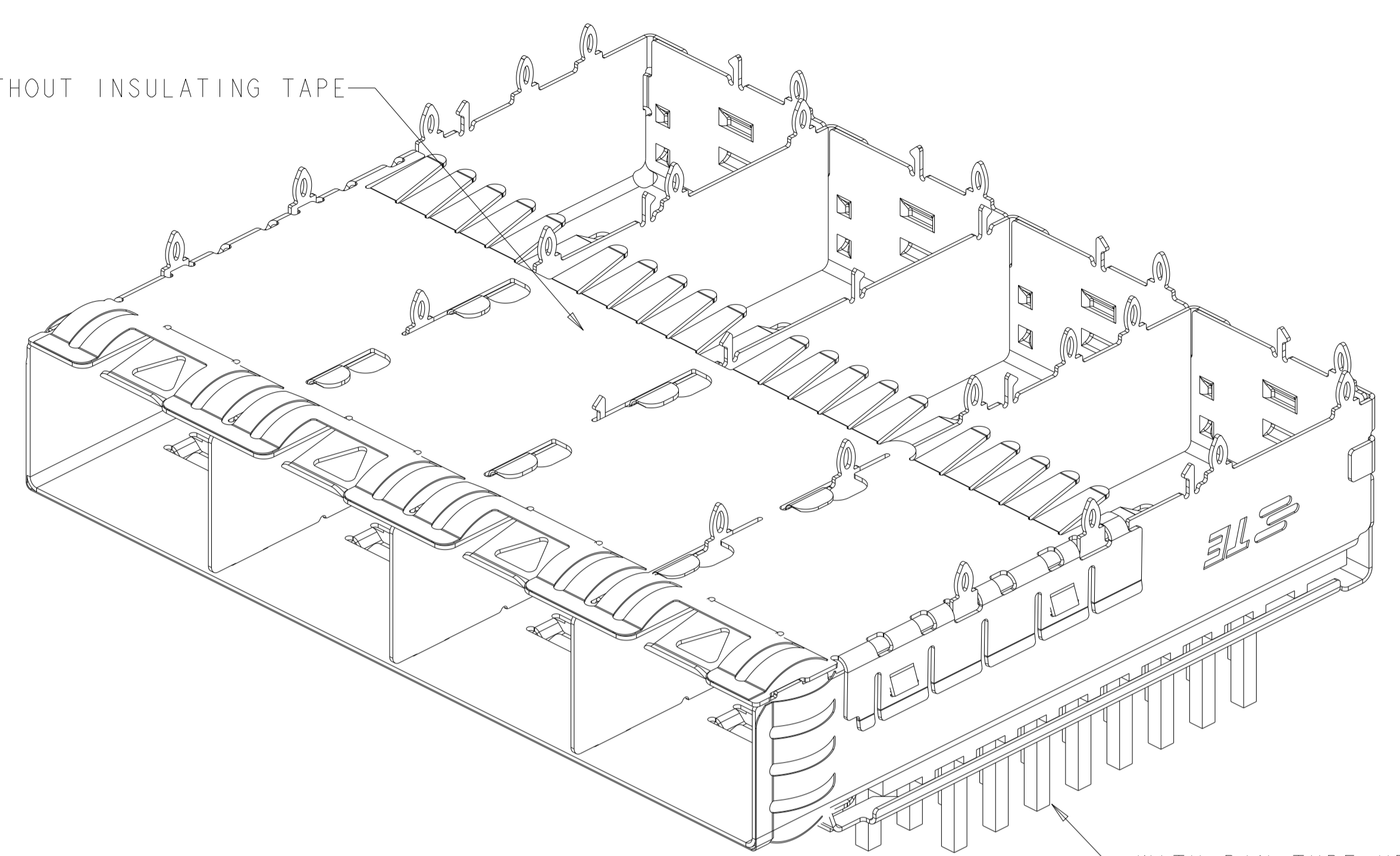

WITH PIN TYPE HEAT SINK

2149730-1,2,3,4 AS SHOWN WITHOUT INSULATING TAPE, WITH PIN TYPE HEAT SINK

WITH INSULATING TAPE

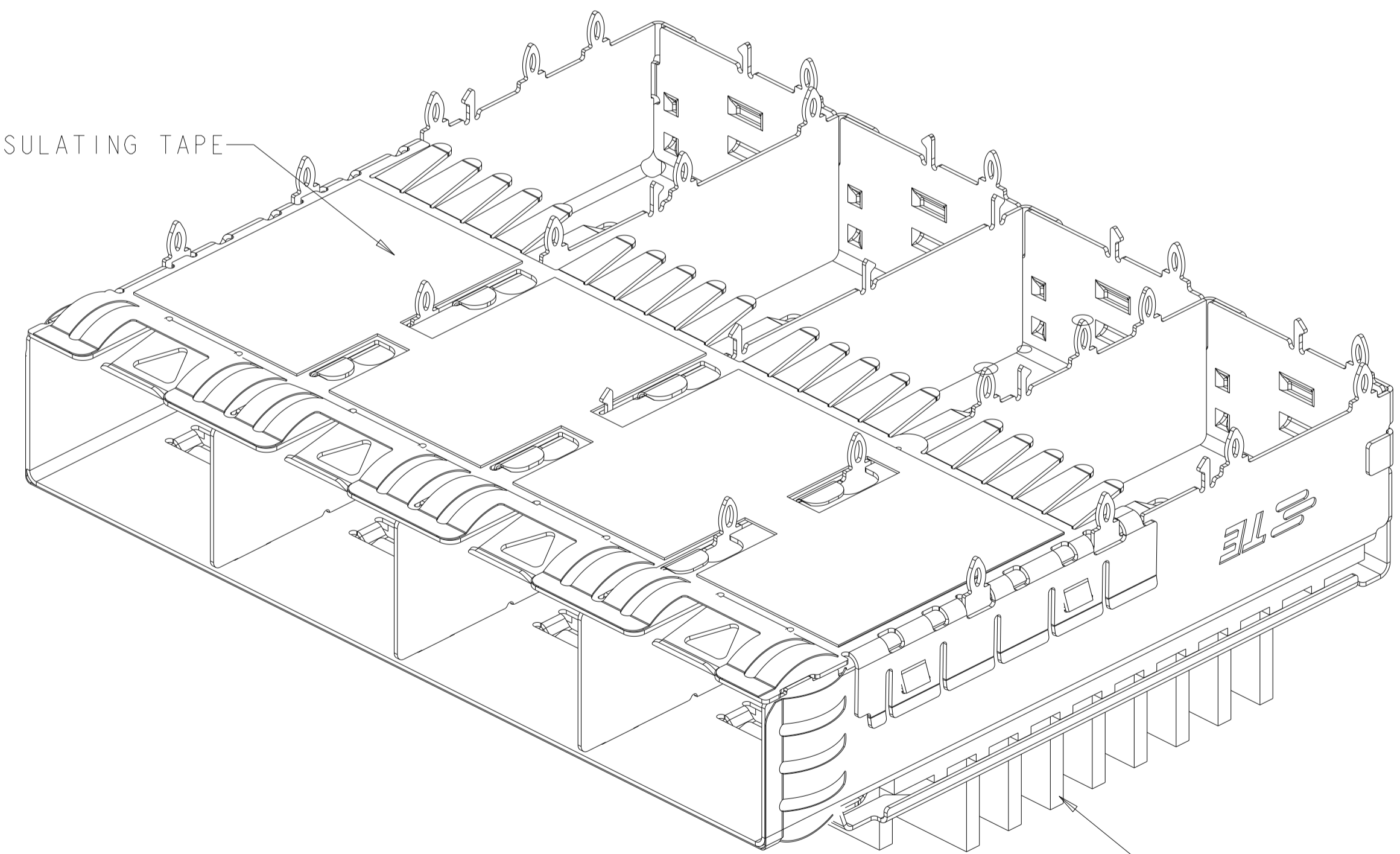

WITH FIN TYPE HEAT SINK

2149730-10 AS SHOWN WITH INSULATING TAPE, WITH FIN TYPE HEAT SINK

WITHOUT INSULATING TAPE

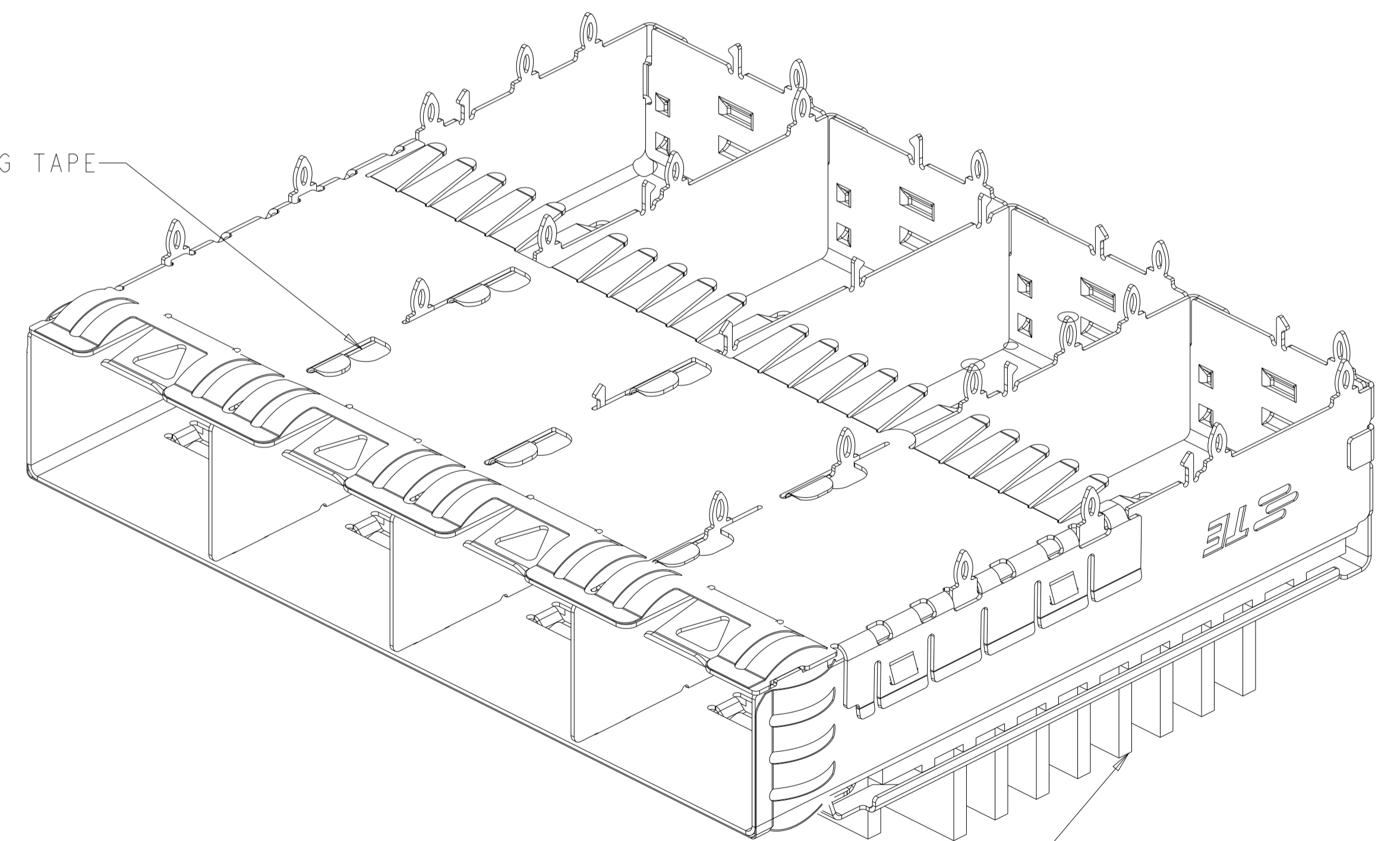

WITH FIN TYPE HEAT SINK

2149730-6,7,8,9 AS SHOWN WITHOUT INSULATING TAPE, WITH FIN TYPE HEAT SINK

THIS DRAWING IS A CONTROLLED DOCUMENT.		OWN M. SCHMITT 23AUG2010	TE Connectivity
DIMENSIONS: mm		CHK M. SCHMITT 23AUG2010	
TOLERANCES UNLESS OTHERWISE SPECIFIED:		APVD B. WERTZ 23AUG2010	NAME
0 PLC	±0.1	PRODUCT SPEC	SFP+ ENHANCED 1X4 CAGE ASSEMBLY
1 PLC	±0.1	APPLICATION SPEC	PRESS FIT, EXTERNAL EMI SPRINGS
2 PLC	±0.1	SIZE	WITH HEATSINK
3 PLC	±0.1	108-2364	
4 PLC	±0.1	114-13120	
ANGLES	±1°	WEIGHT	
FINISH		Customer Drawing	
		SCALE 2:1	SHEET 2 OF 9
			REV A7

LOC		DIST		REVISIONS			
P	LYN	DESCRIPTION	DATE	OWN	APVD		
-	-	SEE SHEET 1	-	-	-		

1-2149730-1 AS SHOWN
 UNMARKED SAME AS 2149730-1

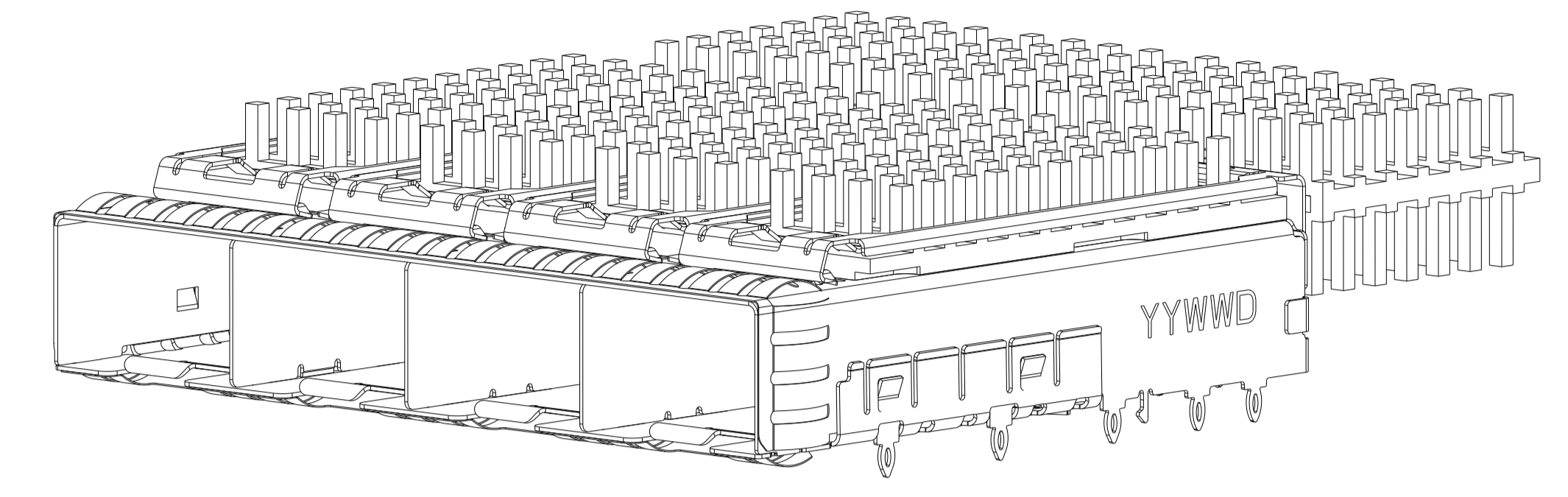
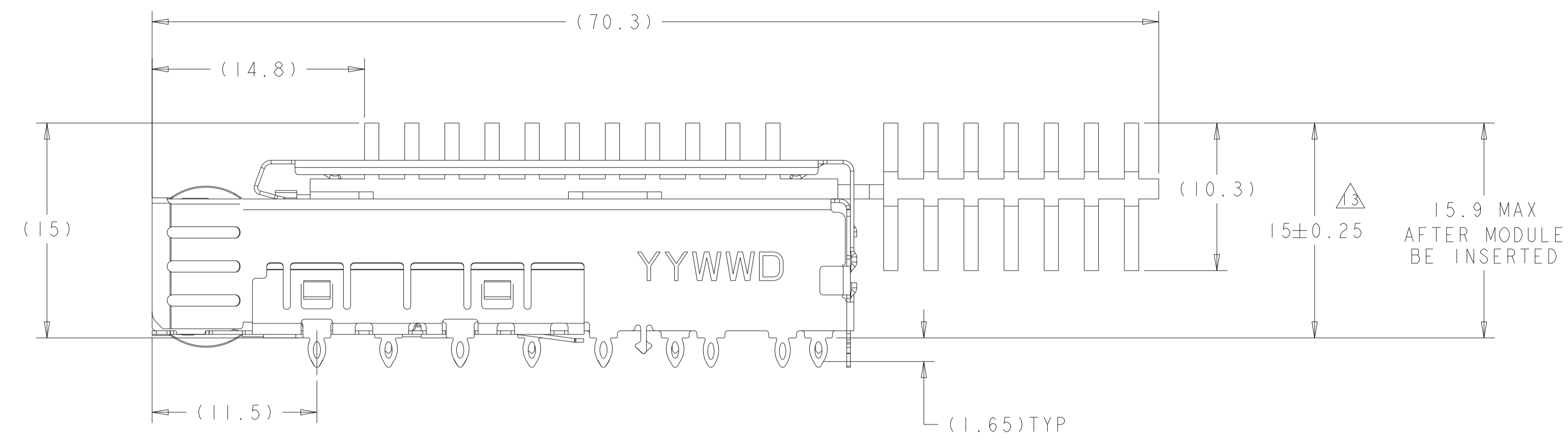

1-2149730-1 3D VIEW
 SCALE 3:1

1-2149730-2 AS SHOWN
 UNMARKED SAME AS 2149730-1

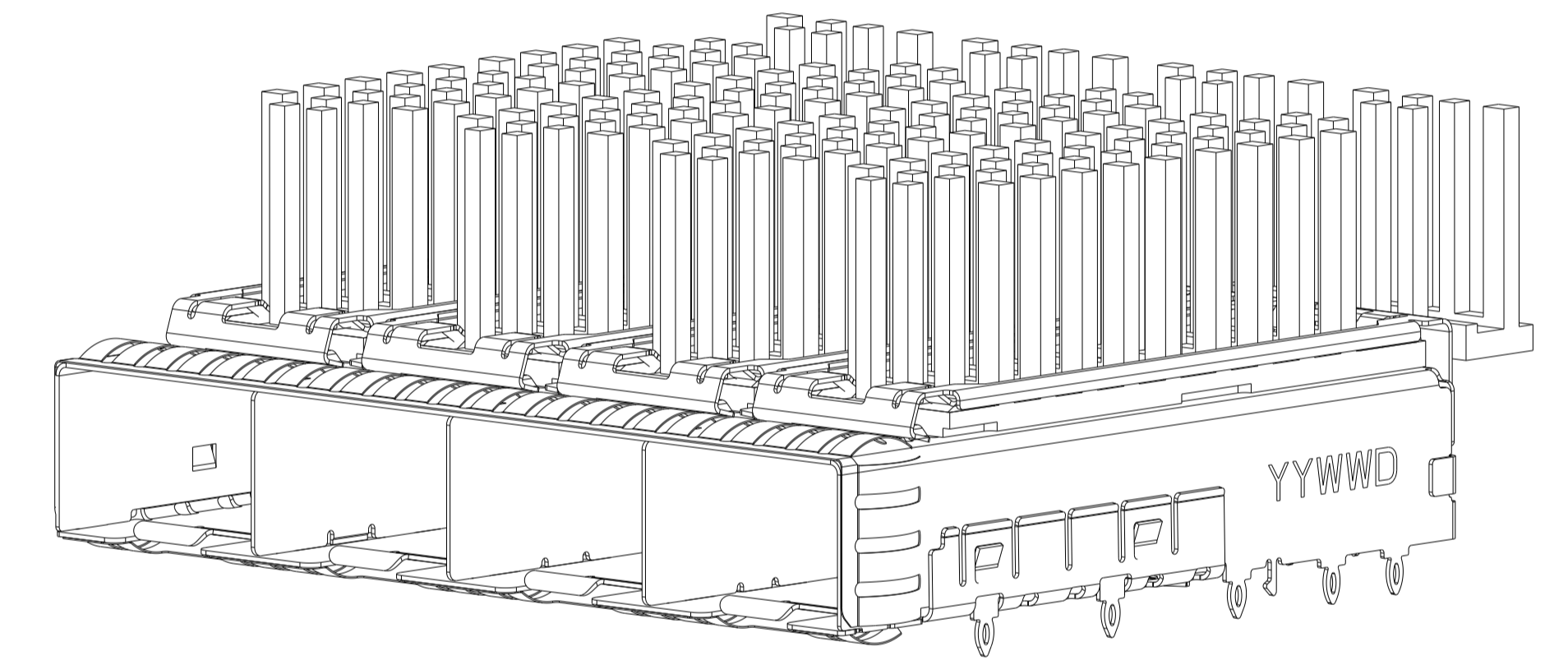
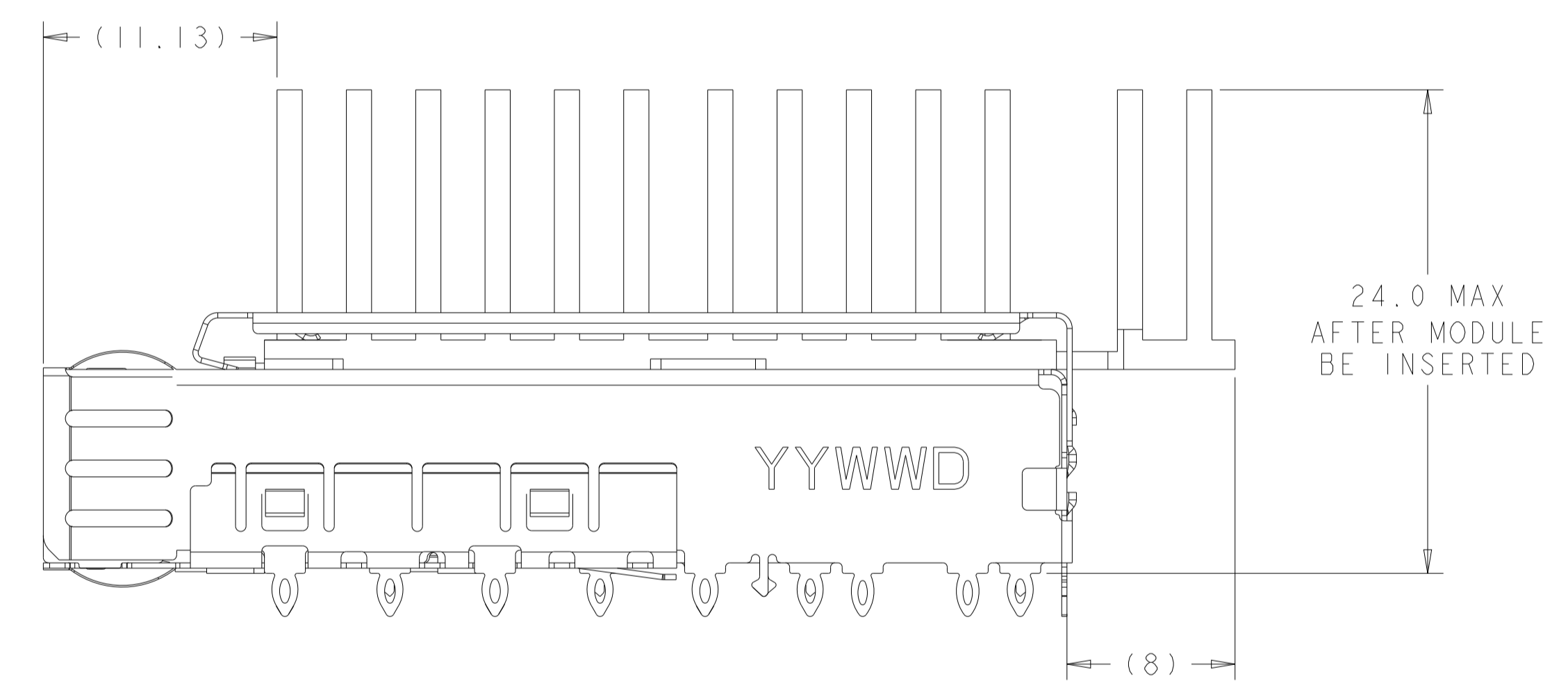

1-2149730-2 3D VIEW
 SCALE 3:1

1-2149730-3 AS SHOWN
 UNMARKED SAME AS 2149730-1

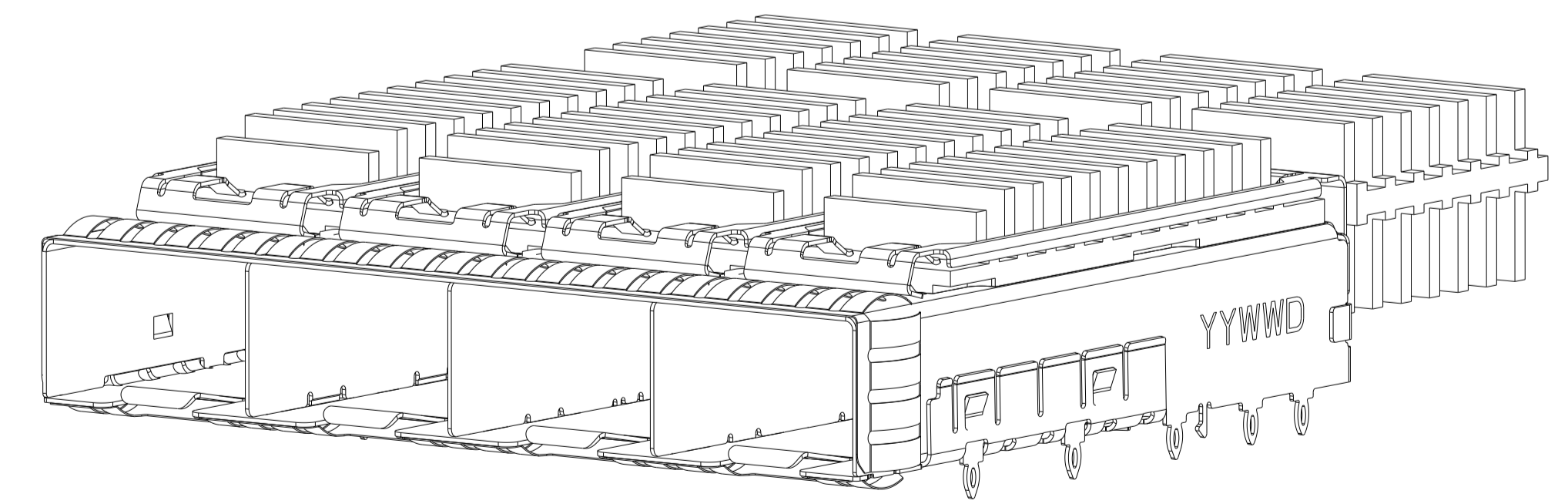
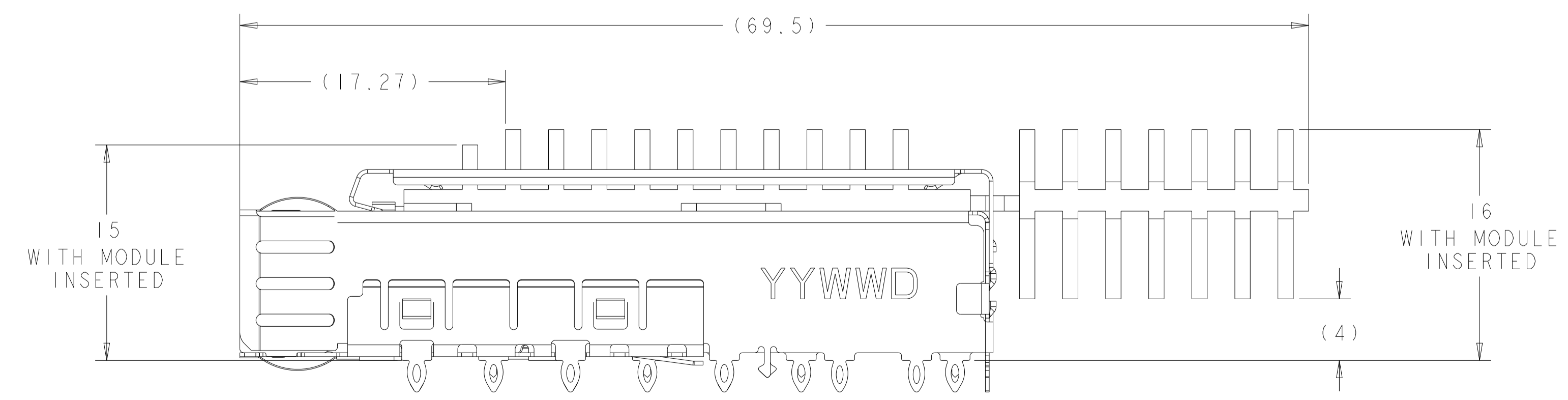

1-2149730-3 3D VIEW
 SCALE 3:1

SCALE 4:1

THIS DRAWING IS A CONTROLLED DOCUMENT.		OWN M. SCHMITT 23AUG2010	TE Connectivity
DIMENSIONS: mm		CHK M. SCHMITT 23AUG2010	
TOLERANCES UNLESS OTHERWISE SPECIFIED:		APVD B. WERTZ 23AUG2010	NAME SFP+ ENHANCED 1X4 CAGE ASSEMBLY PRESS FIT, EXTERNAL EMI SPRINGS WITH HEATSINK
0 PLC ±0.1		PRODUCT SPEC 108-2364	RESTRICTED TO
1 PLC ±0.1		APPLICATION SPEC 114-13120	SIZE CAGE CODE DRAWING NO A100779C=2149730
2 PLC ±0.1		WEIGHT	SCALE 2:1 SHEET 3 OF 9 REV A7
3 PLC ±0.1		MATERIAL FINISH	Customer Drawing
4 PLC ±0.1			
ANGLES ±1°			

LOC	DIST	REVISIONS					
		P	LTN	DESCRIPTION	DATE	DMN	APVD
GP	00	-	-	SEE SHEET 1	-	-	-

1-2149730-4 AS SHOWN
 UNMARKED SAME AS 2149730-1

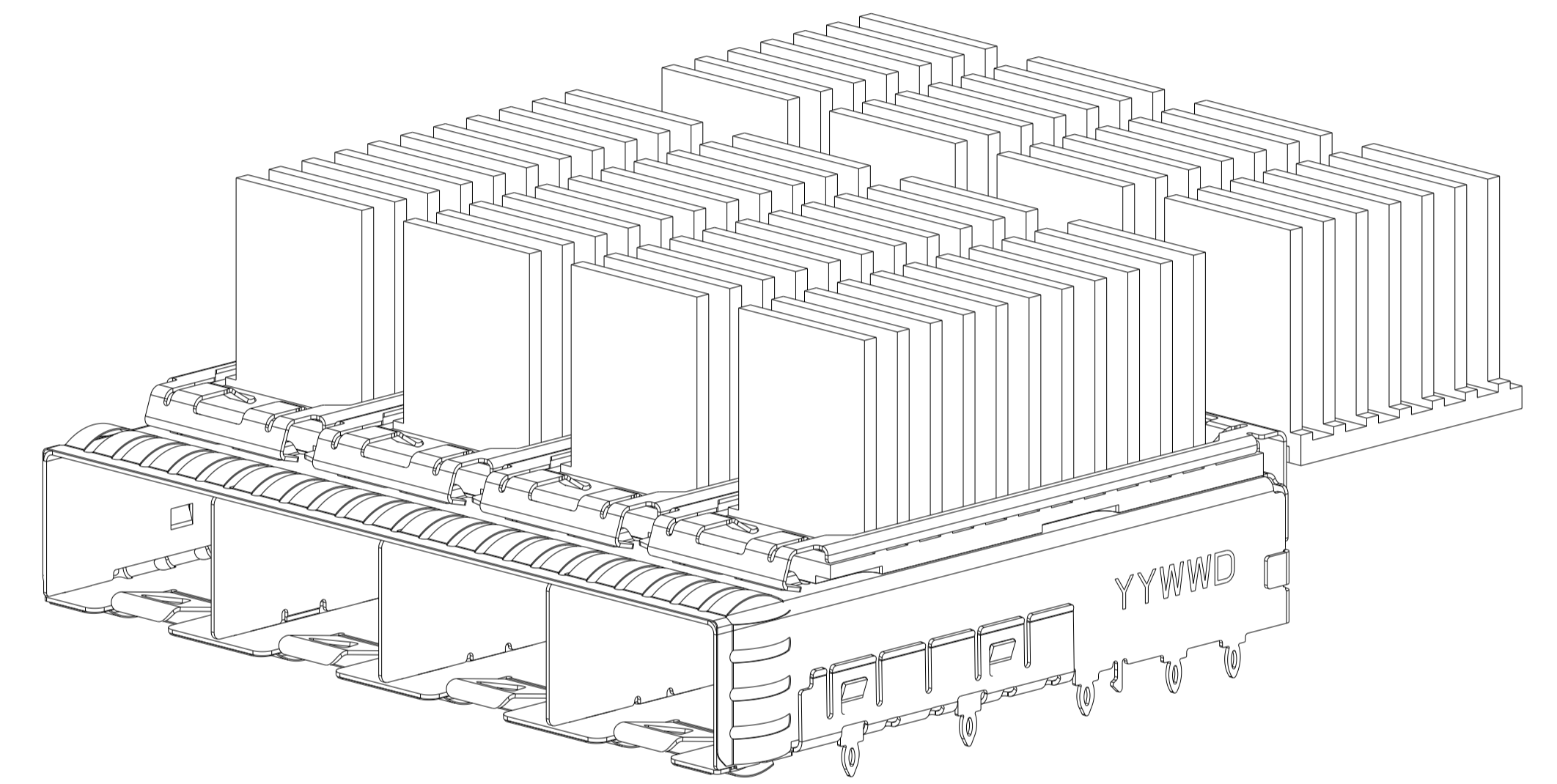
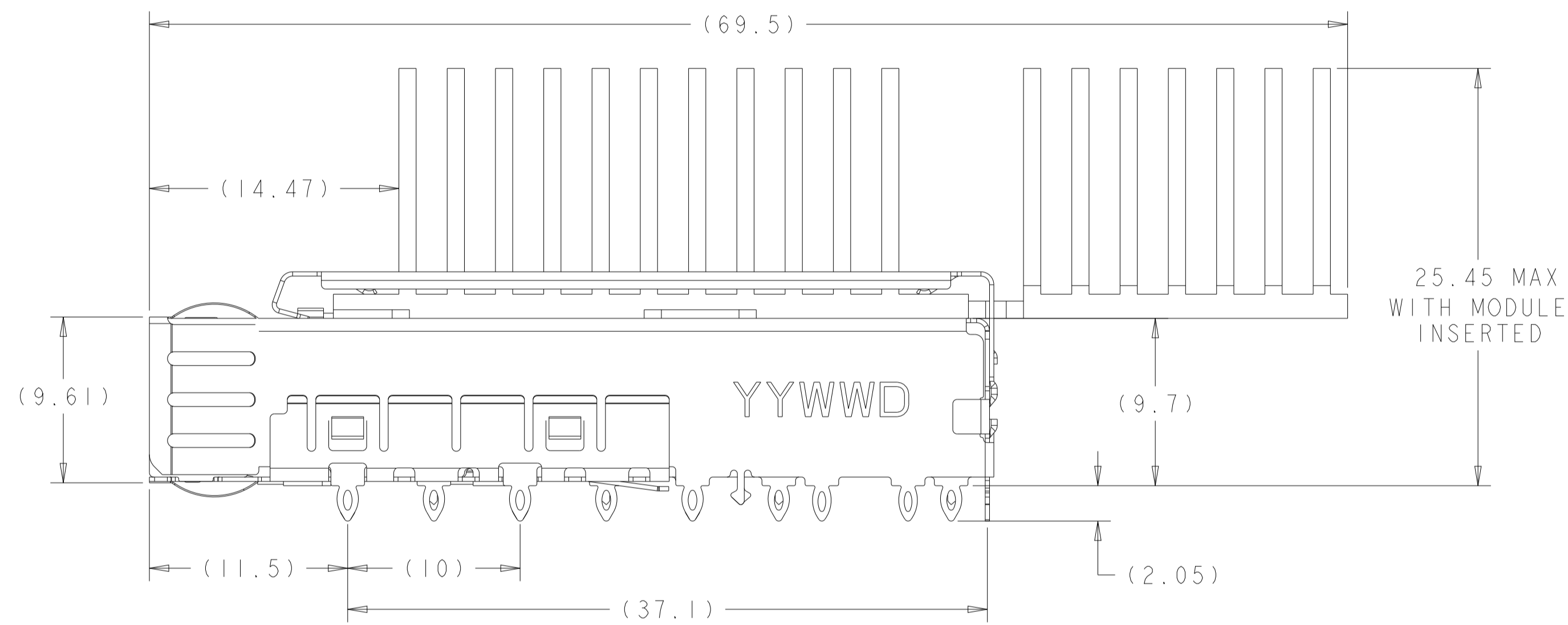

1-2149730-4 AS SHOWN
 UNMARKED SAME AS 2149730-1

THIS DRAWING IS A CONTROLLED DOCUMENT.		DMN M. SCHMITT 23AUG2010	STE TE Connectivity
DIMENSIONS: mm		CHK M. SCHMITT 23AUG2010	
TOLERANCES UNLESS OTHERWISE SPECIFIED:		APVD B. WERTZ 23AUG2010	NAME
0 PLC ±0.1		PRODUCT SPEC	SFP+ ENHANCED 1X4 CAGE ASSEMBLY
1 PLC ±0.1		APPLICATION SPEC	PRESS FIT, EXTERNAL EMI SPRINGS
2 PLC ±0.1		114-13120	WITH HEATSINK
3 PLC ±0.1		WEIGHT	RESTRICTED TO
4 PLC ±0.1		Customer Drawing	A100779C=2149730
ANGLES ±1°		SCALE 2:1	SHEET 4 OF 9
FINISH			REV A7

LOC	DIST	REV	DATE	BY	APPV
GP	00				

REVISIONS			
NO.	DESCRIPTION	DATE	BY
-	SEE SHEET 1	-	-

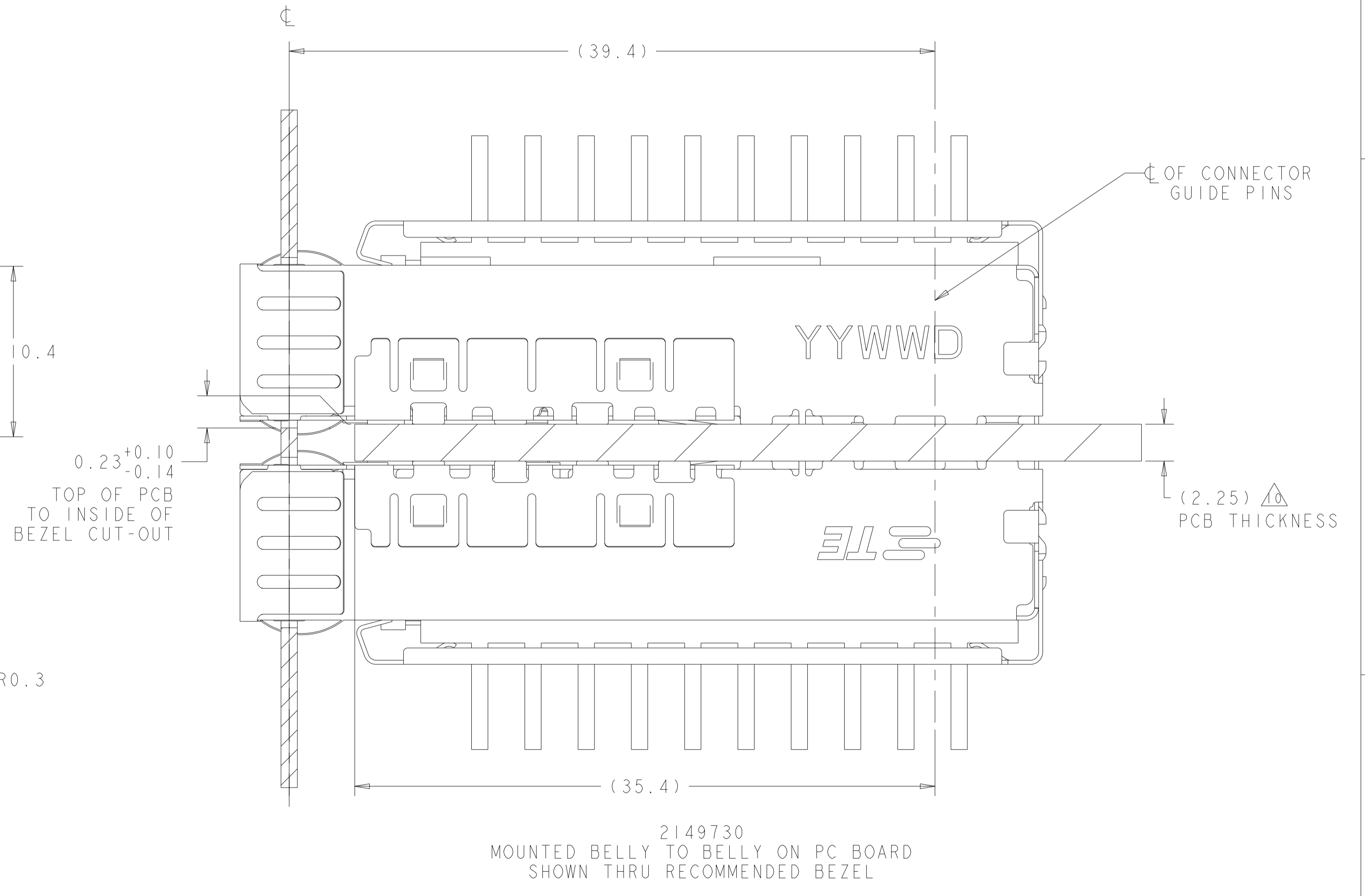
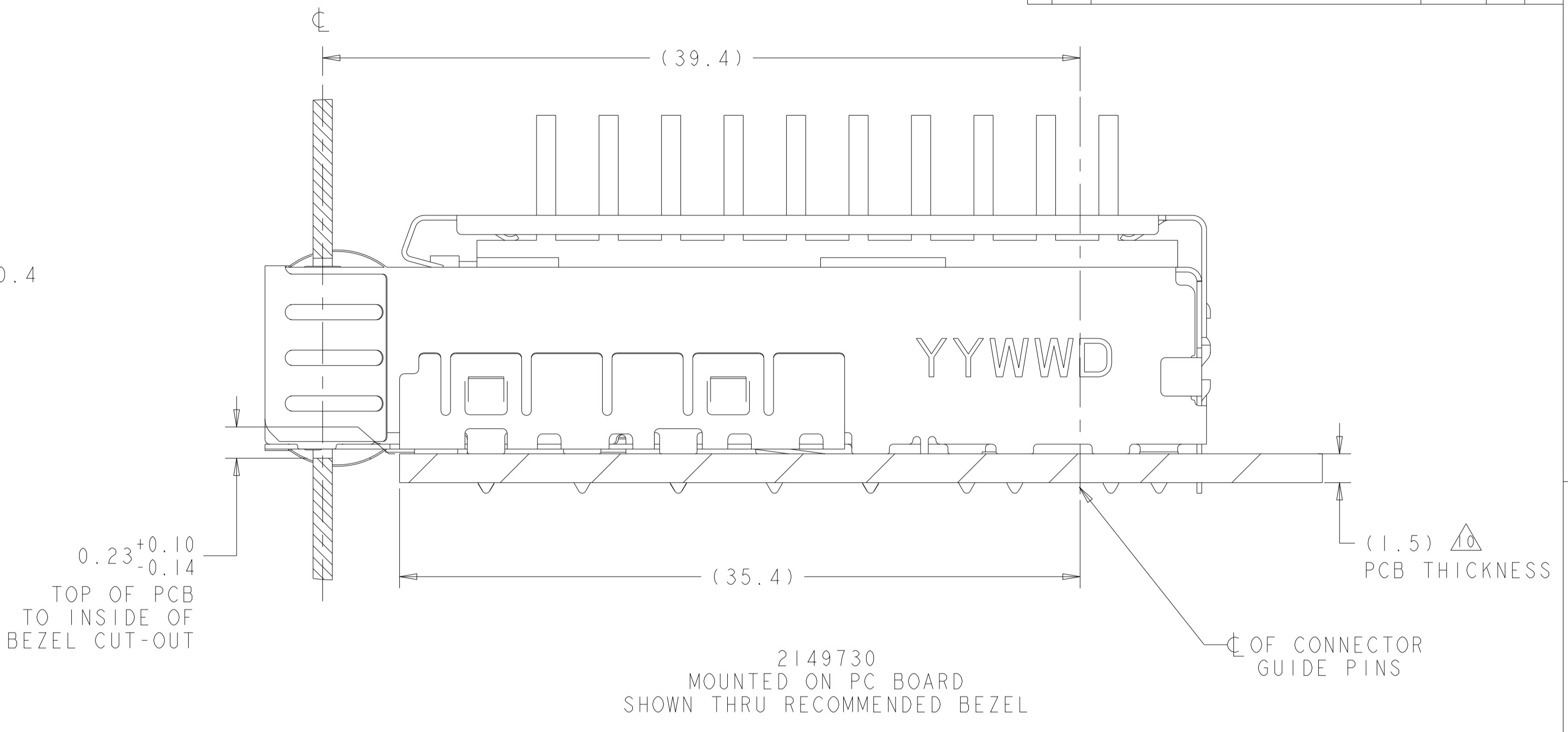
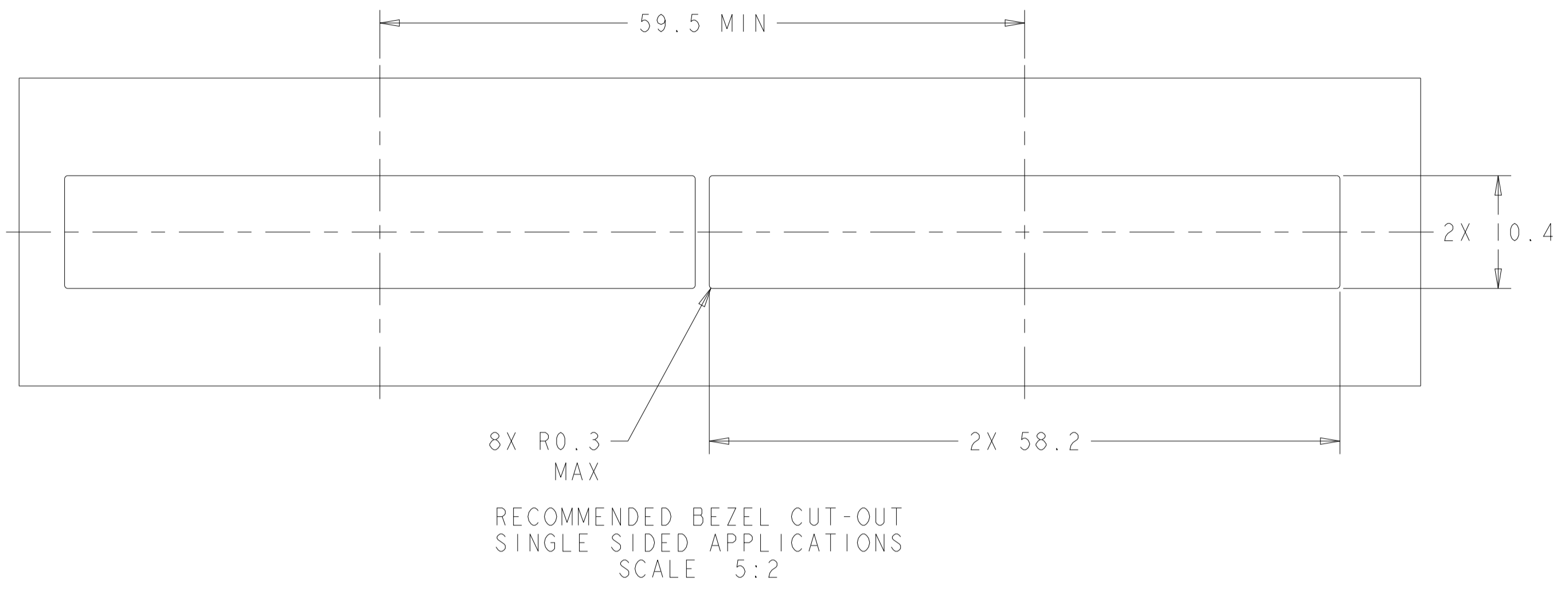

THIS DRAWING IS A CONTROLLED DOCUMENT.		OWN M. SCHMITT 23AUG2010	 TE Connectivity
DIMENSIONS: mm		CHK M. SCHMITT 23AUG2010	
TOLERANCES UNLESS OTHERWISE SPECIFIED:		APVD B. WERTZ 23AUG2010	NAME
0 PLC	±0.1	PRODUCT SPEC	SFP+ ENHANCED 1X4 CAGE ASSEMBLY
1 PLC	±0.1	APPLICATION SPEC	PRESS FIT, EXTERNAL EMI SPRINGS
2 PLC	±0.1	108-2364	WITH HEATSINK
3 PLC	±0.1	114-13120	RESTRICTED TO
4 PLC	±0.1	WEIGHT	A1 00779 C=2149730
ANGLES	±1°	Customer Drawing	SCALE 2:1 SHEET 5 OF 9 REV A7
FINISH			

LOC	DIST	REVISIONS			
P	LYR	DESCRIPTION	DATE	OWN	APVD
GP	00	SEE SHEET 1			

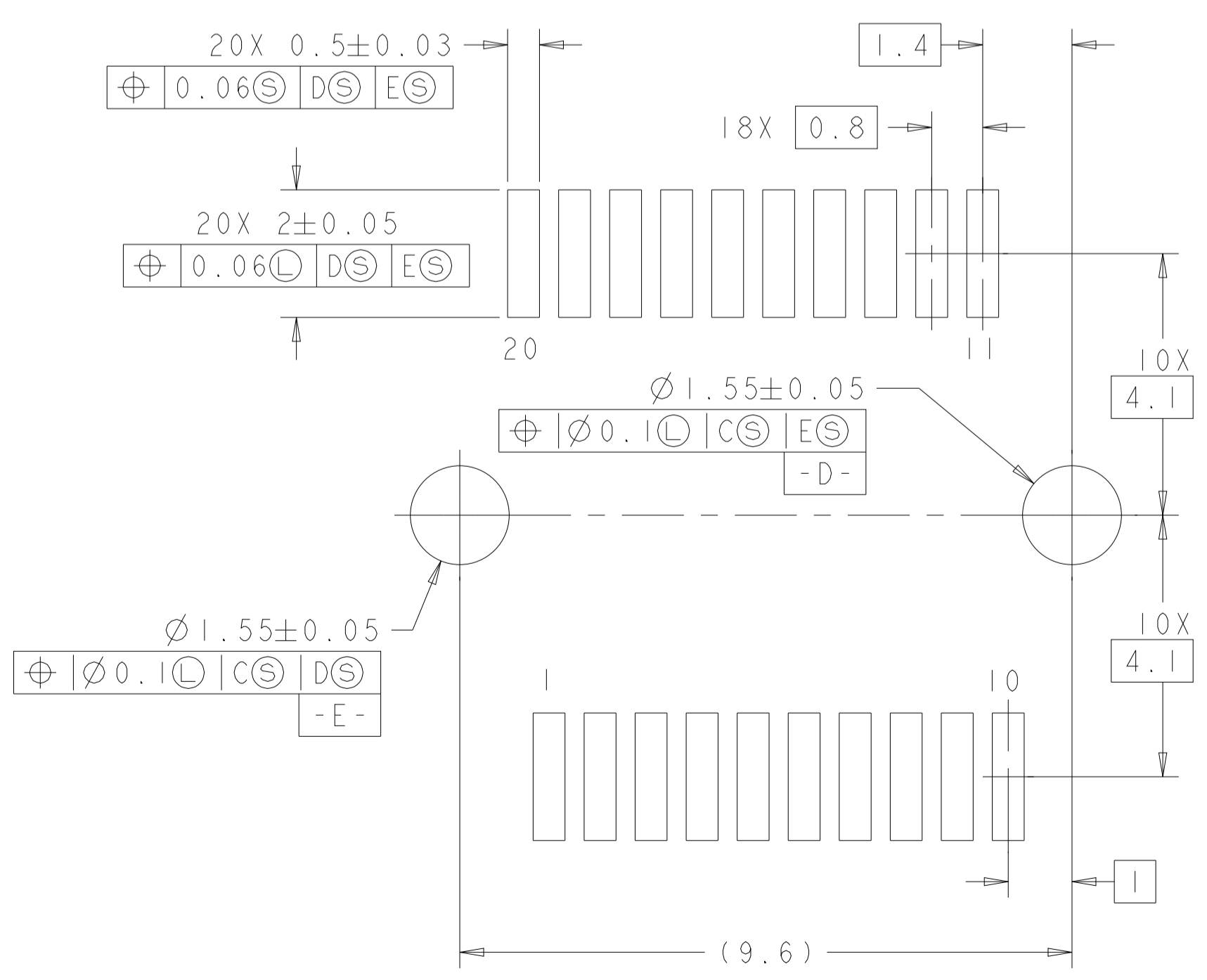
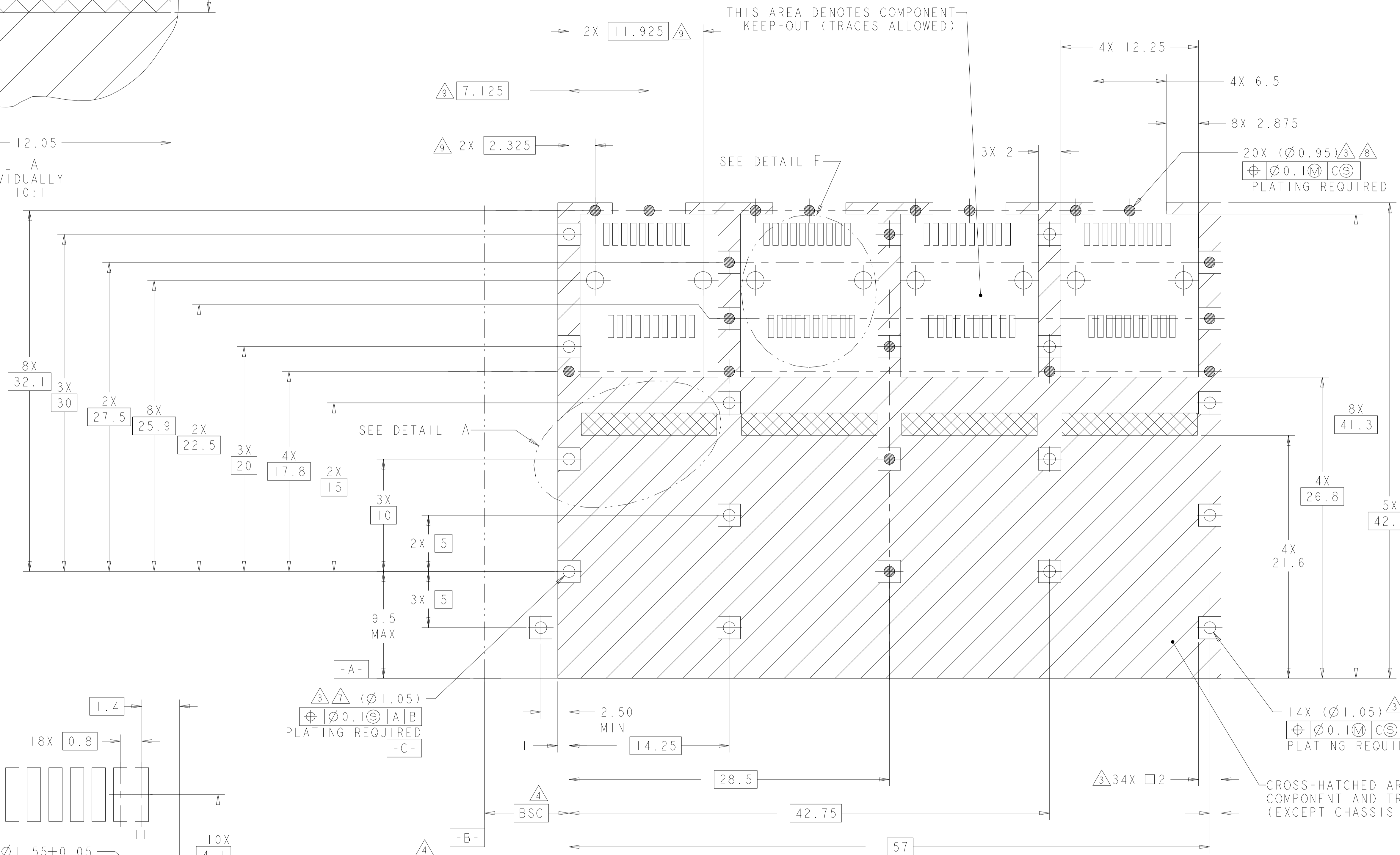
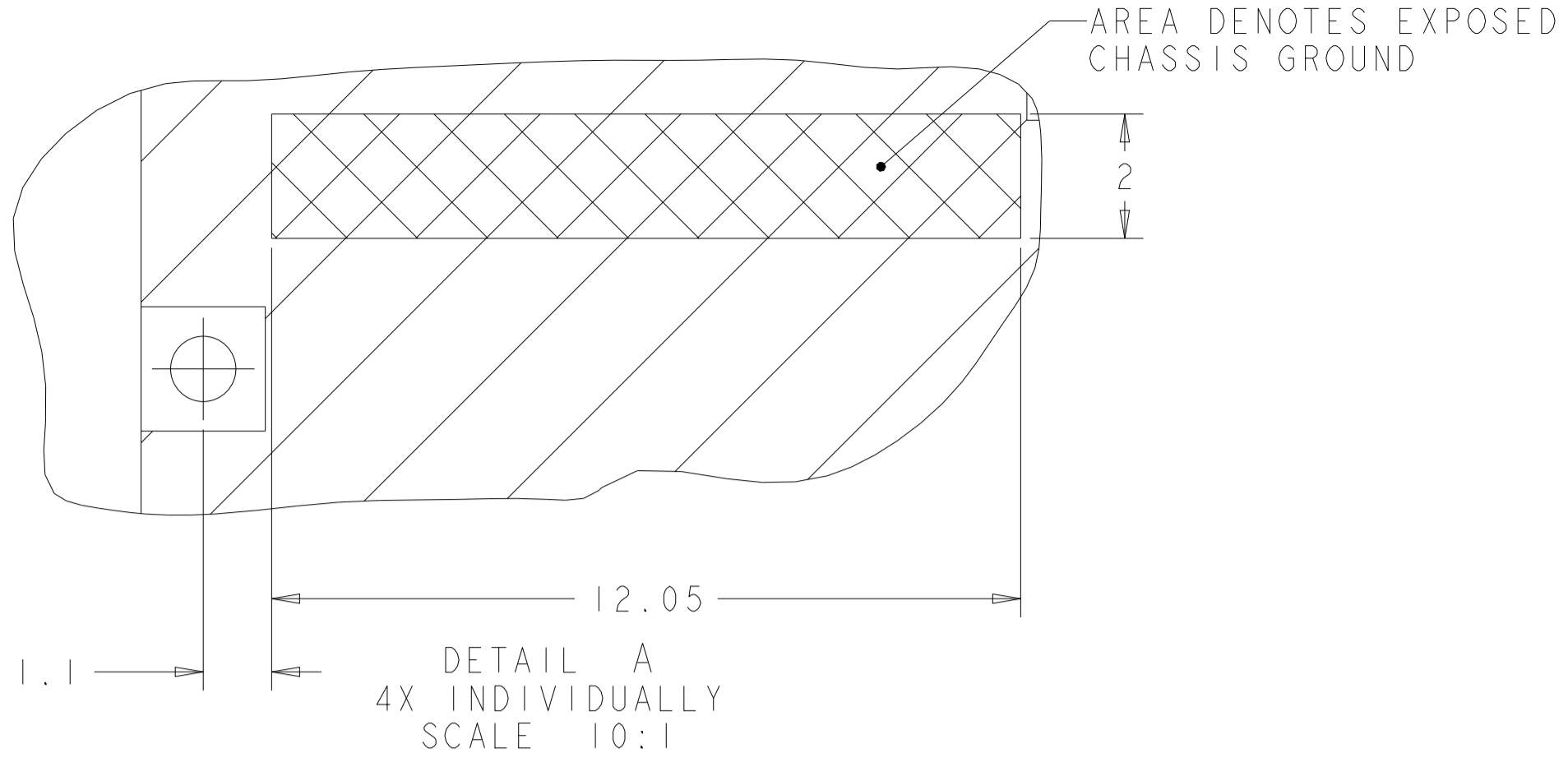

THIS DRAWING IS A CONTROLLED DOCUMENT.		OWN: M. SCHMITT 23AUG2010	TE Connectivity
DIMENSIONS: mm		CHK: M. SCHMITT 23AUG2010	
TOLERANCES UNLESS OTHERWISE SPECIFIED:		APVD: B. WERTZ 23AUG2010	NAME: SFP+ ENHANCED 1X4 CAGE ASSEMBLY PRESS FIT, EXTERNAL EMI SPRINGS WITH HEATSINK PRODUCT SPEC: 108-2364 APPLICATION SPEC: 114-13120 SIZE: A1 CAGE CODE: 00779 DRAWING NO: C=2149730 RESTRICTED TO: -
0 PLC ±0.1		1 PLC ±0.1	
2 PLC ±0.1		3 PLC ±0.1	
4 PLC ±0.1		ANGLES ±1°	
MATERIAL:		FINISH:	WEIGHT: -
Customer Drawing		SCALE: 2:1	SHEET: 6 OF 9

LOC	DIST	REVISIONS					
GP	00	P	LTN	DESCRIPTION	DATE	DWN	APVD
		-		SEE SHEET 1			

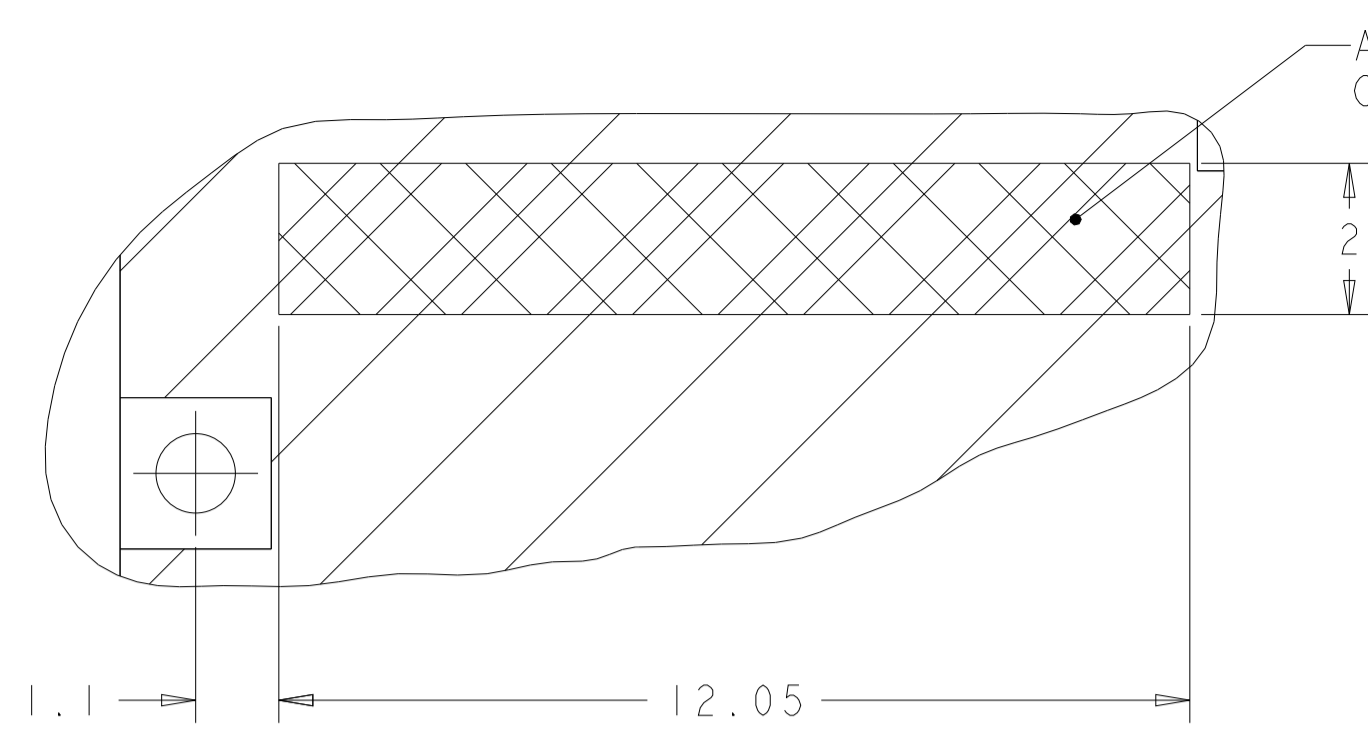

DETAIL B
4X INDIVIDUALLY
SCALE 10:1

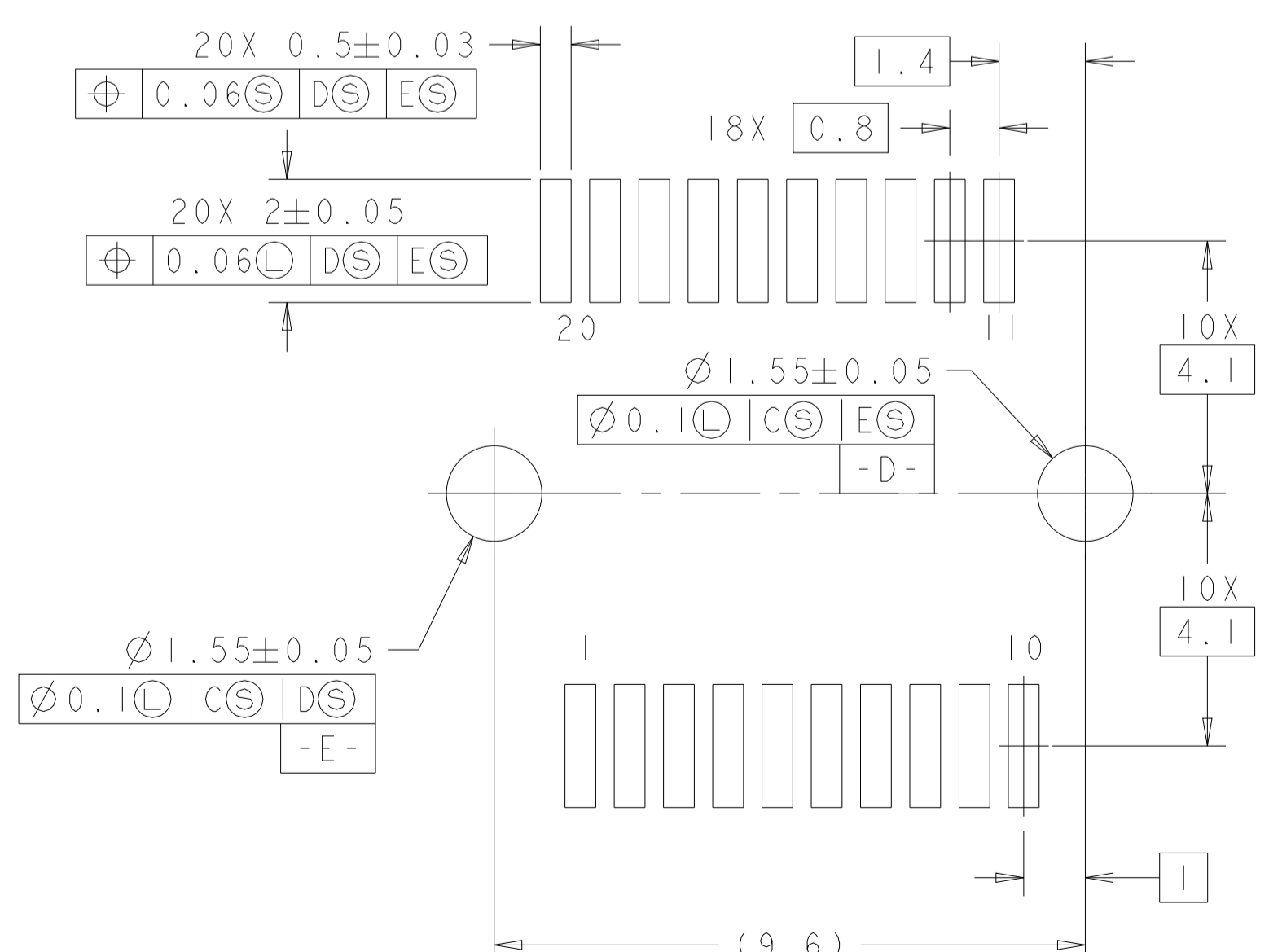
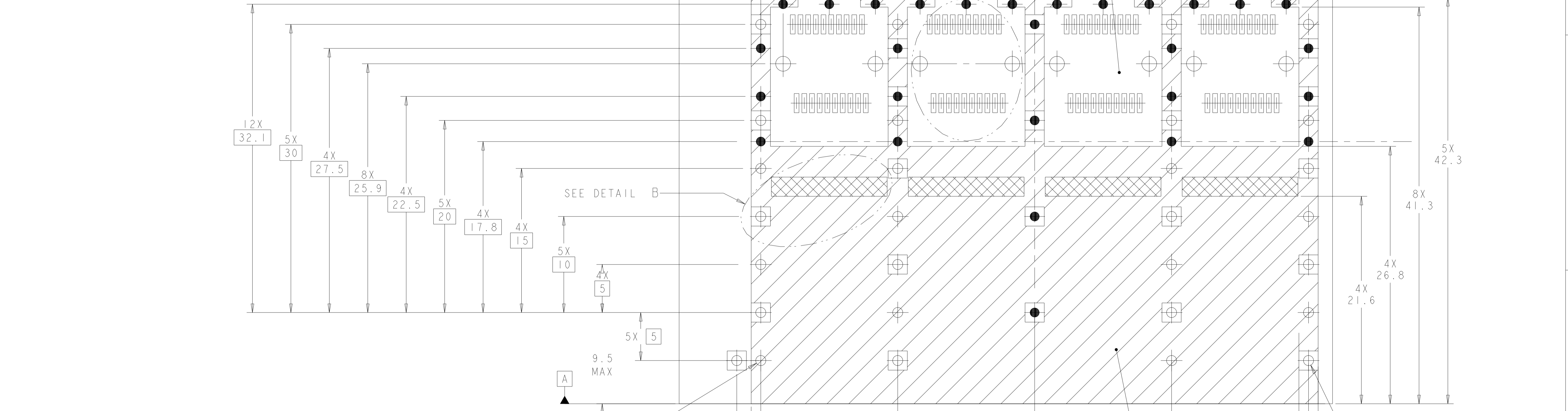

DETAIL G
RECOMMENDED PT CONNECTOR LAYOUT
8X INDIVIDUALLY
SCALE 10:1

DIMENSIONS:		TOLERANCES UNLESS OTHERWISE SPECIFIED:		MATERIAL		FINISH	
mm		0 PLC	±0.1				
		1 PLC	±0.1				
		2 PLC	±0.1				
		3 PLC	±0.1				
		4 PLC	±0.1				
		ANGLES	±1°				

THIS DRAWING IS A CONTROLLED DOCUMENT.		DWN: M. SCHMITT 23AUG2010		TE Connectivity	
		CHK: M. SCHMITT 23AUG2010		NAME: SFP+ ENHANCED 1X4 CAGE ASSEMBLY PRESS FIT, EXTERNAL EMI SPRINGS WITH HEATSINK	
		APVD: B. WERTZ 23AUG2010		PRODUCT SPEC: 108-2364	
				APPLICATION SPEC: 114-13120	
		WEIGHT: -		SIZE: A1	
		Customer Drawing		SCALE: 2:1 SHEET 7 OF 9 REV: A7	

LOC	DIST	REV	DATE	BY	APPV
GP	00				

REVISIONS		
NO.	DESCRIPTION	DATE
1	SEE SHEET 1	

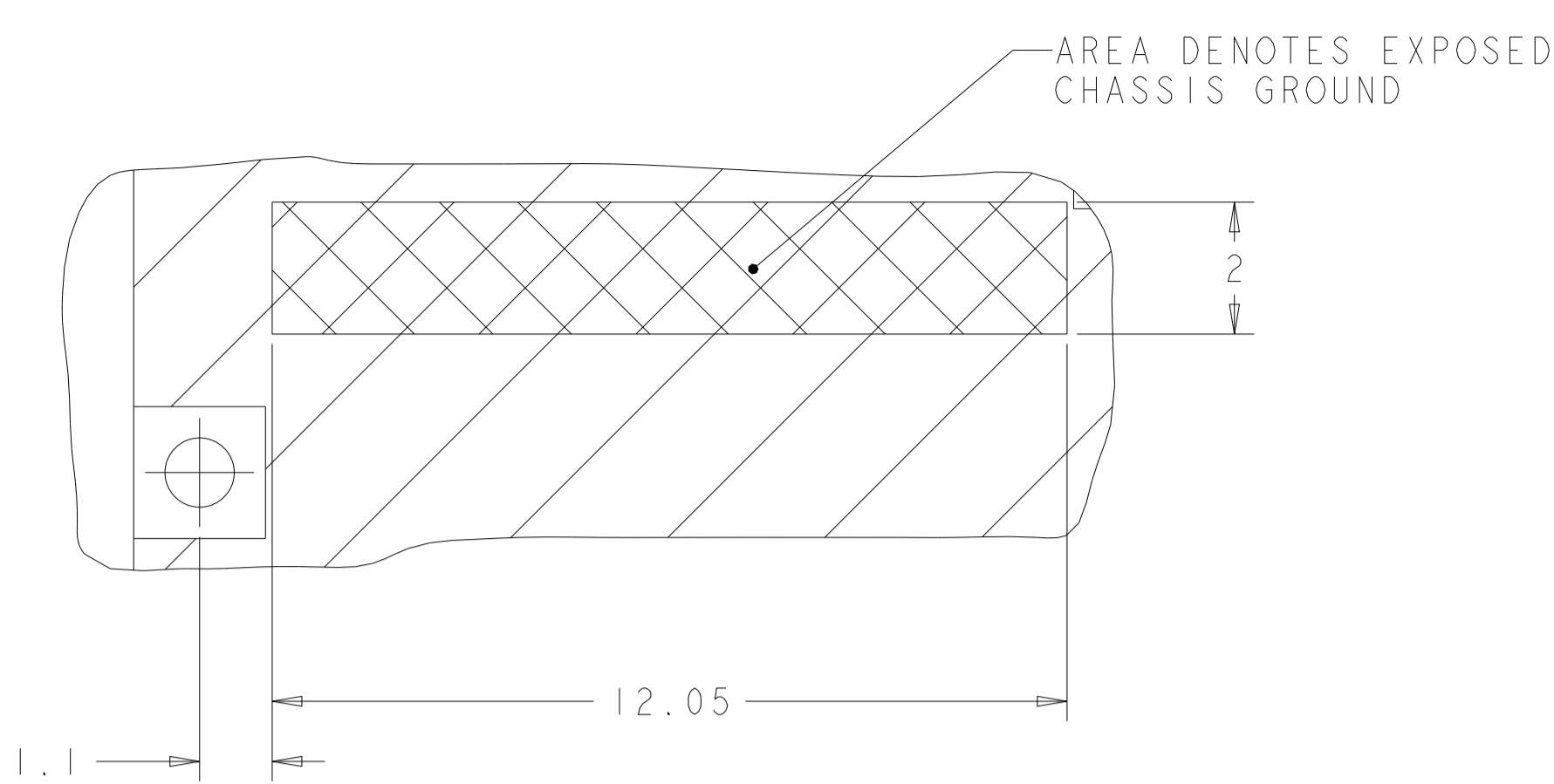

DETAIL A
4X INDIVIDUALLY
SCALE 10:1

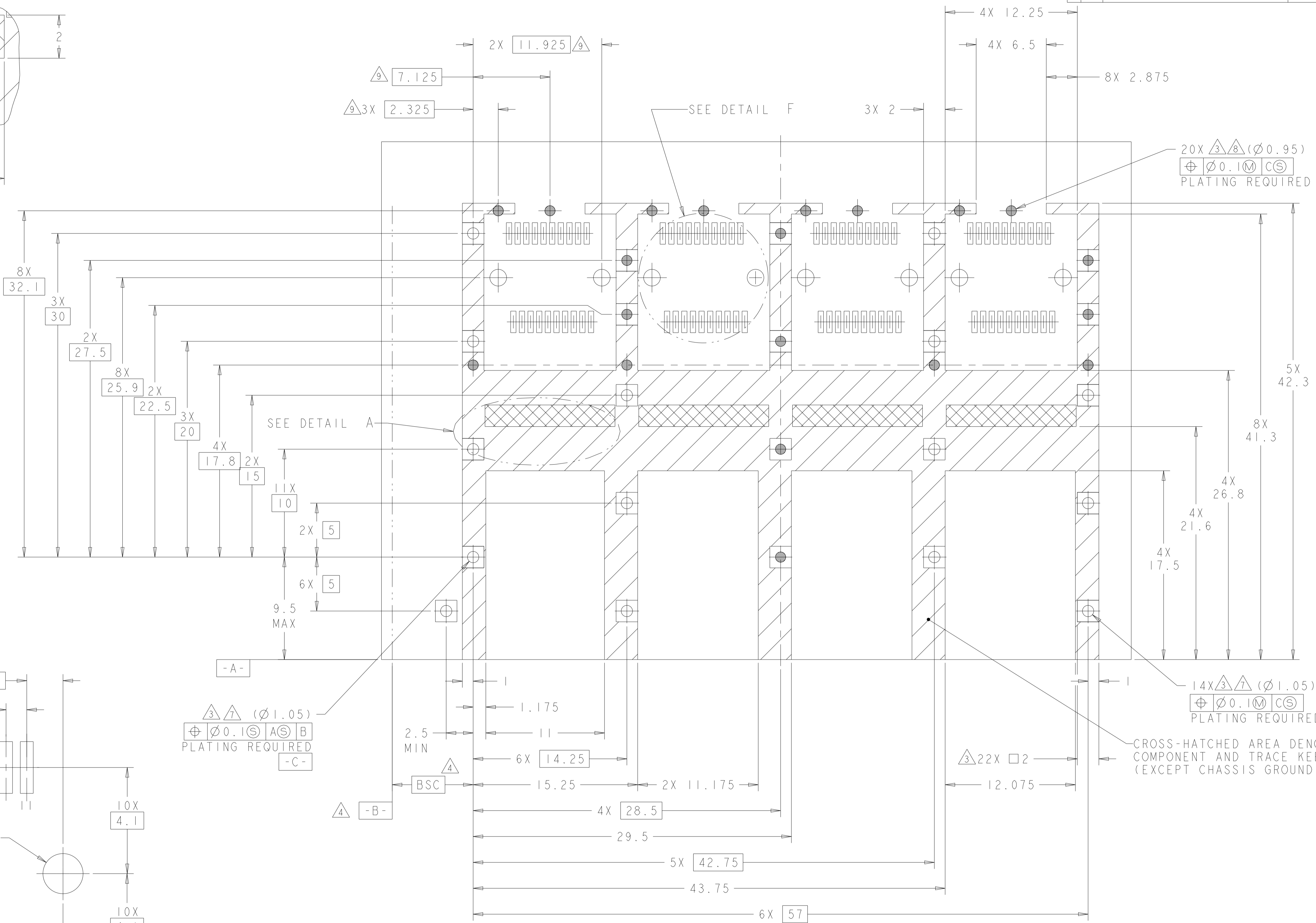

3/8 (Ø1.05)
Ø0.10 CS DS ES
PLATING REQUIRED
-C-

CROSS-HATCHED AREA DENOTES
COMPONENT AND TRACE KEEP-OUT
(EXCEPT CHASSIS GROUND)

RECOMMENDED PCB CONFIGURATION
WITH KEEP-OUT AREAS
SINGLE SIDED APPLICATIONS
WITH INSULATING TAPE

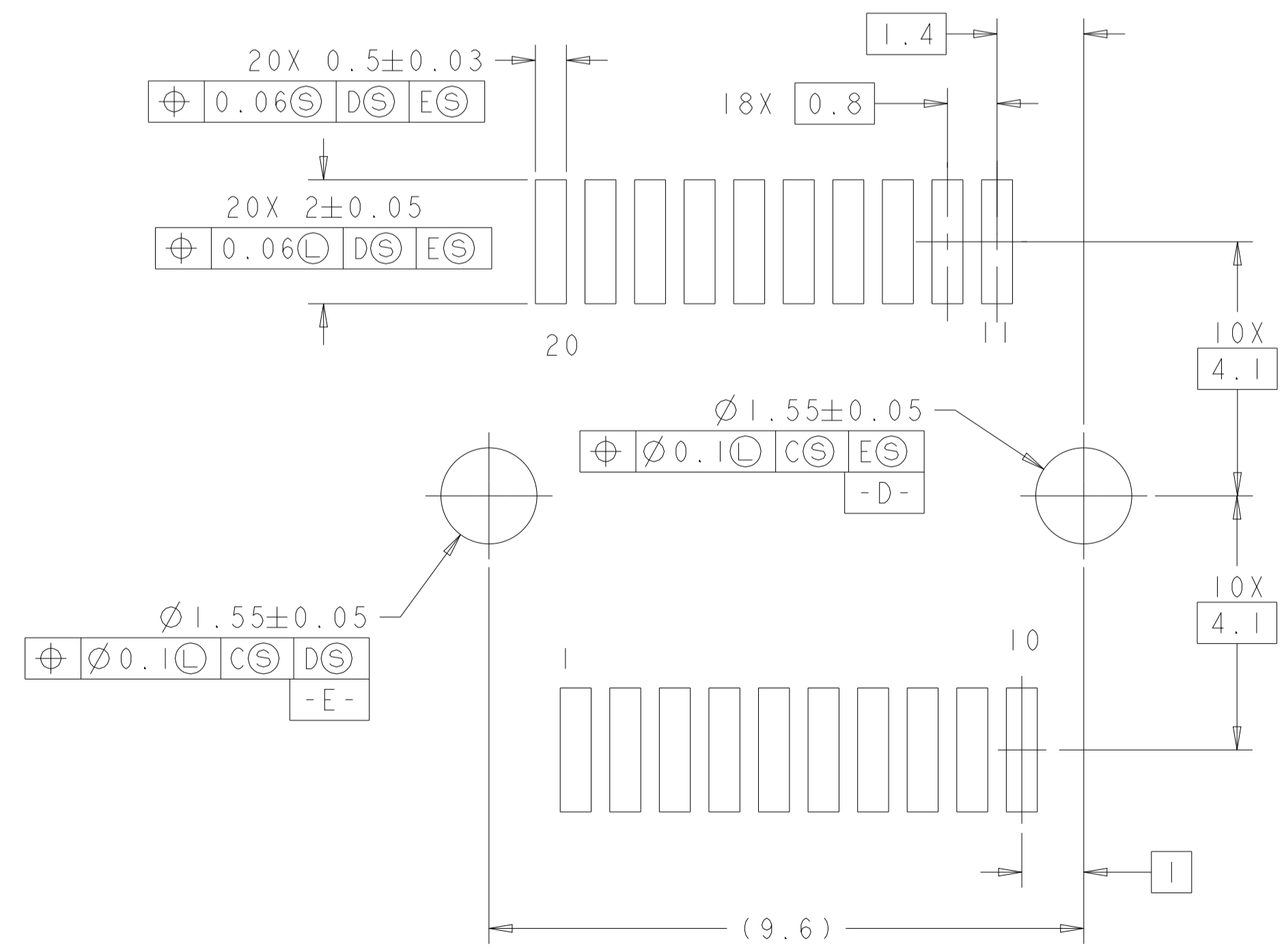

DETAIL F
RECOMMENDED PT CONNECTOR LAYOUT
SCALE 12:1

THIS DRAWING IS A CONTROLLED DOCUMENT.		OWN: M. SCHMITT 23AUG2010	TE Connectivity
DIMENSIONS: mm		CHK: M. SCHMITT 23AUG2010	
TOLERANCES UNLESS OTHERWISE SPECIFIED:		APV: B. WERTZ 23AUG2010	NAME: SFP+ ENHANCED 1X4 CAGE ASSEMBLY PRESS FIT, EXTERNAL EMI SPRINGS WITH HEATSINK
0 PLC ±0.1		PRODUCT SPEC: 108-2364	
1 PLC ±0.1		APPLICATION SPEC: 114-13120	SIZE: A1 CAGE CODE: 00779 DRAWING NO: 2149730
2 PLC ±0.1		WEIGHT: -	
3 PLC ±0.1		Customer Drawing	RESTRICTED TO: -
4 PLC ±0.1		SCALE: 2:1	SHEET: 8 OF 9
ANGLES ±1°		REV: A7	
FINISH			

LOC	DIST	REV	DATE	BY	APPV
GP	00				

REVISIONS			
NO.	DESCRIPTION	DATE	BY
1	SEE SHEET 1		

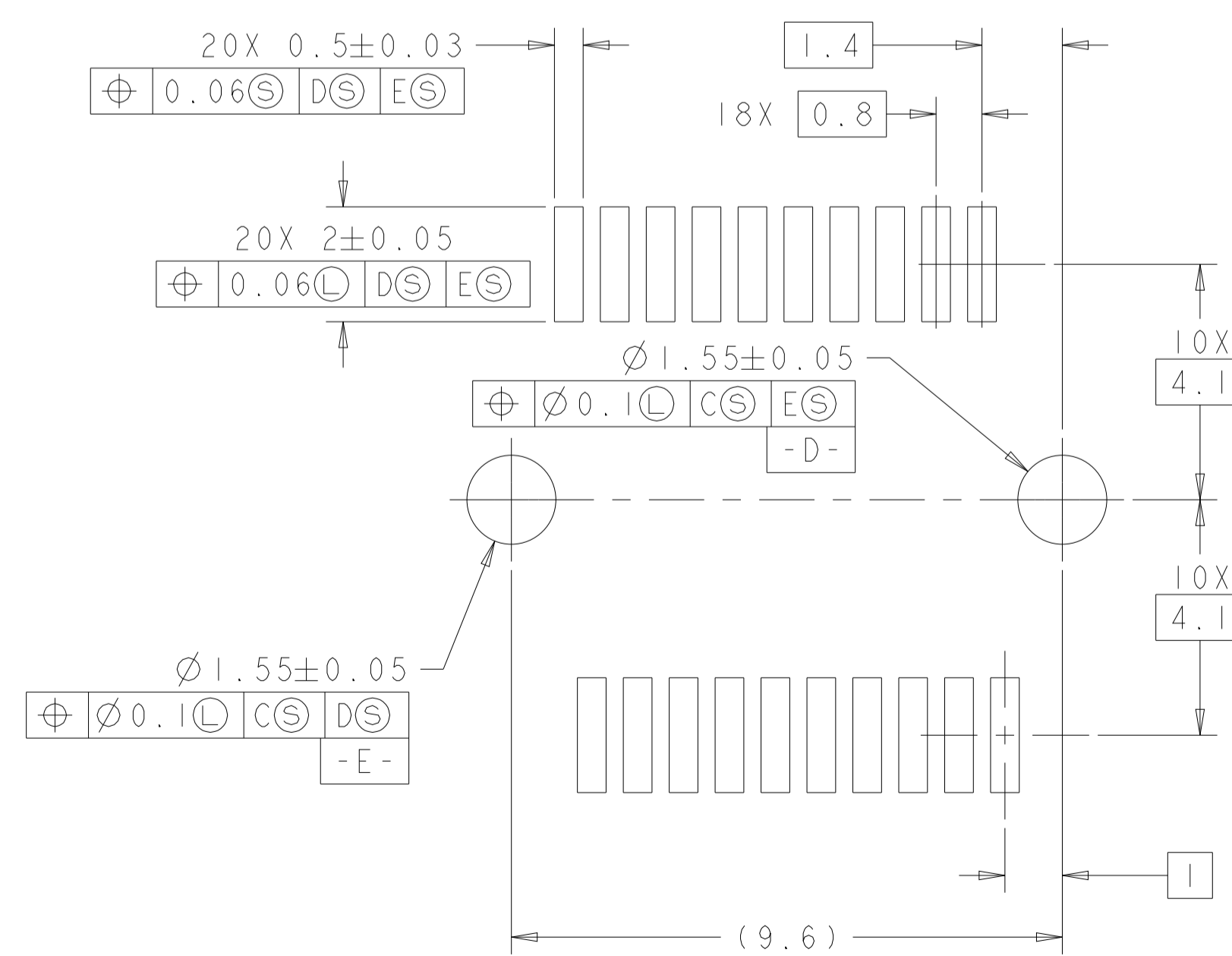
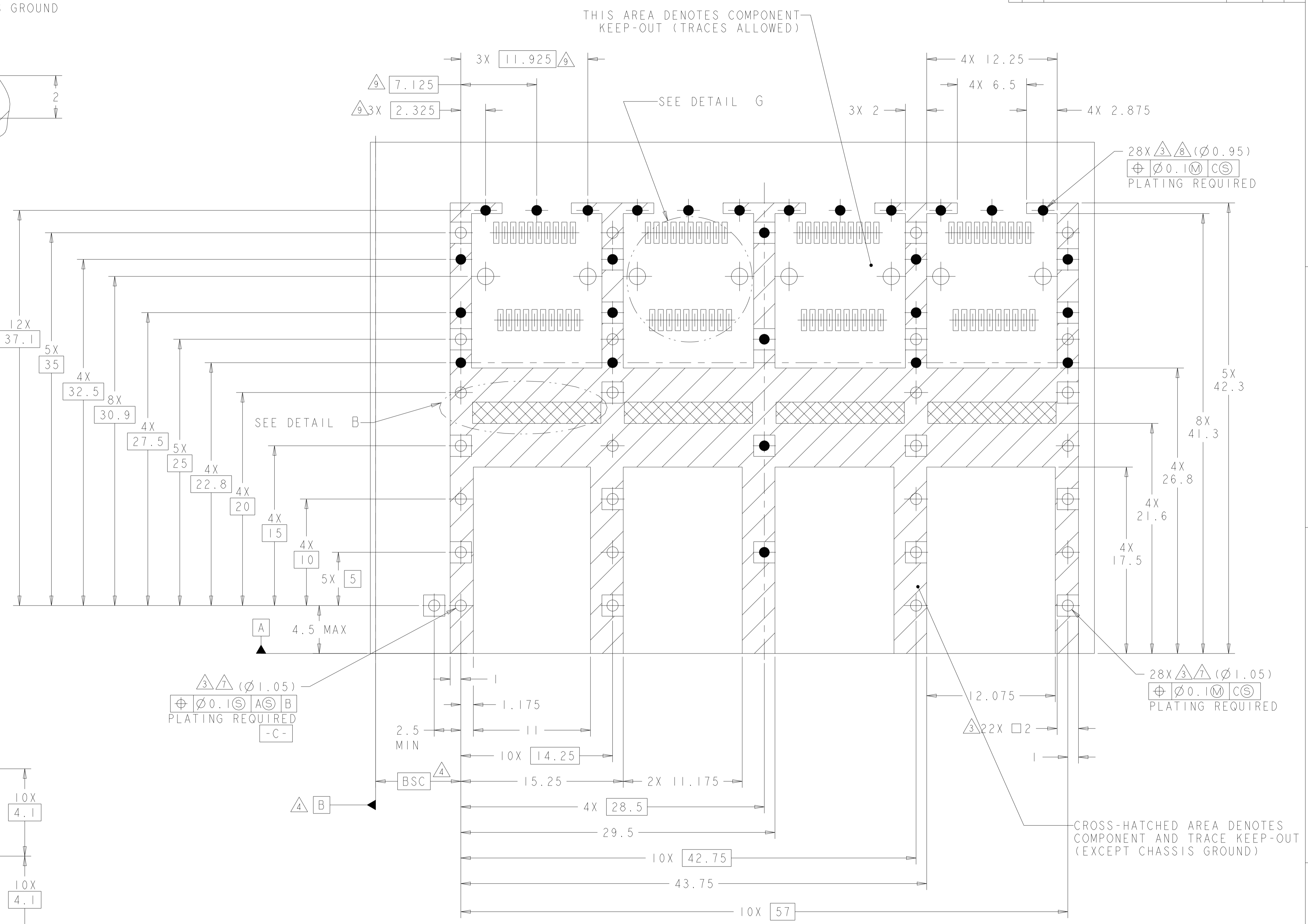
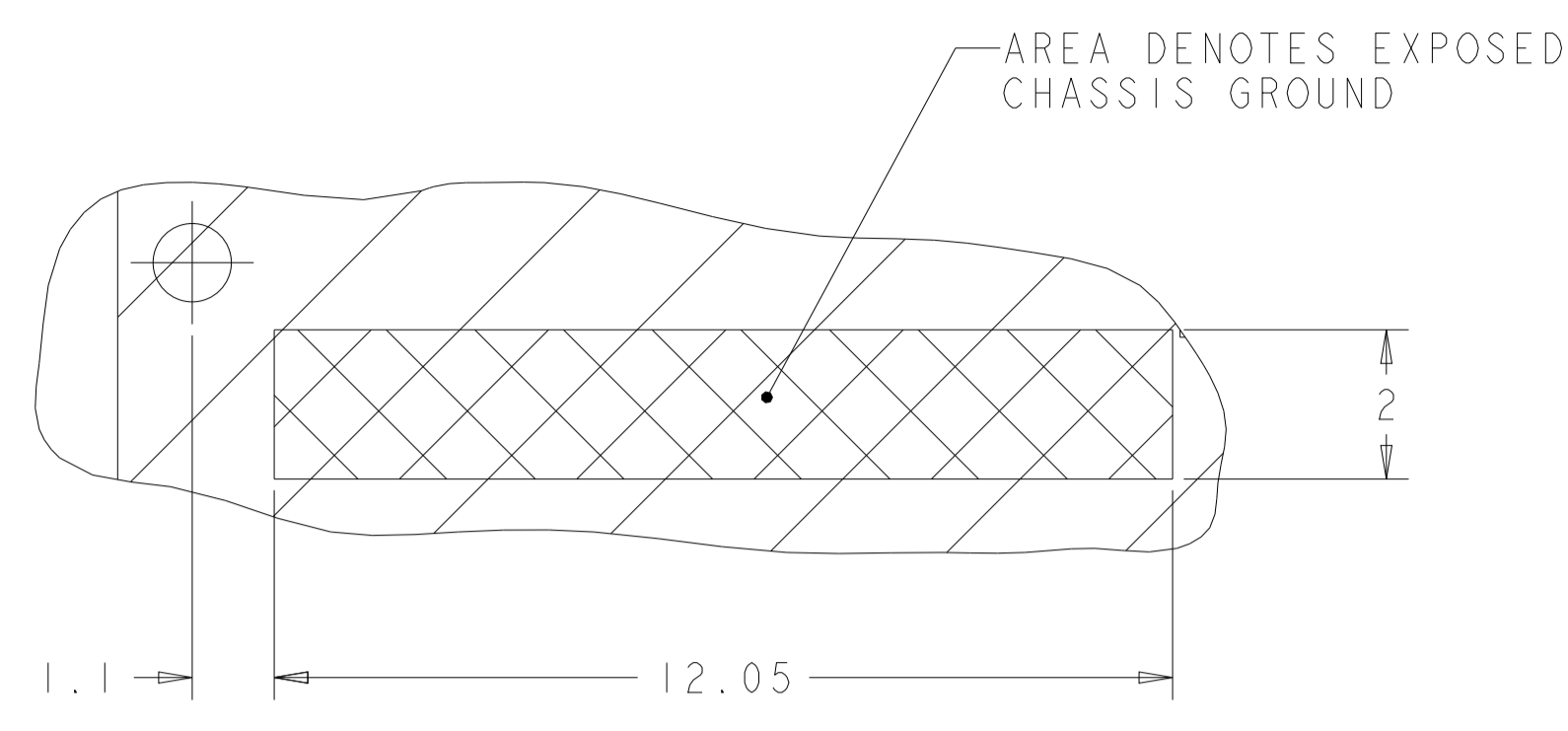

RECOMMENDED PCB CONFIGURATION WITH KEEP-OUT AREAS BELLY TO BELLY APPLICATIONS WITH INSULATING TAPE

DETAIL G
RECOMMENDED PCB CONFIGURATION WITH KEEP-OUT AREAS BELLY TO BELLY APPLICATIONS WITH INSULATING TAPE
SCALE 10:1

THIS DRAWING IS A CONTROLLED DOCUMENT.		OWN: M. SCHMITT 23AUG2010	TE Connectivity
DIMENSIONS: mm		CHK: M. SCHMITT 23AUG2010	
TOLERANCES UNLESS OTHERWISE SPECIFIED:		APV: B. WERTZ 23AUG2010	NAME: SFP+ ENHANCED 1X4 CAGE ASSEMBLY PRESS FIT, EXTERNAL EMI SPRINGS WITH HEATSINK
0 PLC ±0.1		PRODUCT SPEC: 108-2364	SIZE: 114-13120
1 PLC ±0.1		APPLICATION SPEC: 114-13120	RESTRICTED TO: -
2 PLC ±0.1		WEIGHT: -	SCALE: 2:1
3 PLC ±0.1		Customer Drawing	SHEET 9 of 9
4 PLC ±0.1			REV: A7
ANGLES ±1°			
FINISH			

单击下面可查看定价，库存，交付和生命周期等信息

[>>TE Connectivity\(泰科\)](#)