

THIS DRAWING IS UNPUBLISHED. RELEASED FOR PUBLICATION 20
 © COPYRIGHT 20 BY TYCO ELECTRONICS CORPORATION. ALL RIGHTS RESERVED.

LOC	DIST	REVISIONS					
		P	LTR	DESCRIPTION	DATE	DWN	APVD
CE	16		1	PPR 04-299	14APR04	KG	DW
			A	RELEASE PER 0A00-0332-04	07JUL04	KG	DW
			B	REVISE PER 0A00-0019-05	01MAR2005	KG	DW

- ASSEMBLY SHOWN FOR REFERENCE ONLY. SHIPPED LOOSE PIECE AS SHOWN ON PAGE 2.
- ALL ASSEMBLY DIMENSIONS ARE FOR REFERENCE ONLY.
- △ PANEL THICKNESS: 6mm MAXIMUM.
- △ CONNECTOR CAN BE INSTALLED AS FRONT-PANEL-MOUNT OR REAR-PANEL-MOUNT. INSTALL 30x2 O-RING IN APPROPRIATE SIDE OF FLANGE.
- THIS PRODUCT HAS NOT COMPLETED VALIDATION TESTING.
- COMPLETE THE CONNECTOR ASSEMBLY BY ADDING EACH OF THE FOLLOWING PRO BEAM JR KITS:
 - EXPANDED BEAM INSERT ASSEMBLY KIT
 - FERRULE KIT, ONE PER FIBER

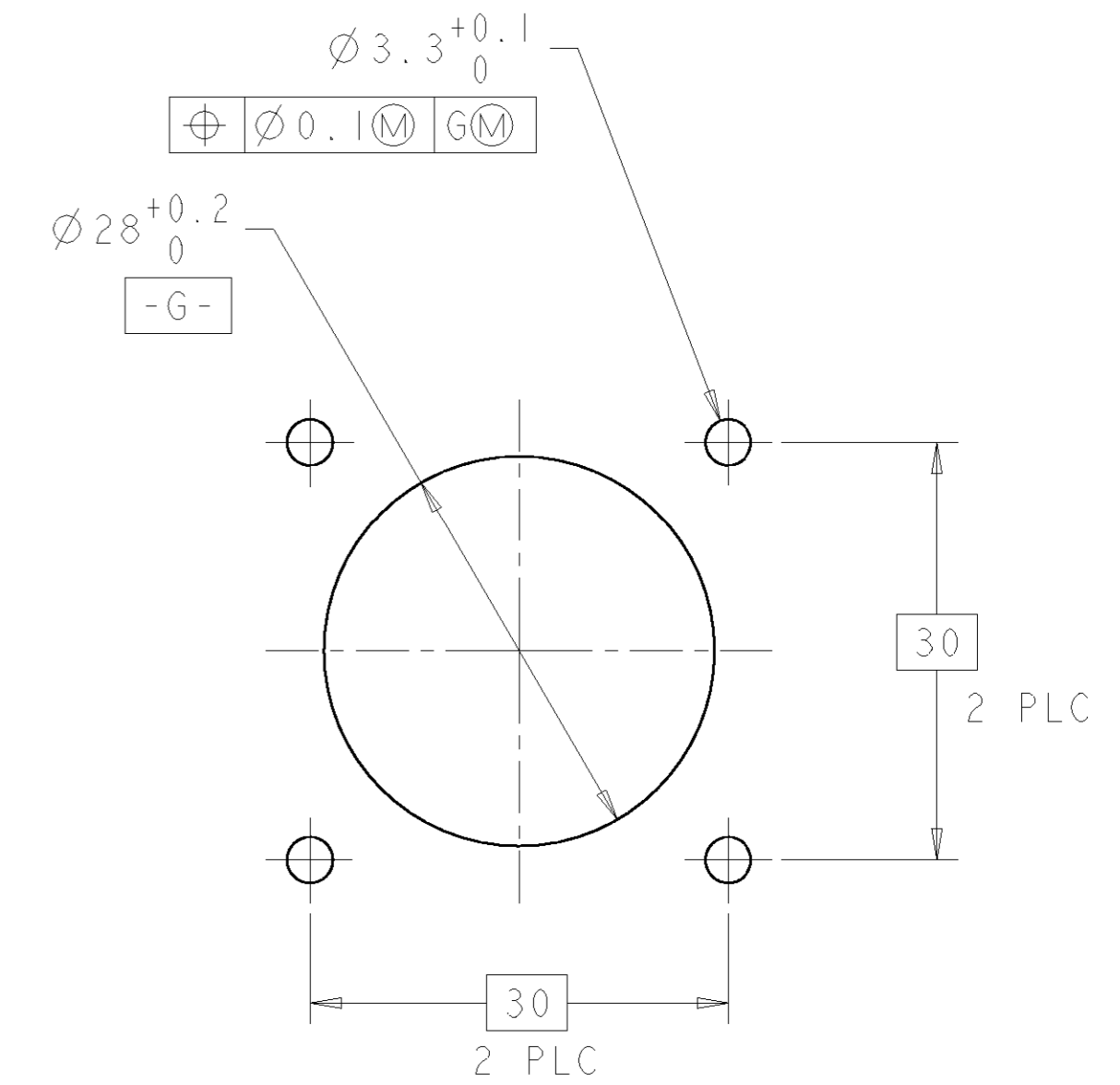
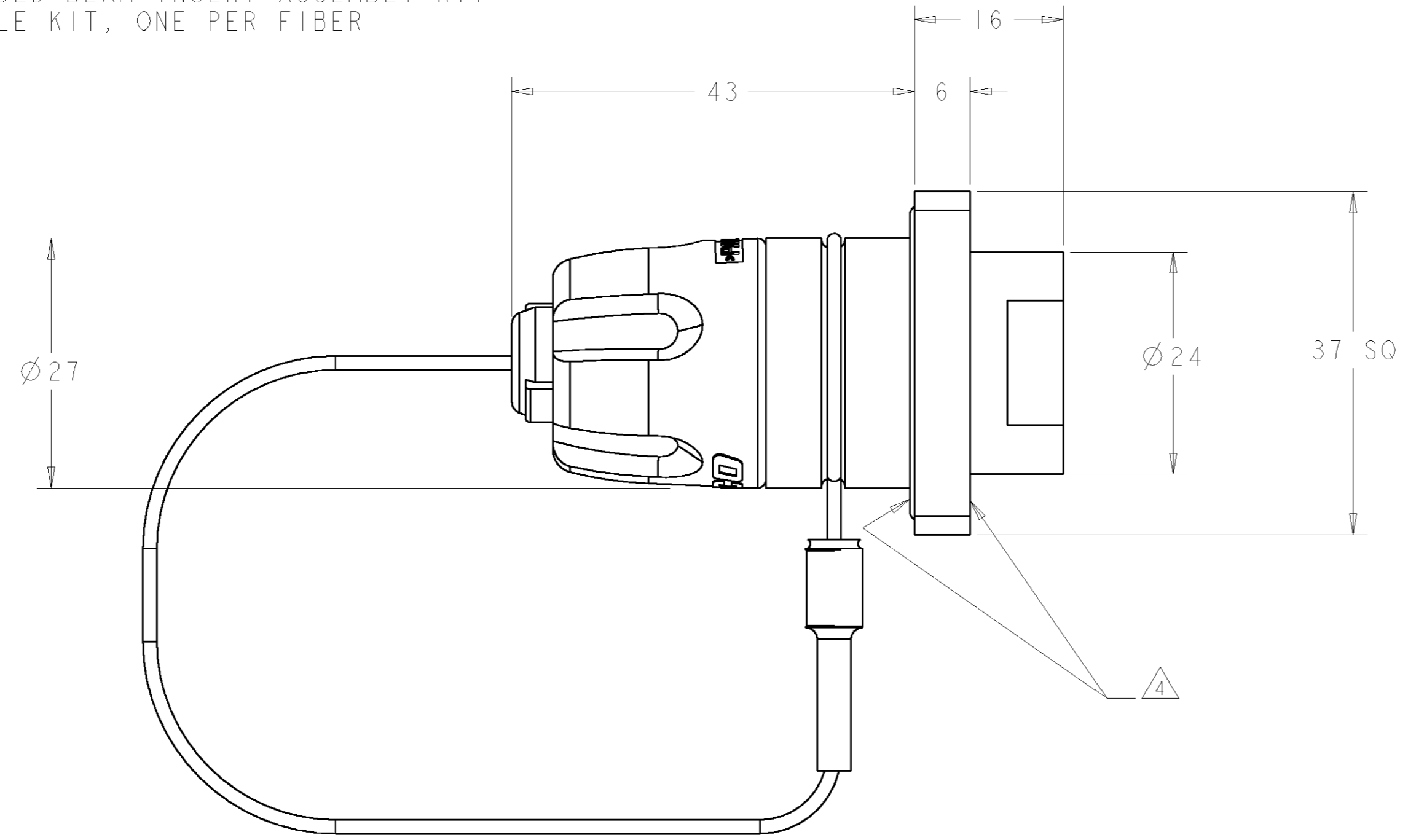

△△ RECOMMENDED PANEL CUT-OUT

NICKEL ALUMINUM BRONZE	1754439-2
ALUMINUM	1754439-1
HOUSING ALLOY	PART NUMBER

THIS DRAWING IS A CONTROLLED DOCUMENT FOR TYCO ELECTRONICS CORPORATION. IT IS SUBJECT TO CHANGE AND THE CONTROLLING ENGINEERING ORGANIZATION SHOULD BE CONTACTED FOR THE LATEST REVISION.		DWN K. GLATFELTER 24MAR2004	Tyco Electronics Harrisburg, PA 17105-3608	
DIMENSIONS: mm		CHK D. WERTMAN 13APR2004	NAME CONNECTOR SHELL KIT, SQ-FLANGE LP BULKHEAD, PRO BEAM JR.	
TOLERANCES UNLESS OTHERWISE SPECIFIED: 0 PLC ± 1 PLC ± 2 PLC ± 3 PLC ± 4 PLC ± ANGLES ±		APVD D. WERTMAN 14APR2004	RESTRICTED TO	
MATERIAL - HARD ANODIZE (AL ONLY)		PRODUCT SPEC - APPLICATION SPEC - WEIGHT -	SIZE A2	CAGE CODE 00779
		DRAWING NO 1754439		REV B
		CUSTOMER DRAWING		SCALE 2:1 SHEET 1 OF 2

THIS DRAWING IS UNPUBLISHED. RELEASED FOR PUBLICATION 20
 © COPYRIGHT 20 BY TYCO ELECTRONICS CORPORATION. ALL RIGHTS RESERVED.

LOC	DIST	REVISIONS					
		P	LTR	DESCRIPTION	DATE	DWN	APVD
CE	16	-		SEE SHEET 1	-	-	-

1. SHIPPED LOOSE PIECE AS SHOWN.

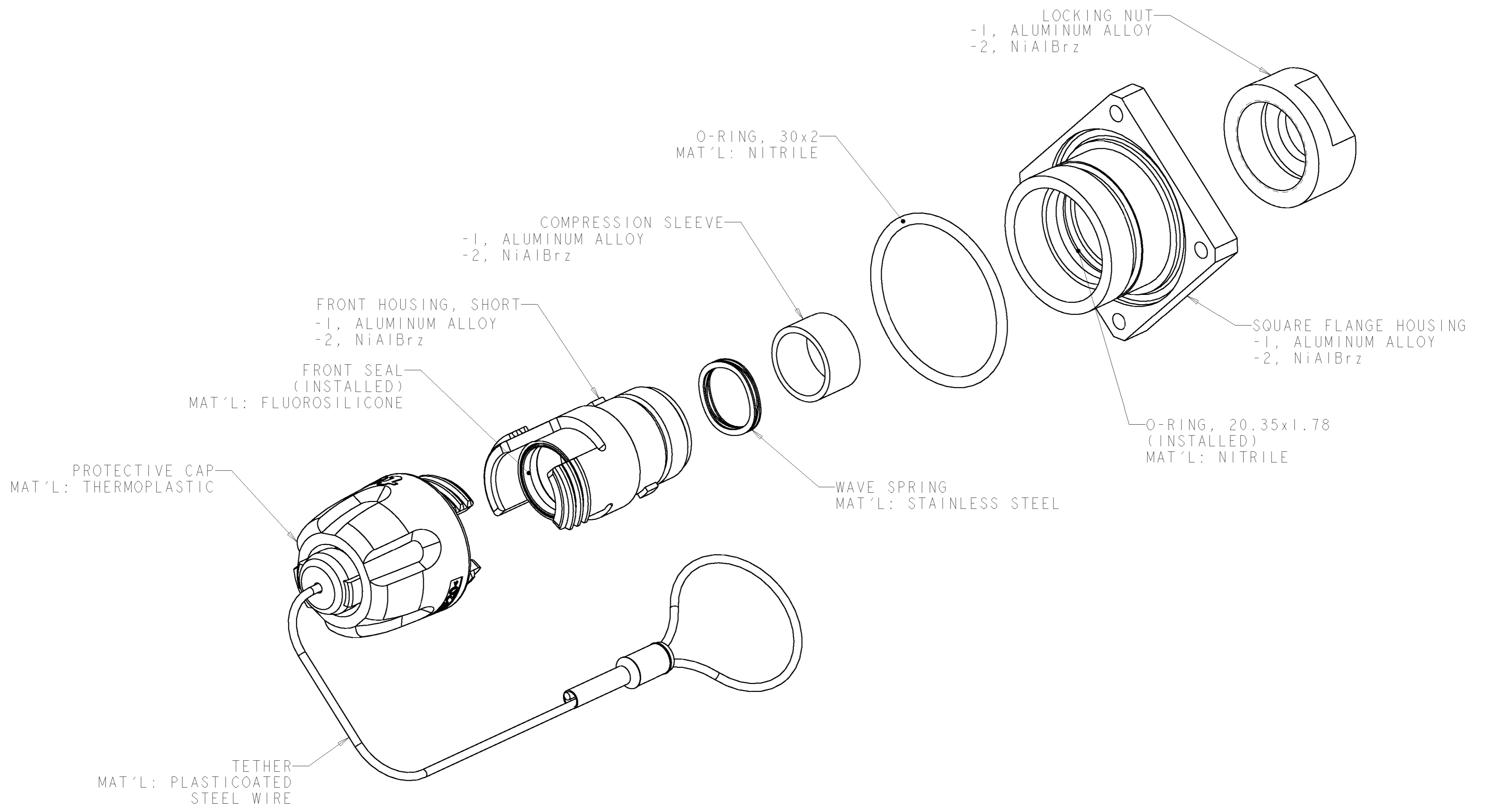

<small>THIS DRAWING IS A CONTROLLED DOCUMENT FOR TYCO ELECTRONICS CORPORATION. IT IS SUBJECT TO CHANGE AND THE CONTROLLING ENGINEERING ORGANIZATION SHOULD BE CONTACTED FOR THE LATEST REVISION.</small>		DWN K. GLATFELTER 24MAR2004 CHK D. WERTMAN 13APR2004 APVD D. WERTMAN 14APR2004	tyco Electronics Tyco Electronics Harrisburg, PA 17105-3608
DIMENSIONS: mm 	TOLERANCES UNLESS OTHERWISE SPECIFIED: 0 PLC ± 1 PLC ± 2 PLC ± 3 PLC ± 4 PLC ± ANGLES ± FINISH HARD ANODIZE (A1 ONLY)	PRODUCT SPEC - APPLICATION SPEC - WEIGHT - CUSTOMER DRAWING	NAME CONNECTOR SHELL KIT, SQ-FLANGE LP BULKHEAD, PRO BEAM JR. SIZE A2 CAGE CODE 00779 DRAWING NO. 1754439 RESTRICTED TO - SCALE 2:1 SHEET 2 OF 2 REV B

单击下面可查看定价，库存，交付和生命周期等信息

[>>TE Connectivity\(泰科\)](#)