

LOC	DIST	REVISIONS			
P	LF#	DESCRIPTION	DATE	OWN	APVD
P		REVISED AND REDRAWN FOR ECR-07-014697	02JUL2007	M.P.	R.M
P1		REVISED PER ECO-19-008278	30MAY19	AP	WN

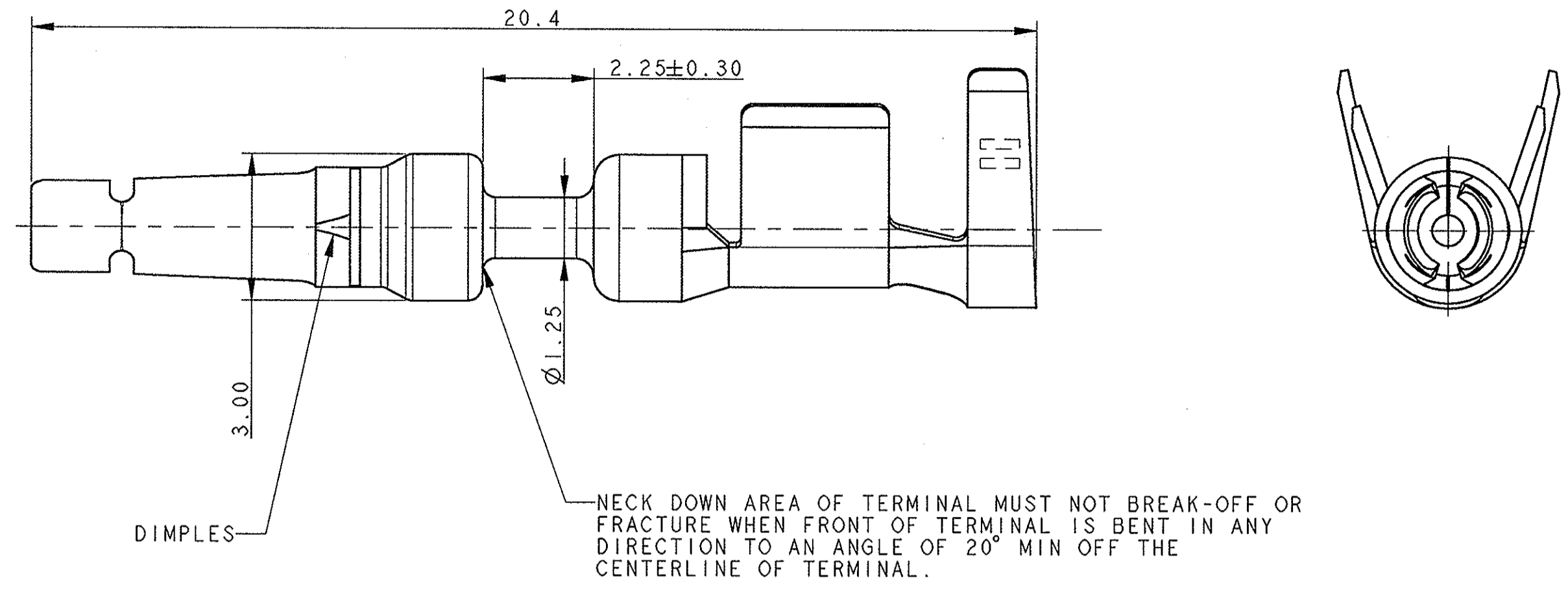

VIEW WITHOUT SLEEVE

CRIMP TYPE	B _c	D _c	H _c	B _i	D _i	H _i	CRIMP CODE
c	3.70 ±0.15	1.80 ±0.2	3.90 ±0.15	4.70 ±0.15	2.60 ±0.2	4.90 ±0.15	☐☐☐☐
b	2.60 ±0.15	1.20 ±0.2	2.90 ±0.15	3.60 ±0.15	2.00 ±0.2	4.00 ±0.15	☐☐☐☐
a	2.00 ±0.15	0.80 ±0.2	2.20 ±0.15	2.80 ±0.15	1.60 ±0.2	3.00 ±0.15	☐☐☐☐

FULL SIZE VIEWS
SCALE 1.000

FULL ASSY VIEW
WATERPROOF
SCALE 2.000

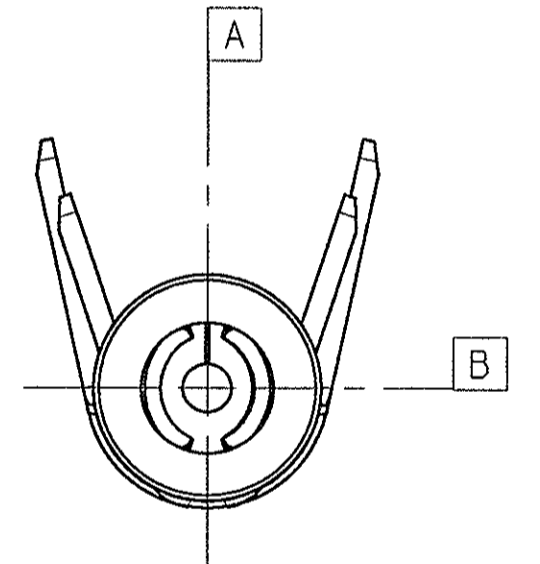
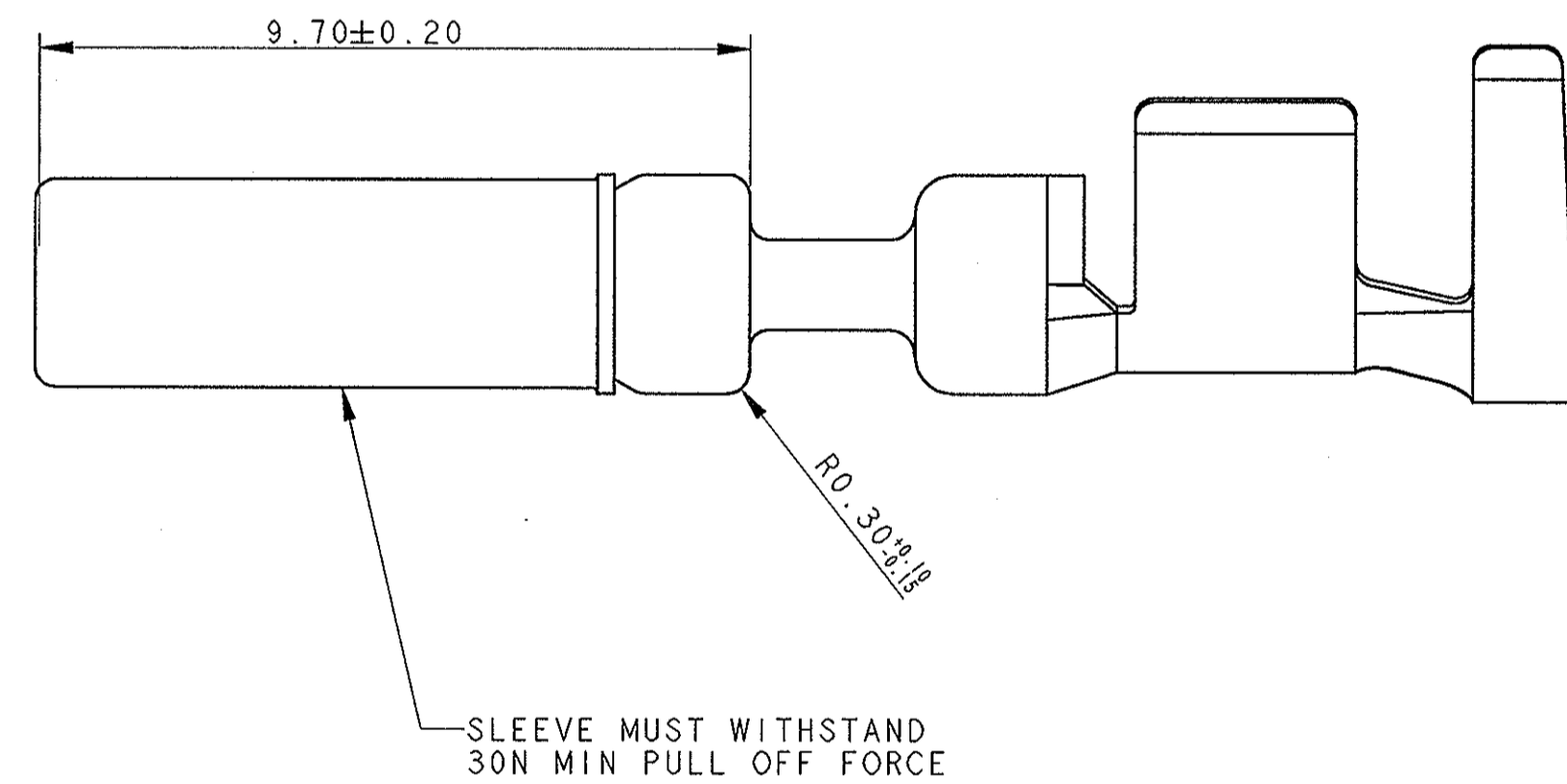
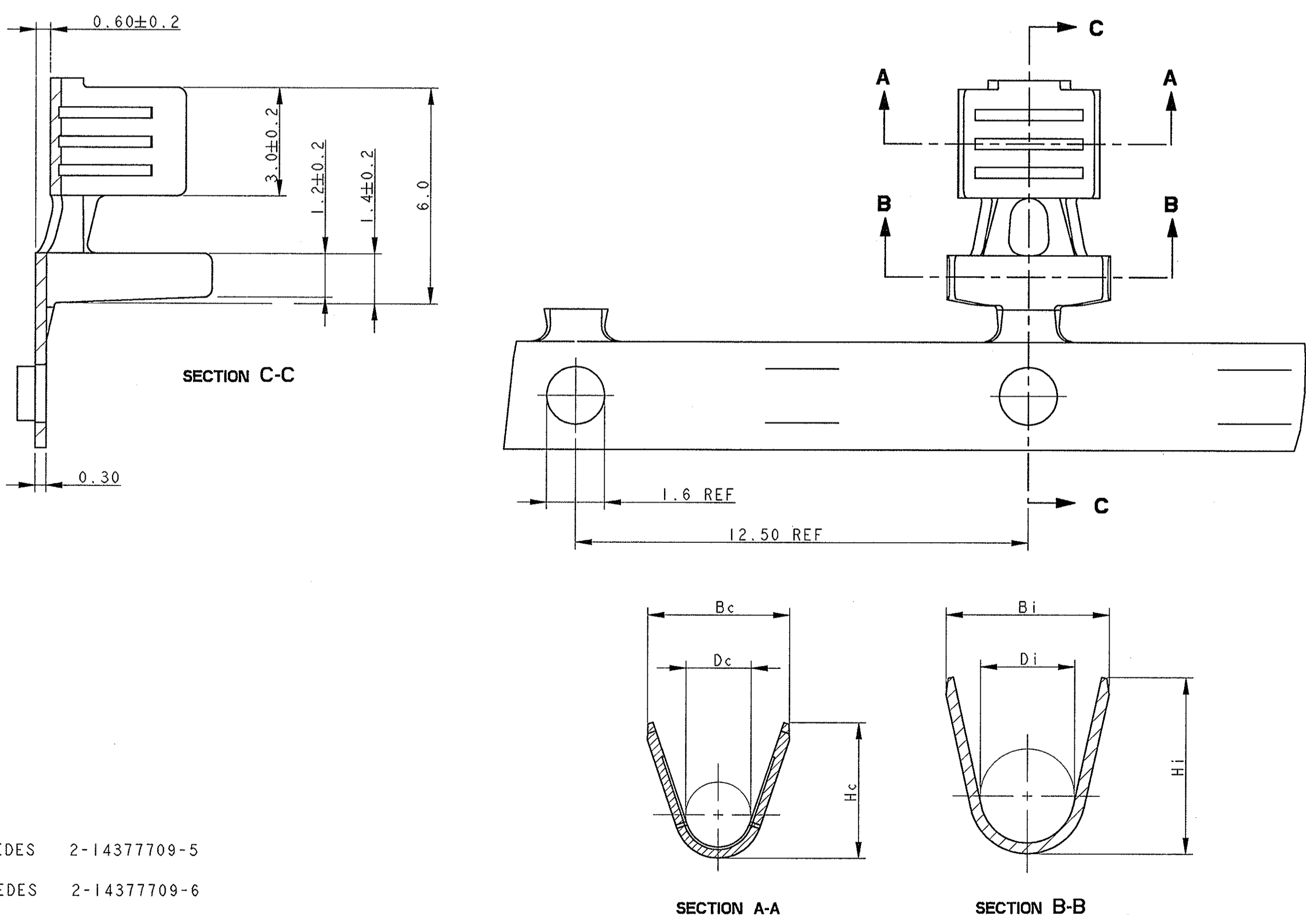
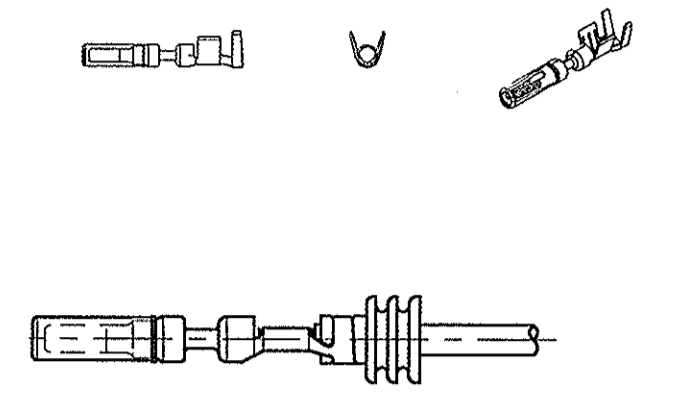

- 1 SUPERSEDES 2-1437709-5
- 2 SUPERSEDES 2-1437709-6
- 3 SUPERSEDES 2-1437709-7

PART AS SUPPLIED							COMPONENTS			MATERIALS			COMPONENTS SUPPLIED APART		TO FIT IN CAVITY	
P/N	PART REV.	DESCRIPTION	WATERPROOF	WIRE CROSS SEC. AREA	CRIMP CODE	CRIMP SPEC.	WEIGHT	TERMINAL	SLEEVE	WIRE SEAL	TERMINAL	SLEEVE	GREASE	WIRE SEAL	TYPE	DESCRIPTION
1-1437709-4		TERMINAL FEMALE TIN PLT.	YES	0.22-0.35mm ²	☐☐☐☐		0.402gr.	I	I	SEE CHART	DIN 17670 (CuSn6) TIN PLATED BRIGHT	ALLOY 230 RICH LOW BRASS	LITHIUM SOAP ZINC OXIDE	1-1437713-1 (0.22-0.35) BLACK	AC/T/19/95	CAVITY TERMINAL FEMALE
1-1437709-5	B	TERMINAL FEMALE TIN PLT.		0.50-1.00mm ²	☐☐☐☐		0.422gr.	I	I					1-1437713-2 (0.50-1.00) RED		
1-1437709-6		TERMINAL FEMALE TIN PLT.		1.50-2.50mm ²	☐☐☐☐		0.443gr.	I	I					1-1437713-3 (1.50) BLUE		
1-1437709-4	B	TERMINAL FEMALE TIN PLT.	NO	0.22-0.35mm ²	☐☐☐☐	AC/T/18/95	0.402gr.	I	I	NOT USED						
2-1437709-8	P	TERMINAL FEMALE TIN PLT.		0.50-1.00mm ²	☐☐☐☐		0.422gr.	I	I							
1-1437709-5	B	TERMINAL FEMALE TIN PLT.		0.50-1.00mm ²	☐☐☐☐		0.422gr.	I	I							
1-1437709-6	B	TERMINAL FEMALE TIN PLT.		1.50-2.50mm ²	☐☐☐☐		0.443gr.	I	I							

THIS DRAWING IS A CONTROLLED DOCUMENT FOR THE COMPANY'S ORGANIZATION. IT IS SUBJECT TO CHANGE AND THE COMPANY'S ORGANIZATION SHOULD BE CONTACTED FOR THE LATEST VERSION.

DATE: 20 JUN 2007
 DWN: M. PALMA
 CHK: R. MARTINI
 APVD: A. GENTA

TE Connectivity
STE
 1,6 SYSTEM TERMINAL FEMALE TIN PLATED

PRODUCT SPEC: 108-20260
 APPLICATION SPEC: 114-20121

SIZE: A11
 CAGE CODE: 00779
 DRAWING NO: C-1418069

CUSTOMER DRAWING
 SCALE: 10:1
 SHEET: 1 OF 2
 REV: P1

LOC	DIST	REV	DESCRIPTION	DATE	DRN	APVD
A1	-	-	-SEE SHEET 1-	-	-	-

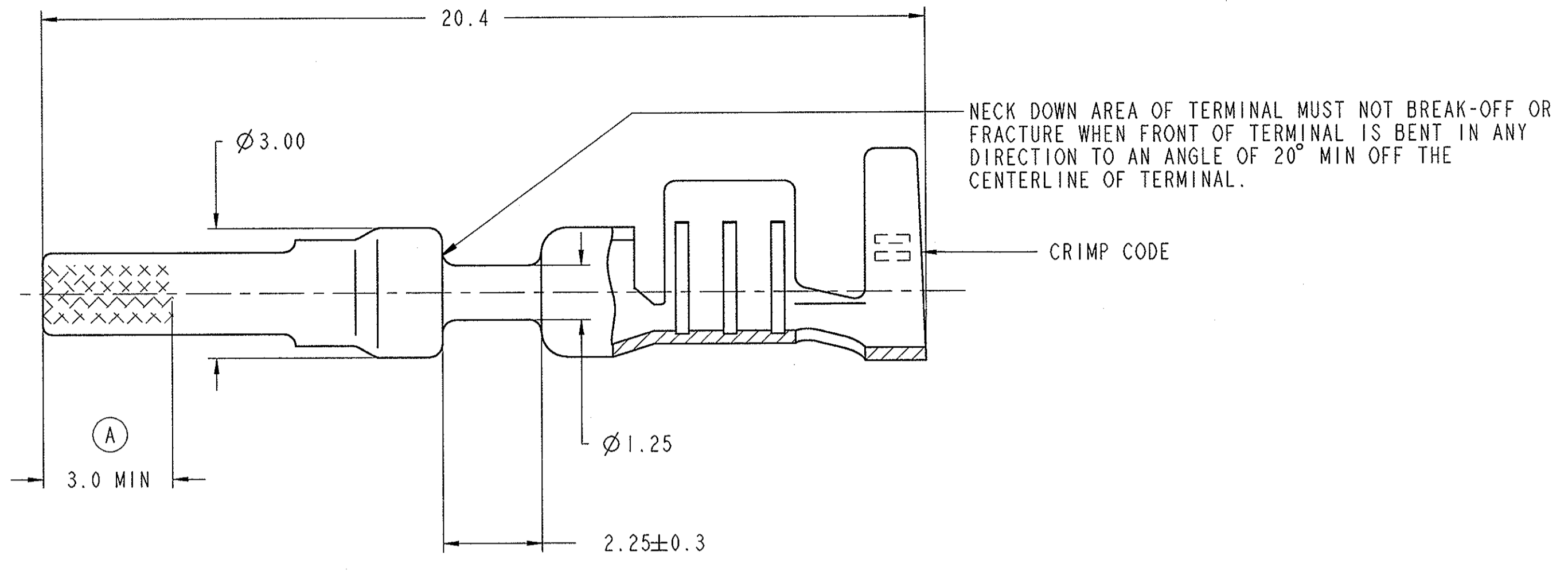

CRIMP TYPE	CRIMP AREA DIMENSION						CRIMP CODE	
	Bc	Dc	Hc	Bi	Di	Hi		
I	c	3.70 ±0.15	1.80 ±0.2	3.90 ±0.15	4.70 ±0.15	2.60 ±0.2	4.90 ±0.15	
	b	2.60 ±0.15	1.20 ±0.2	2.90 ±0.15	3.60 ±0.15	2.00 ±0.2	4.00 ±0.15	
	a	2.00 ±0.15	0.80 ±0.2	2.20 ±0.15	2.80 ±0.15	1.60 ±0.2	3.00 ±0.15	

FULL SIZE VIEWS
SCALE 1.000

FULL ASSY VIEW WATERPROOF
SCALE 2.000

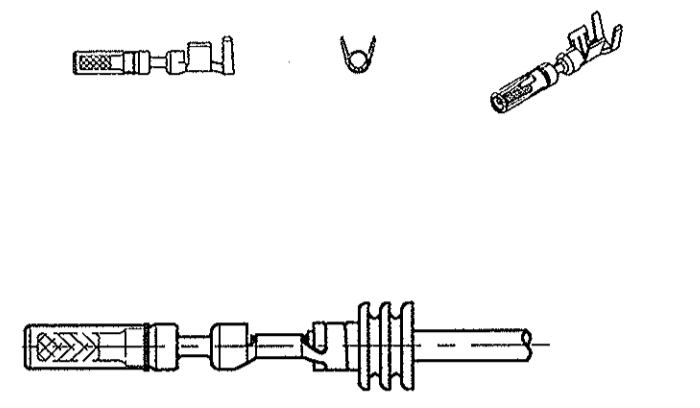

SECTION C-C

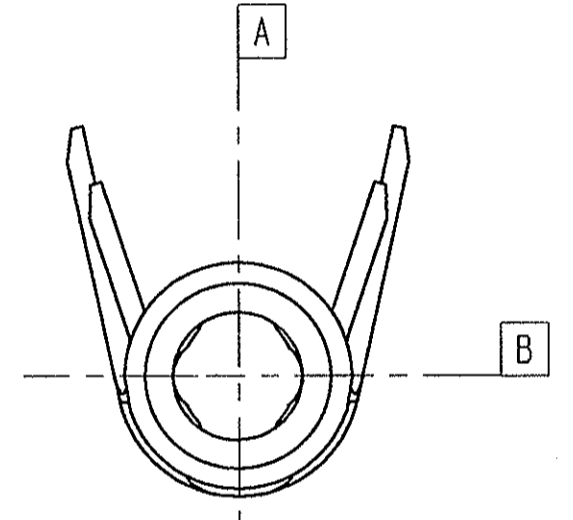
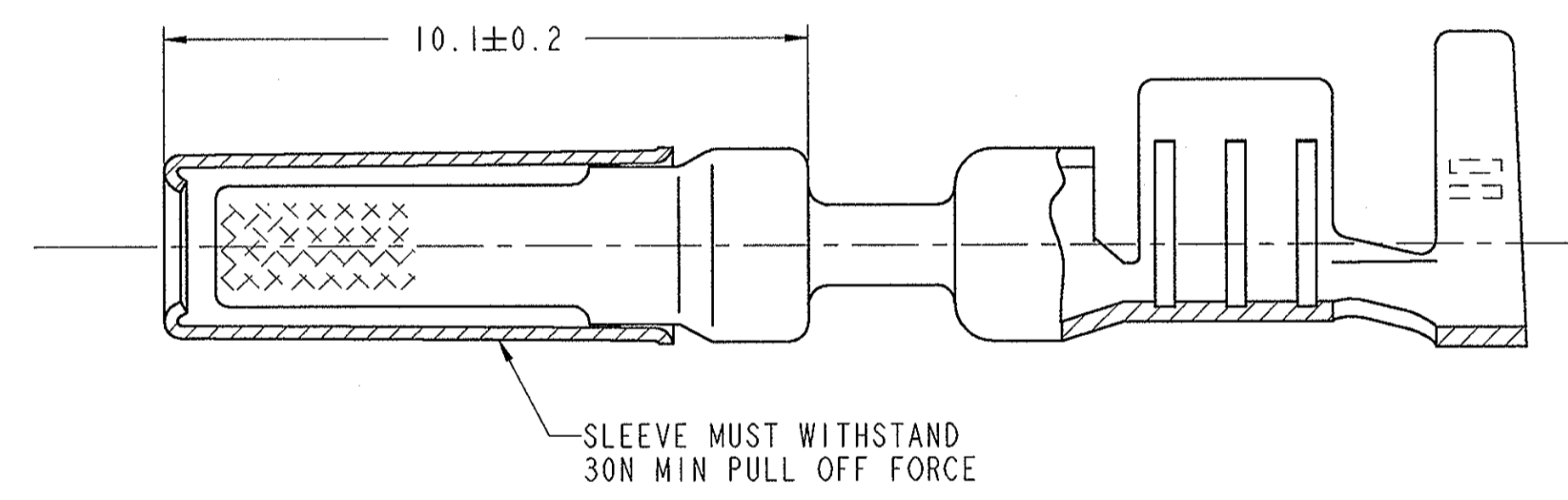
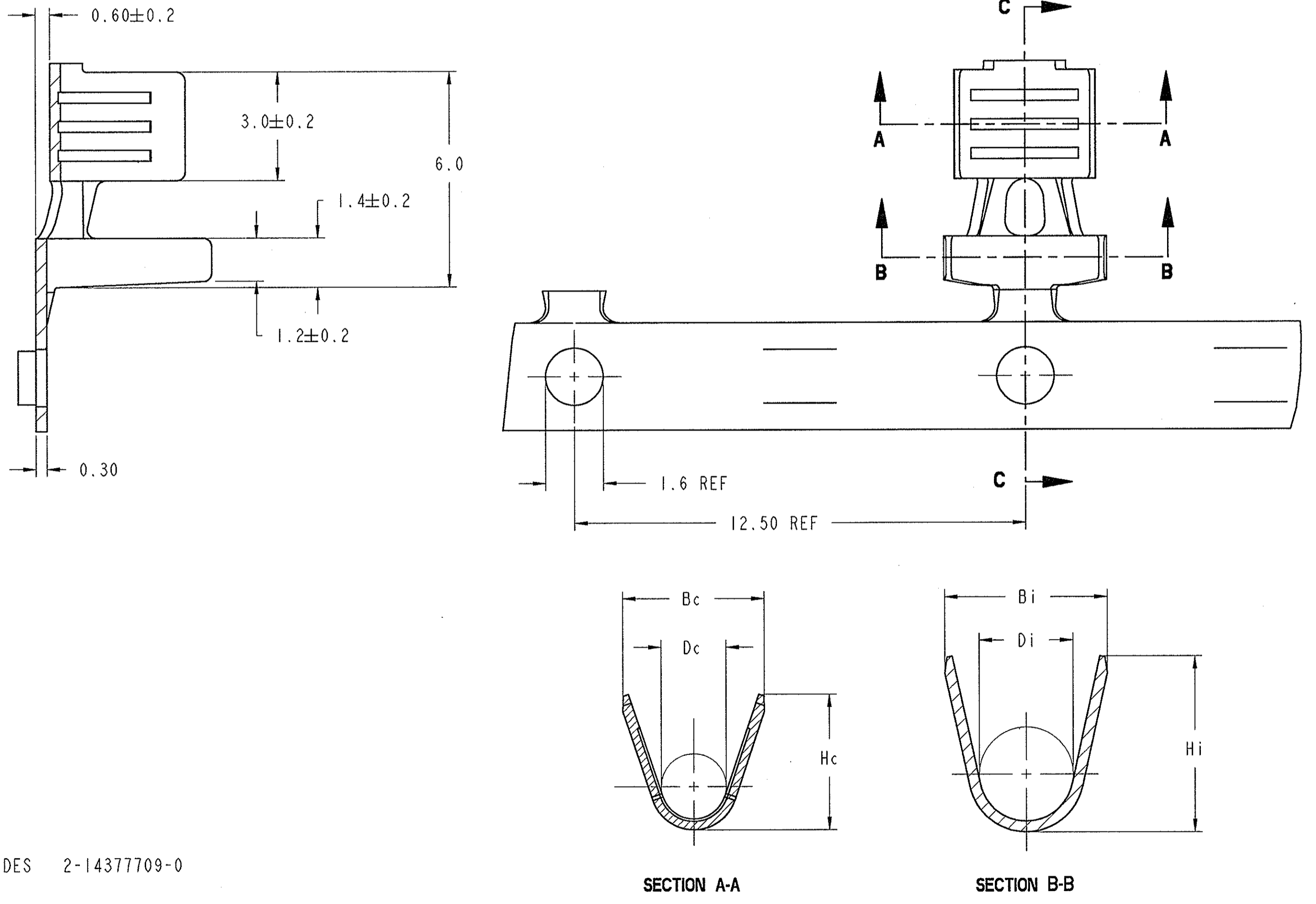

- 1 SUPERSEDES 2-1437709-0
- 2 SUPERSEDES 2-1437709-1
- 3 1-1437709-7 - OBSOLETE

PART AS SUPPLIED								COMPONENTS			MATERIALS			COMPONENTS SUPPLIED APART		TO FIT IN CAVITY	
P/N	PART REV.	DESCRIPTION	WATERPROOF	WIRE CROSS SEC. AREA	CRIMP CODE	CRIMP SPEC.	WEIGHT	TERMINAL	SLEEVE	WIRE SEAL	TERMINAL	SLEEVE	GREASE	WIRE SEAL	TYPE	DESCRIPTION	
0-1437709-9		TERMINAL FEMALE GOLD PLT.		0.22-0.35mm ²			0.402gr.	I	I	SEE CHART	DIN 17670 (CuSn6)	ALLOY 230 RICH LOW BRASS	INORGANIC GELLED SYNTHETIC HYDROCARBON OIL	1-1437713-1 (0.22-0.35)	AC/T/19/95	CAVITY TERMINAL FEMALE	
1-1437709-0	A	TERMINAL FEMALE GOLD PLT.	YES	0.50-1.00mm ²		AC/T/18/95	0.422gr.	I	I								
1-1437709-7		TERMINAL FEMALE GOLD PLT.		1.50-2.50mm ²			0.443gr.	I	I								
0-1437709-9		TERMINAL FEMALE GOLD PLT.		0.22-0.35mm ²			0.402gr.	I	I	NOT USED	(A)	TIN PLATED MATTE					
1-1437709-0	A	TERMINAL FEMALE GOLD PLT.	NO	0.50-1.00mm ²		AC/T/18/95	0.422gr.	I	I								
1-1437709-7		TERMINAL FEMALE GOLD PLT.		1.50-2.50mm ²			0.443gr.	I	I								

DIMENSIONS: 		TOLERANCES UNLESS OTHERWISE SPECIFIED: 0 PLC ± 1 PLC ±0.3 2 PLC ±0.1 3 PLC ± 4 PLC ± ANGLES ±1° FINISH -		OWN: M. PALMA CHK: R. MARTINI APVD: A. GENTA DATE: 20 JUN 2007 NAME:	TE Connectivity 1,6 SYSTEM TERMINAL FEMALE GOLD PLATED
MATERIAL:		WEIGHT:		SIZE: A1 CAGE CODE: 00779 DRAWING NO: 1418069 RESTRICTED TO:	
CUSTOMER DRAWING		SCALE: 10:1		SHEET: 2 OF 2 REV: P1	

单击下面可查看定价，库存，交付和生命周期等信息

[>>TE Connectivity\(泰科\)](#)