

THIS DRAWING IS UNPUBLISHED. RELEASED FOR PUBLICATION
 © COPYRIGHT BY TYCO ELECTRONICS CORPORATION. ALL RIGHTS RESERVED.

LOC	DIST	REVISIONS			
P	LTR	DESCRIPTION	DATE	DWN	APVD
AF	50	G	REVISED PER 0G3A-0750-02	18DEC02	MF KR

1 CONTINUOUS STRIP ON REELS WITH TERMINALS LOCATED ON 9.14 ± 0.08 [.360 ± .003] CENTERS.
 △ FOR OPTIMUM RETENTION FORCE IN POKE-IN TYPE MAG-MATE TERMINALS, ONE OF THE SERRATIONS AS SHOWN MUST BE ENGAGED WITH THE EDGE OF THE LEAF.

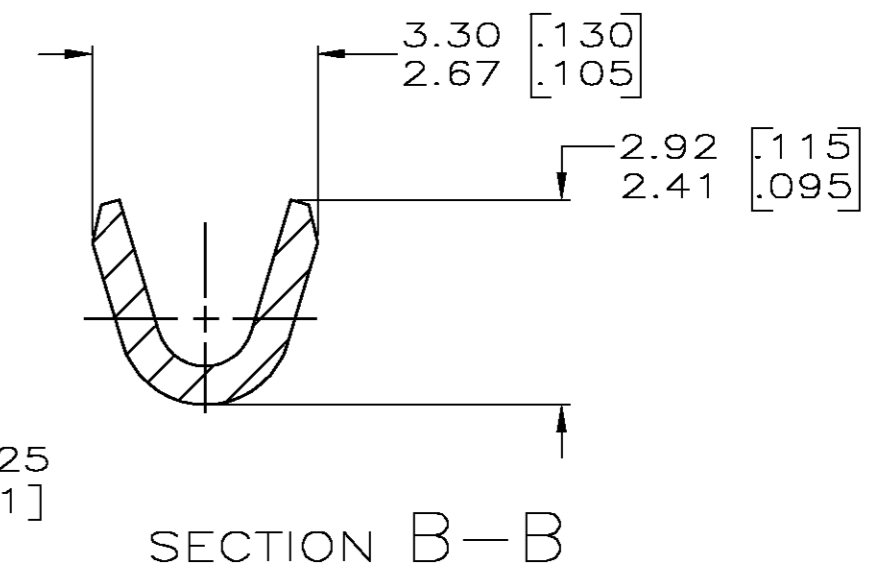
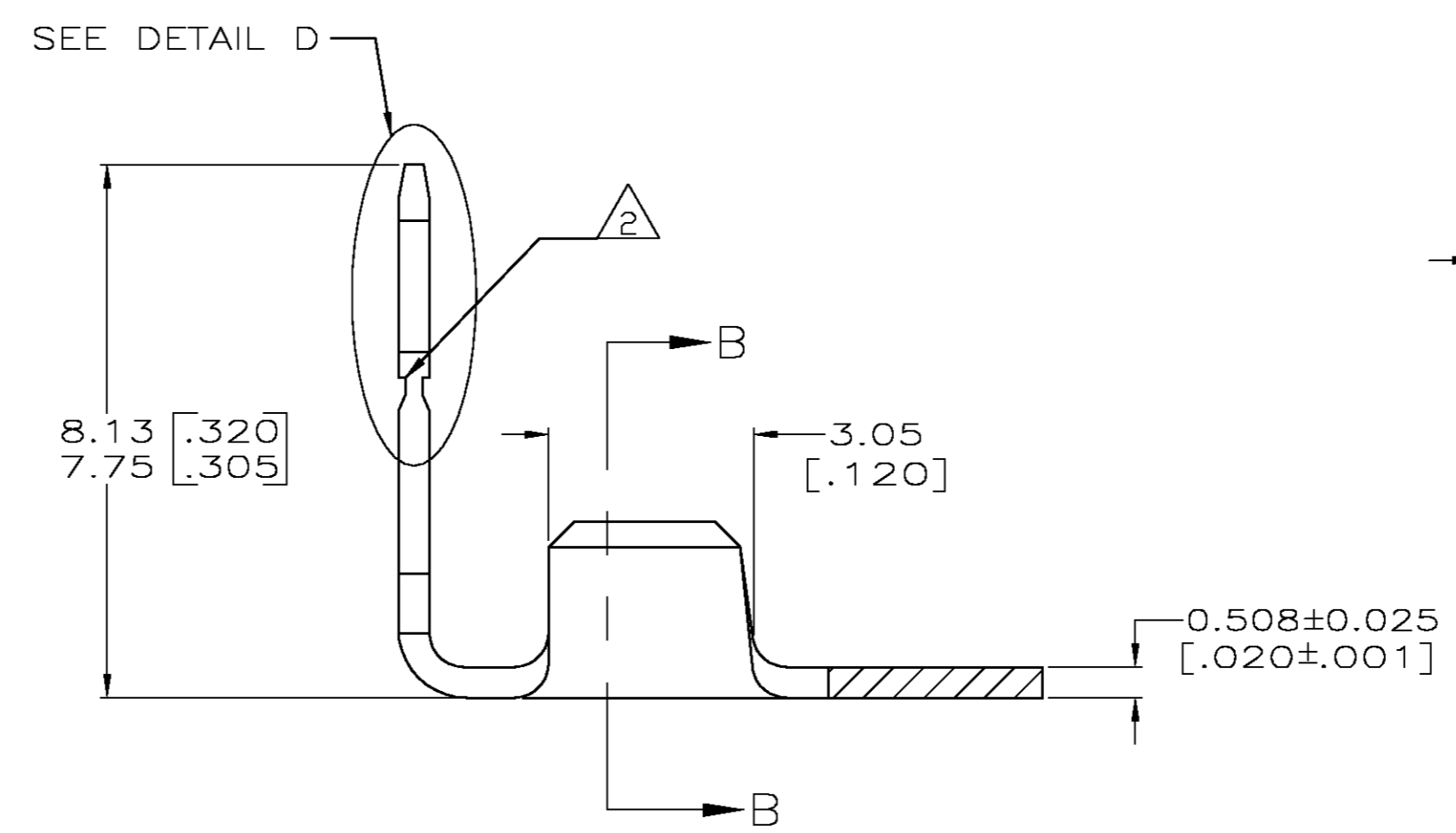
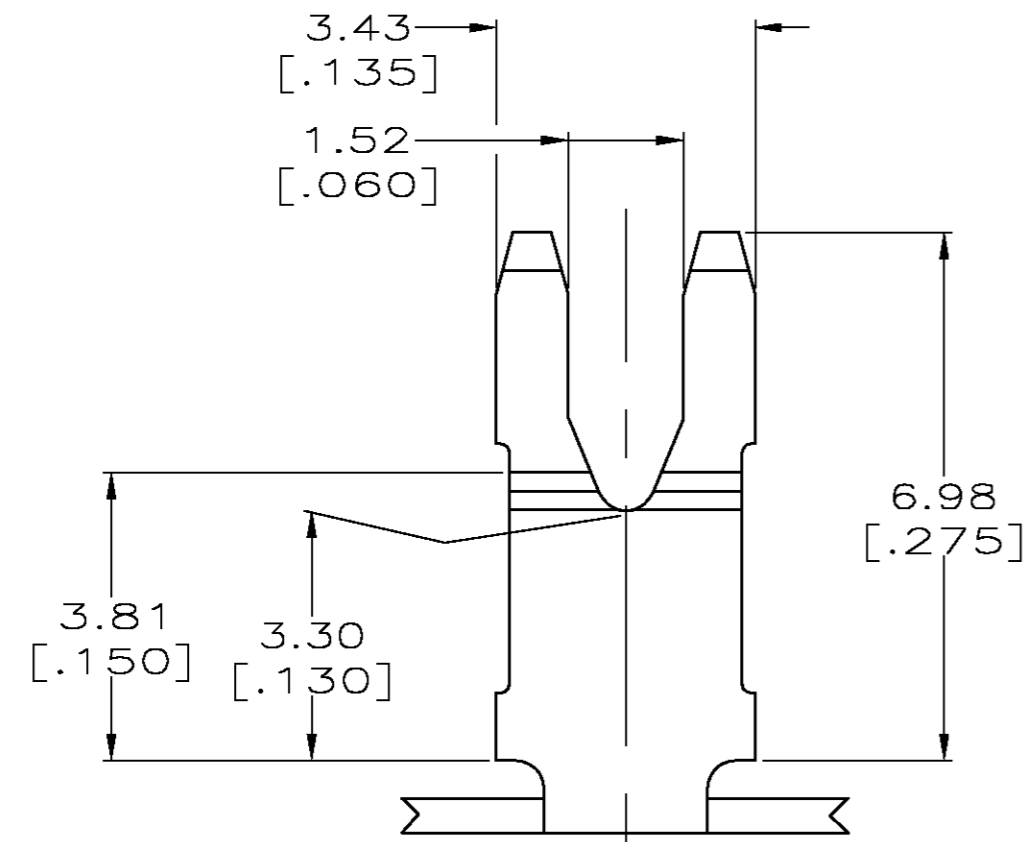
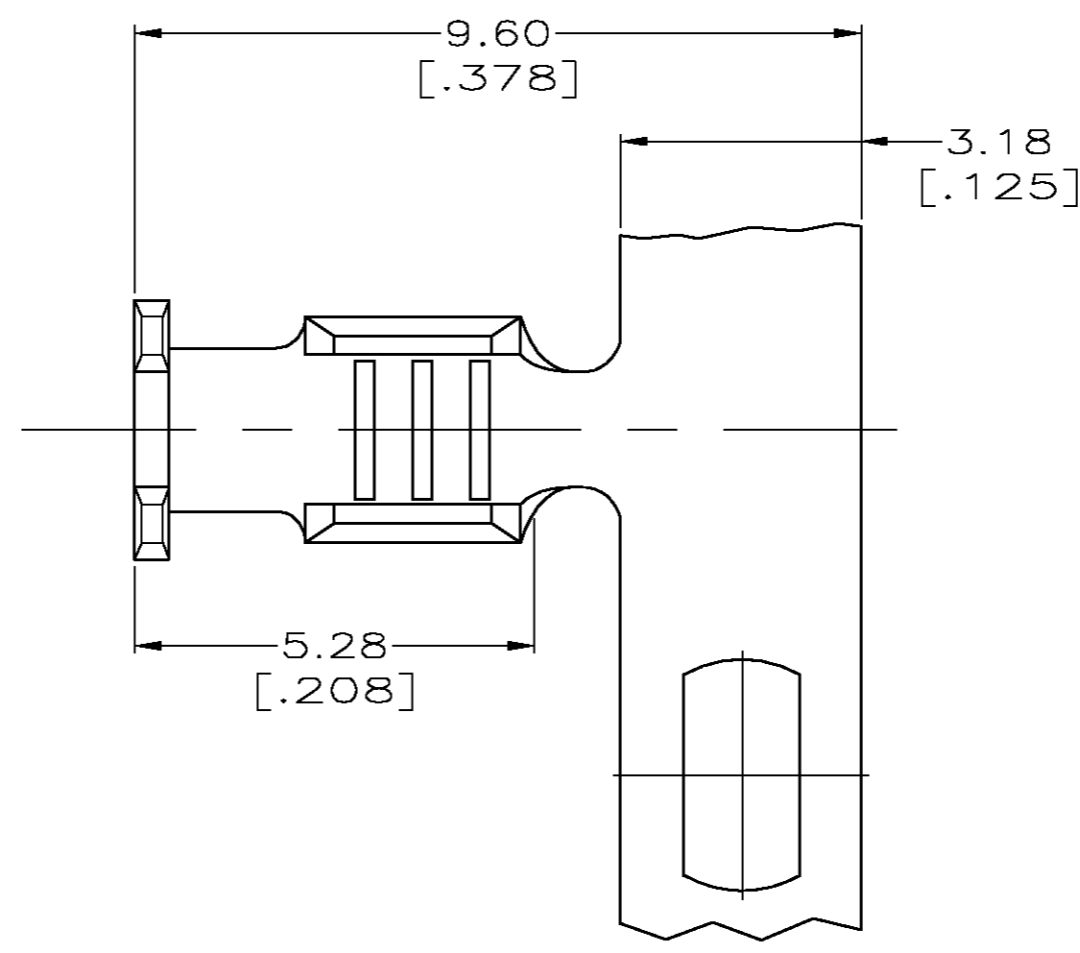
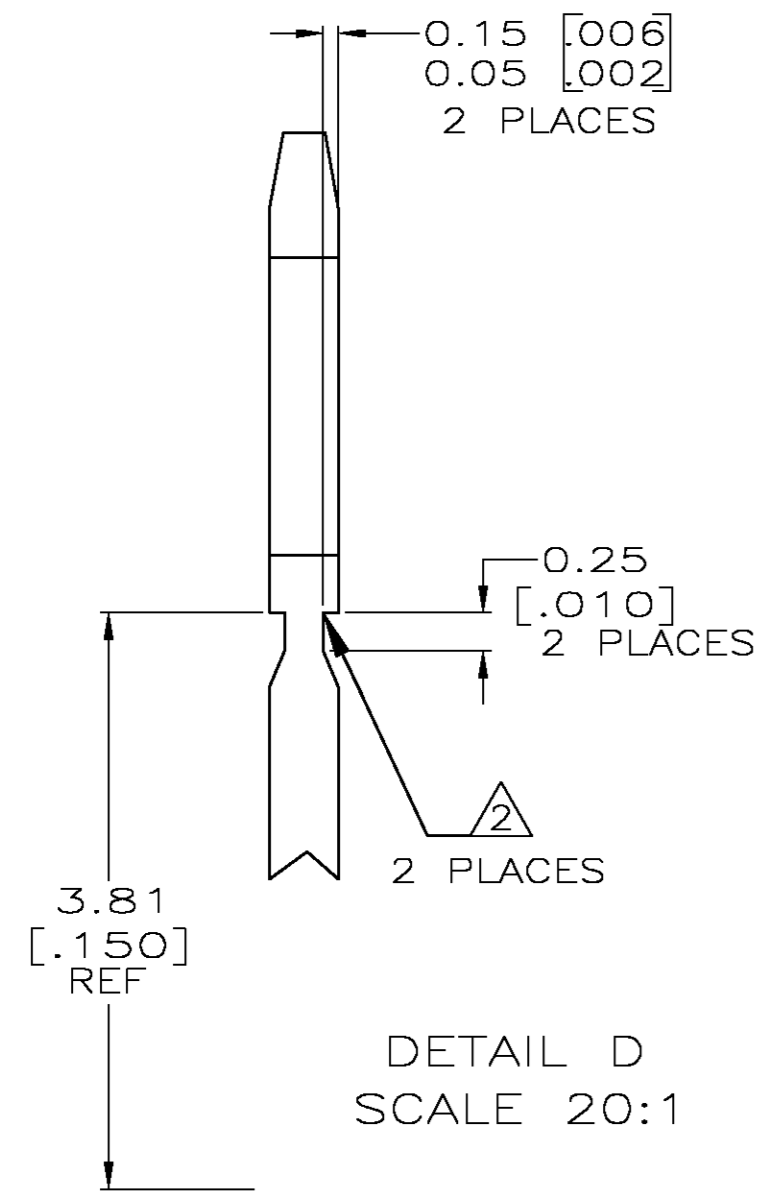

0.3-0.8mm ² [#22-18 AWG]	63410-1
WIRE RANGE	PART NUMBER

THIS DRAWING IS A CONTROLLED DOCUMENT.		DWN	JR RUTH	15NOV01	 Tyco Electronics Corporation Harrisburg, PA 17105-3608	
DIMENSIONS: MM		CHK	MICHAEL S. FEHER	15NOV01		
TOLERANCES UNLESS OTHERWISE SPECIFIED:		APVD	KURT A. RANDOLPH	15NOV01		
0 PLC ± - 1 PLC ± - 2 PLC ± 0.25 [.010] 3 PLC ± - 4 PLC ± - ANGLES ± -		NAME	-			
MATERIAL: 082 BRASS		PRODUCT SPEC	108-22055		SIZE	A2
FINISH: 0.000381 [.000015] MIN PRE-TIN PLATE		APPLICATION SPEC	114-2050		CAGE CODE	00779
CUSTOMER DRAWING		WEIGHT	-		DRAWING NO	C=63410
		SCALE	10:1		SHEET	1 OF 1
		REV	G			

单击下面可查看定价，库存，交付和生命周期等信息

[>>TE Connectivity\(泰科\)](#)