

REVISION(S)			
LTR	DESCRIPTION	INIT	APP'D
A	ECR-06-001164	E.T 1/17/06	C.W 1/20/06

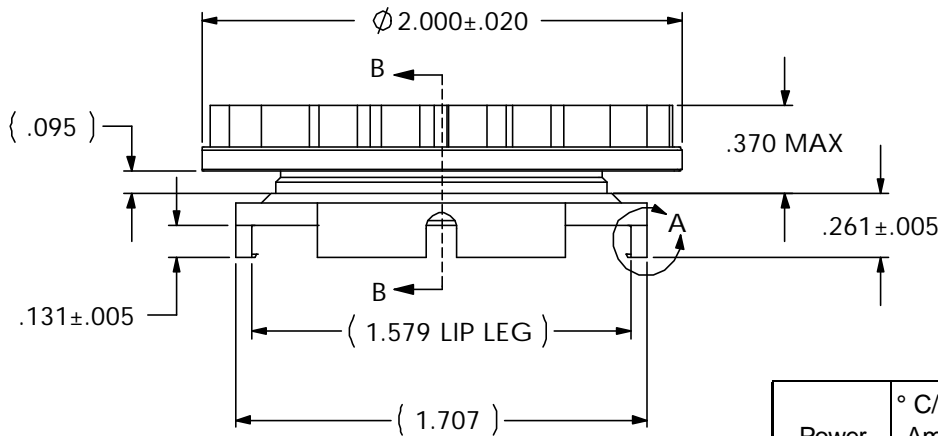

Ø 1 3/8" - 27 UNF -2A
THREAD

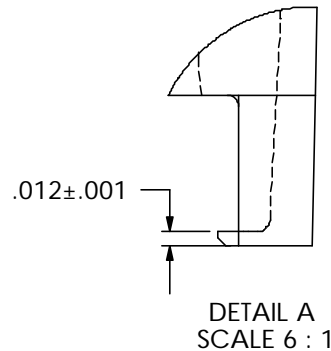
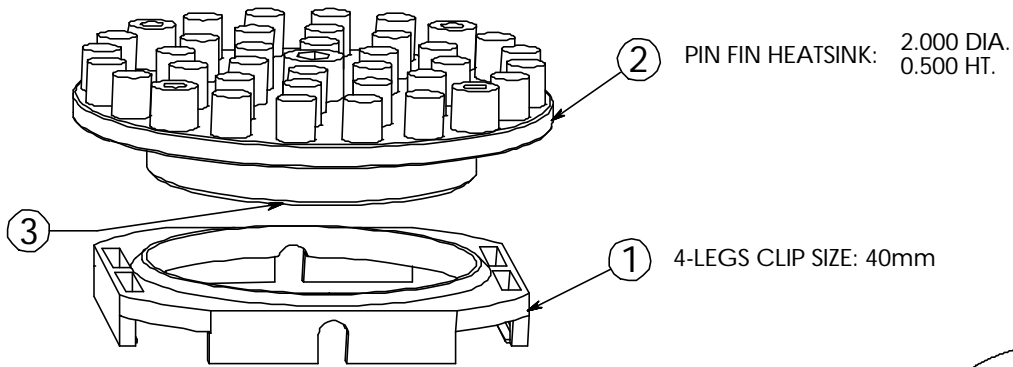
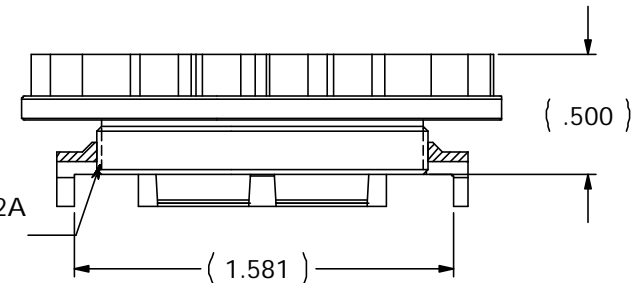

SECTION B-B

Power	° C/W @ Ambient	° C/W @ 200 LFM	° C/W @ 400 LFM	° C/W @ 600 LFM
5 Watts	8.64	4.45	2.80	2.00
10 Watts	7.86	4.49	2.89	2.38
15 Watts	7.38	4.57	2.95	2.42

CUSTOMER DRAWING	
SPECIFICATIONS ARE SUBJECT TO CHANGE WITHOUT NOTICE	

ITEM	DESCRIPTION	QTY	DO NOT SCALE
1	MOUNTING CLIP	1	tyco / Electronics Attleboro Falls Massachusetts 02763 UNLESS OTHERWISE SPECIFIED TOLERANCES ARE: .XX ± . .XXX ± . .XXXX ± . ANGLES ± °
2	HEAT SINK	1	
3	INTERFACE	1	

DRAWN BY: E.TAO		DATE: 1/17/06		MATERIAL: SEE NOTE	
ENGINEER: CS. WANG		DATE: 1/20/06		FINISH: SEE NOTE	
FILENAME	PROJECT	SYSTEM			

CONFIDENTIAL PROPERTY OF TYCO ELECTRONICS. NOT TO BE DISCLOSED TO OTHERS. REPRODUCED OR USED FOR ANY PURPOSES EXCEPT AS AUTHORIZED IN WRITING BY AN AUTHORIZED OFFICIAL OF TYCO. MUST BE RETURNED TO TYCO ON DEMAND, ON COMPLETION OF ORDERS OR OTHER PURPOSES FOR WHICH LENT.		TITLE: 40mm HEATSINK ASSEMBLY (HTS353NF-U)	
DIMENSIONS ARE IN: INCHES	SCALE: 1.25:1	PART NO: 9-1542001-7	SHEET: 1 OF 1
THIRD ANGLE PROJECTION	SIZE: A	DWG. NO. C-9-1542001-7	REV: A

单击下面可查看定价，库存，交付和生命周期等信息

[>>TE Connectivity\(泰科\)](#)