

THIS DRAWING IS UNPUBLISHED. RELEASED FOR PUBLICATION
 © COPYRIGHT BY TYCO ELECTRONICS CORPORATION. ALL RIGHTS RESERVED.

LOC		DIST		REVISIONS			
P	LTR	DESCRIPTION	DATE	DWN	APVD		
AD	00	B	ECO-06-000904	16OCT2007	RB	MS	

SPECIFICATIONS
 MAKE-BEFORE-BREAK

MATERIALS:
 ACTUATOR, BASE & COVER- NYLON 66 UL94V-0, BLACK
 TERMINAL BOARD- PHENOLIC, NATURAL
 TERMINAL/FIXED CONTACT- COPPER ALLOY- SILVER OVER NICKEL PLATE
 MOVING CONTACT- COPPER ALLOY- SILVER OVER NICKEL PLATE
 SEAL- EPOXY

ELECTRICAL:
 CONTACT RATING- 100mA@12V DC
 INITIAL CONTACT RESISTANCE- 30MILLIOHM MAX.
 FINAL CONTACT RESISTANCE- 100MILLIOHM MAX. (AFTER TEST)
 INSULTAION RESISTANCE- 100MEGOHMS MIN.
 DIELECTRIC STRENGTH- 500V RMS@SEA LEVEL
 LIFE EXPECTANCY- 10,000 CYCLES MIN.

MECHANICAL:
 ACTUATION FORCE- 250 +200/-150 GRAMS
 TRAVEL- 2.00±0.50 [.079±.020]

ENVIRONMENTAL:
 OPERATING TEMPERATURE- -20° TO +70°C
 STORAGE TEMPERATURE- -30° TO +70°C
 RESISTANCE TO SOLDER HEAT- 260° FOR 5 SEC. PER 109-202, CONDITION C
 SOLDERABILITY PER EIA-364-52, CLASS 2, CATEGORY 1, 95% MIN COVERAGE

NOTES:
 1. ALL MATERIALS AND FINISHES SHALL COMPLY WITH EU DIRECTIVE 2002/95/EC OF 27JAN2003 (ROHS)

- △ ANTI SOLDER WICK SEAL AT TERMINAL TO BOARD INTERFACE
- 3. ALL TESTING COMPLETED PER 202-2469 TEST SPECIFICATION

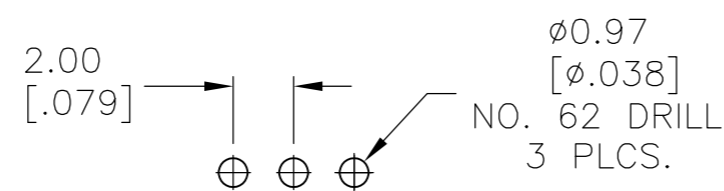
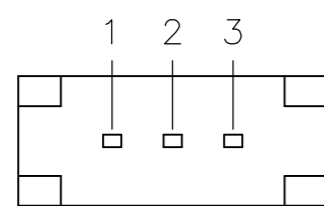
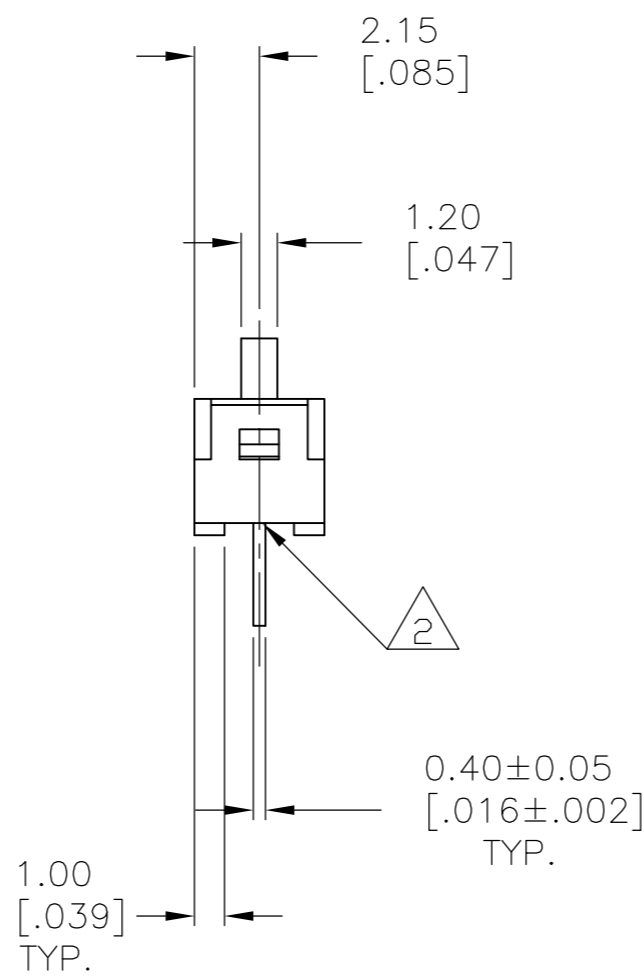
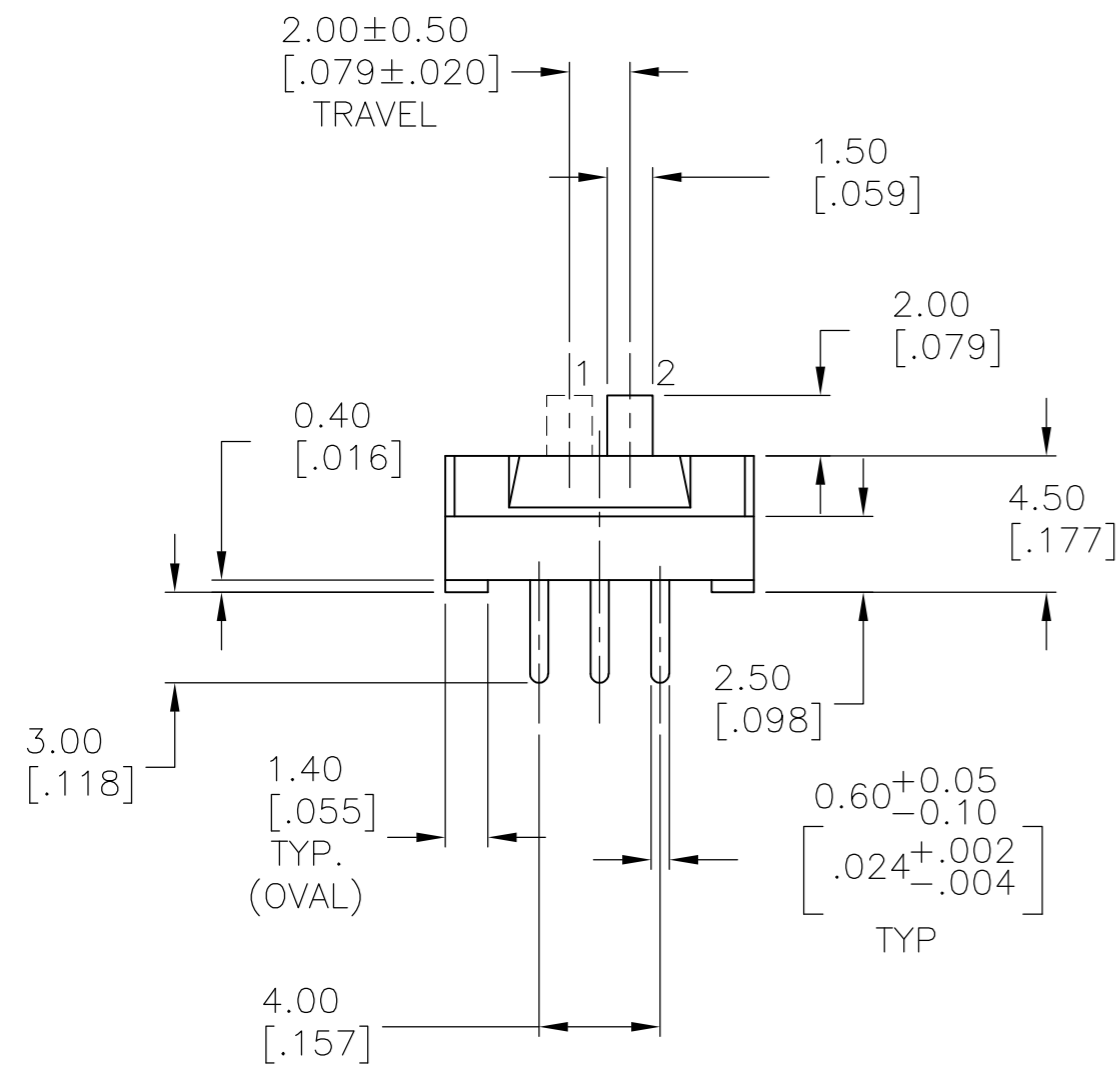
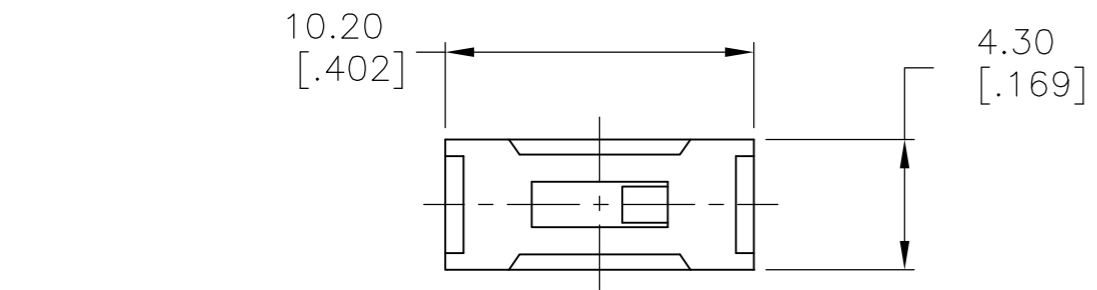

PCB HOLE LAYOUT
 TOLERANCE ON P.C. LAYOUT
 DIMENSIONS TO BE : ±.002

PART NO.	MODEL NO.	POS. 1	POS. 2
1825280-1	SSJ1204	2 TO 1	2 TO 3

TERMINALS CONNECTED WHEN SLIDER IS IN THE POSITION SHOWN.
 NOTE: TERMINAL NUMBERS ARE FOR REFERENCE ONLY AND DO NOT APPEAR ON SWITCHES.

THIS DRAWING IS A CONTROLLED DOCUMENT.		DWN SUDHEER 16MAY06	Tyco Electronics Corporation Harrisburg, Pa 17105-3608	
DIMENSIONS: mm [INCHES]	TOLERANCES UNLESS OTHERWISE SPECIFIED:	CHK M. SARVER	NAME	
	0 PLC ± -	APVD M. SARVER	PRODUCT SPEC	
	1 PLC ± -	APPLICATION SPEC	SIZE CAGE CODE DRAWING NO RESTRICTED TO	
	2 PLC ± -	WEIGHT -	A2 00779 C=1825280	
	3 PLC ± 0.25[.010]	FINISH -	SCALE 4:1 SHEET 1 OF 1 REV B	
MATERIAL SEE SPECIFICATIONS	FINISH -	CUSTOMER DRAWING		

单击下面可查看定价，库存，交付和生命周期等信息

[>>TE Connectivity\(泰科\)](#)