

THIS DRAWING IS UNPUBLISHED.

RELEASED FOR PUBLICATION

© COPYRIGHT - By -

ALL RIGHTS RESERVED.

LOC
E

DIST
B

REVISIONS

P	LTR	DESCRIPTION	DATE	DWN	APVD
D1		REVISED PER ECO-11-005150	21MAR11	RK	HMR

NOTES:

- ELECTRICAL DATA: CONTACT RESISTANCE: 10 mOhm MAX
INSULATION RESISTANCE: 100 MOhm MIN at 500VDC
CURRENT RATING: 5 AMPS FOR 3 AND 4 POSITIONS
BREAKDOWN VOLTAGE: 500 VAC MIN PER MINUTE
- ENVIRONMENTAL: OPERATING TEMPERATURE: -25°C TO +90°C
SEALING REQUIREMENTS: IP67
- PROD SPEC: 108-3641
- PACKAGING: 107-3334
- FOR TECHNICAL DATA REFER TO YOUR LOCAL TE CONNECTIVITY SALES OFFICE.
- ALL DIMENSIONS ARE NOMINAL FOR REFERENCE ONLY UNLESS OTHERWISE STATED.

ITEM	DESCRIPTION	MATERIAL	FINISH/COLOUR	QUANTITY / ITEM	
				-1	-2
1	CONNECTOR HOUSING	GF NYLON	BLACK	1	1
2	PIN CONTACT	BRASS	0.15µm GOLD OVER NICKEL	3	4
3	CONNECTOR BODY	ZINC DIE CAST	2.5µm NICKEL PLATED	1	1
4	'O' RING	EPDM	BLACK	1	1
5	SCREW NUT	BRASS	2.5µm NICKEL PLATED	1	1

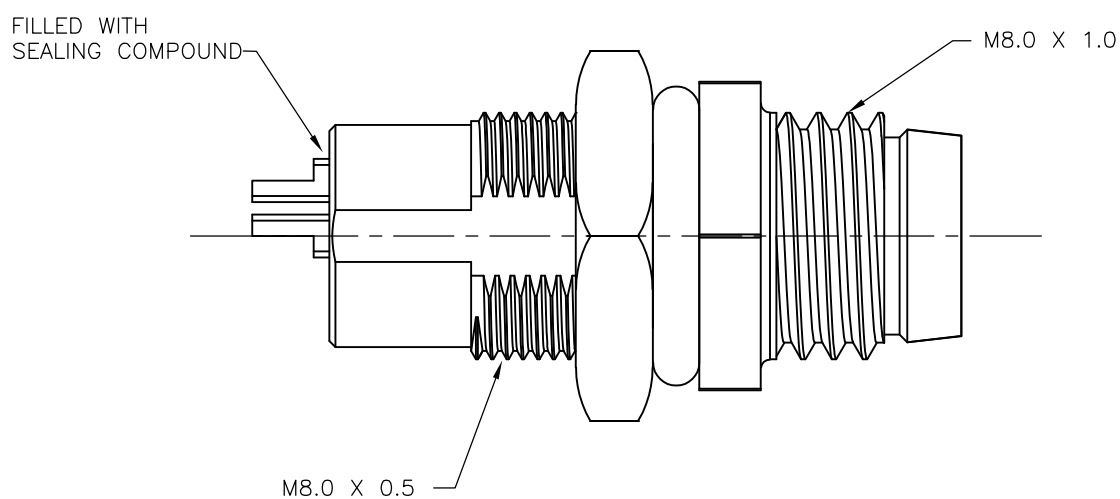
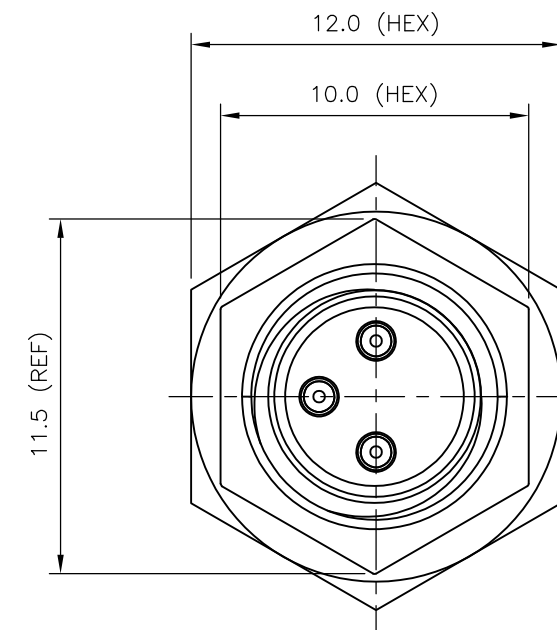
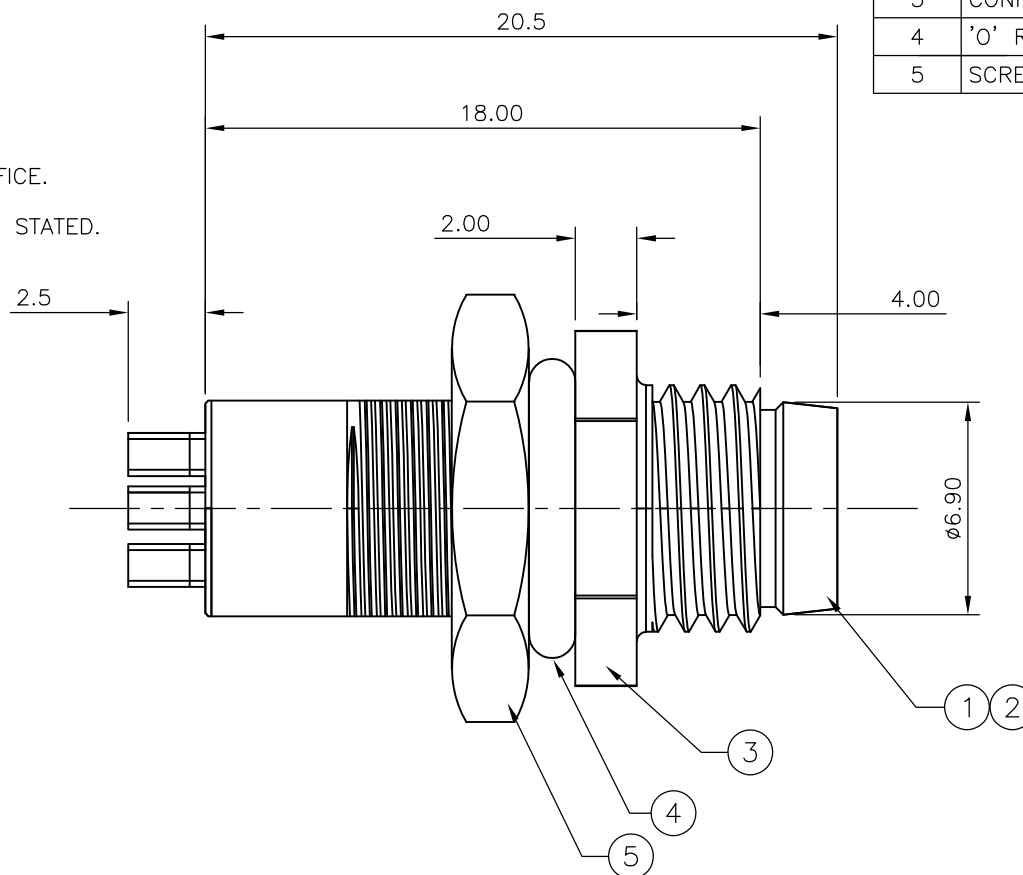
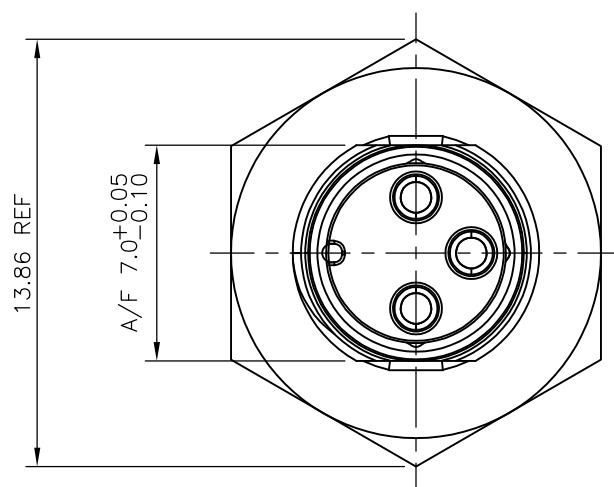

DESCRIPTION	NO. OF POS	PART NUMBER
M8 METAL MALE PANEL MOUNT CONNECTOR, SOLDER, STRAIGHT, REAR (HEXAGONAL) MOUNTING	4	1838838-2
M8 METAL MALE PANEL MOUNT CONNECTOR, SOLDER, STRAIGHT, REAR (HEXAGONAL) MOUNTING	3	1838838-1

THIS DRAWING IS A CONTROLLED DOCUMENT.		DWN A.Morey 21FEB07	STE TE Connectivity	
DIMENSIONS: mm		CHK F.Wheeler-King 22FEB07		
TOLERANCES UNLESS OTHERWISE SPECIFIED:		APVD F.Wheeler-King 22FEB07	NAME M8 METAL MALE PANEL MOUNT CONNECTOR, SOLDER, STRAIGHT, REAR (HEXAGONAL) MOUNTING	
0 PLC ± -		PRODUCT SPEC	SIZE	
1 PLC ± -		APPLICATION SPEC	CAGE CODE	DRAWING NO
2 PLC ± -		WEIGHT	RESTRICTED TO	
3 PLC ± -			A3 00779 C-1838838	
4 PLC ± -			SCALE	SHEET
ANGLES ± -			NTS	1 OF 2
FINISH			REV	D1
MATERIAL			CUSTOMER DRAWING	

THIS DRAWING IS UNPUBLISHED. RELEASED FOR PUBLICATION
 © COPYRIGHT - By - ALL RIGHTS RESERVED.

LOC	DIST	REVISIONS			
P	LTR	DESCRIPTION	DATE	DWN	APVD
	-	SEE SHEET 1	-	-	-

1838838-1

1838838-2

PIN ASSIGNMENTS
FRONT VIEW

PIN ASSIGNMENTS
FRONT VIEW

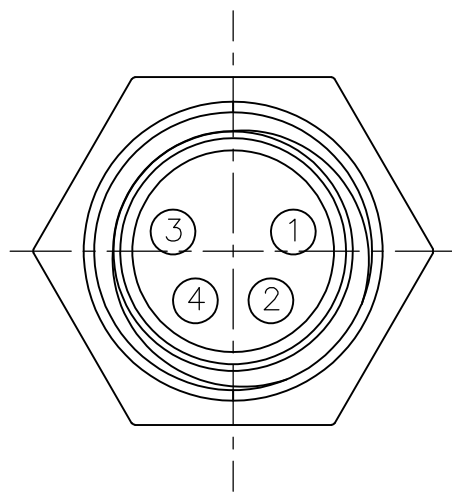
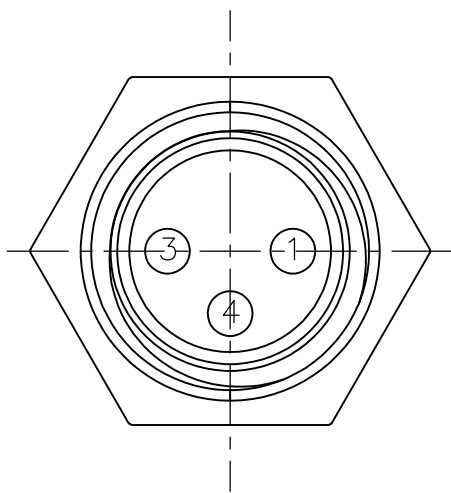

RECOMMENDED PANEL CUT-OUT
(MAX PANEL THICKNESS 3mm)

RECOMMENDED PANEL CUT-OUT
(MAX PANEL THICKNESS 3mm)

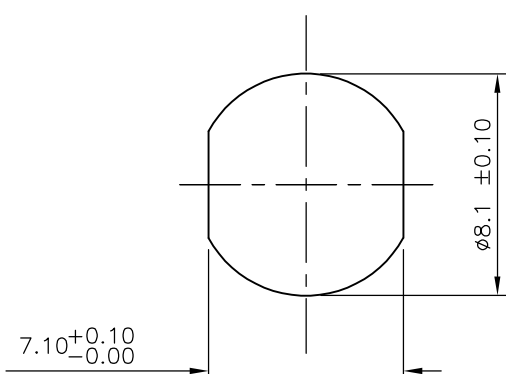
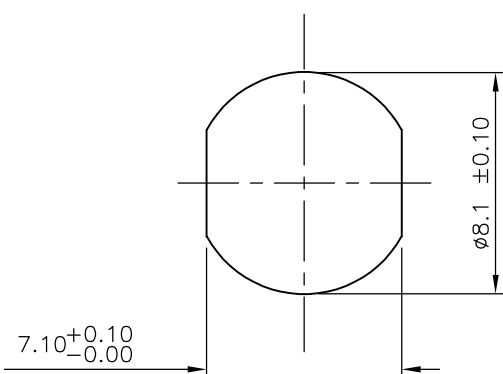

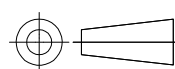
THIS DRAWING IS A CONTROLLED DOCUMENT.		DWN A. Morey 21FEB07	 TE Connectivity		
DIMENSIONS: mm		CHK F. Wheeler-King 22FEB07			
		APVD F. Wheeler-King 22FEB07	NAME M8 METAL MALE PANEL MOUNT CONNECTOR, SOLDER, STRAIGHT, REAR (HEXAGONAL) MOUNTING		
TOLERANCES UNLESS OTHERWISE SPECIFIED:		PRODUCT SPEC	RESTRICTED TO		
0 PLC ± -		APPLICATION SPEC	SIZE	CAGE CODE	DRAWING NO
1 PLC ± -			A300779		C-1838838
2 PLC ± -			SCALE NTS SHEET 2 OF 2 REV D1		
3 PLC ± -					
4 PLC ± -					
ANGLES ± -					
FINISH		WEIGHT			
-		-	CUSTOMER DRAWING		

单击下面可查看定价，库存，交付和生命周期等信息

[>>TE Connectivity\(泰科\)](#)