

THIS DRAWING IS UNPUBLISHED. RELEASED FOR PUBLICATION AUGUST ,2006.

© COPYRIGHT 2006 By - ALL RIGHTS RESERVED.

LOC	DIST	REVISIONS					
E	B	P	LTR	DESCRIPTION	DATE	DWN	APVD
		D		ECO-14-000688	31JUL2014	RZ	MY

NOTES:

1 PACKAGE ONE COMPLETE CONNECTOR IN HEAT SEALED, LABELED BAG/ 500 PER SHIPPING BOX. LABELED PER TEC-107-115

2 100 TRAY PACK IN ACCORDANCE WITH AMP SPEC 107-3275

3 Au PLATING

4 HAND TOOL : 9-1478240-0

5 DIE SET : 9-1478248-0

6 ELECTRICAL CHARACTERISTICS

FREQUENCY RANGE: DC - 6 GHz
 NOMINAL IMPEDANCE: 50 Ohm
 INSULATION RESISTANCE: 1000 MOhm
 WORKING VOLTAGE: 335 Volts RMS at Sea Level
 DIELECTRIC WITHSTAND VOLTAGE: 1000 Volts RMS Max
 CONTACT RESISTANCE:
 CENTRE CONTACT: 5.00 mOhm Max
 OUTER CONTACT: 2.50 mOhm Max
 VSWR @ 4GHz: 1.63:1 Max
 INSERTION LOSS dB @ x 1.0 GHz: 0.20 Max

7 MECHANICAL CHARACTERISTICS

CABLE RETENTION FORCE:
 "RG174A/U, 188A/U, 316/U, URM95:" 53N Min
 DURABILITY: 500 Cycles Min

8 ENVIRONMENTAL CHARACTERISTICS

OPERATING TEMPERATURE: -65 to +165 DegC

9 FOR TECHNICAL DATA REFER TO YOUR LOCAL TE CONNECTIVITY SALES OFFICE

10 ALL DIMENSIONS ARE NOMINAL FOR REFERENCE ONLY UNLESS OTHERWISE STATED

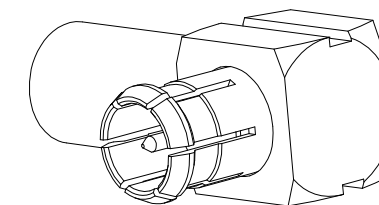

SCALE: NTS

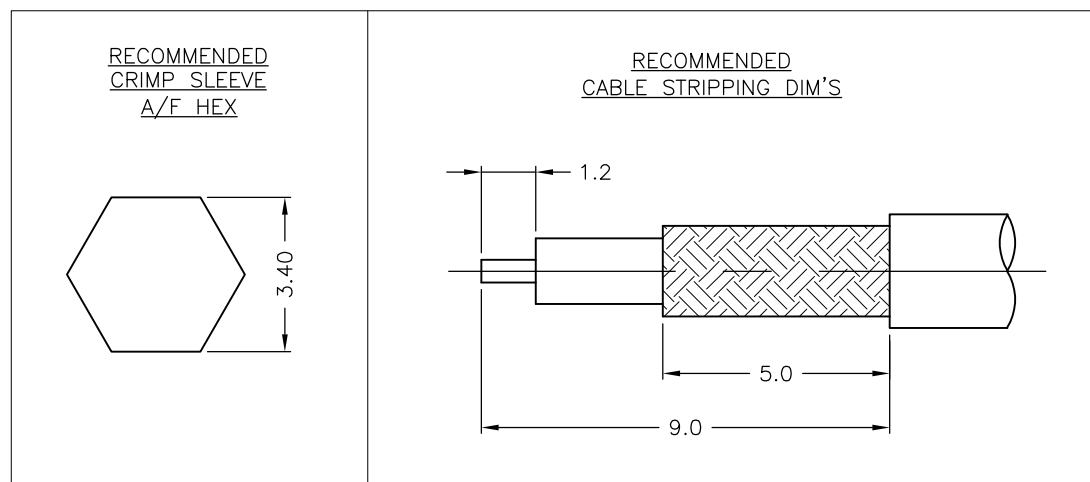
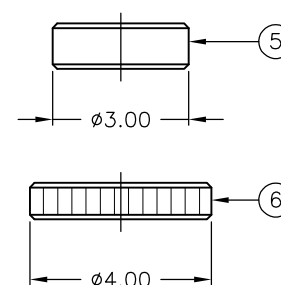
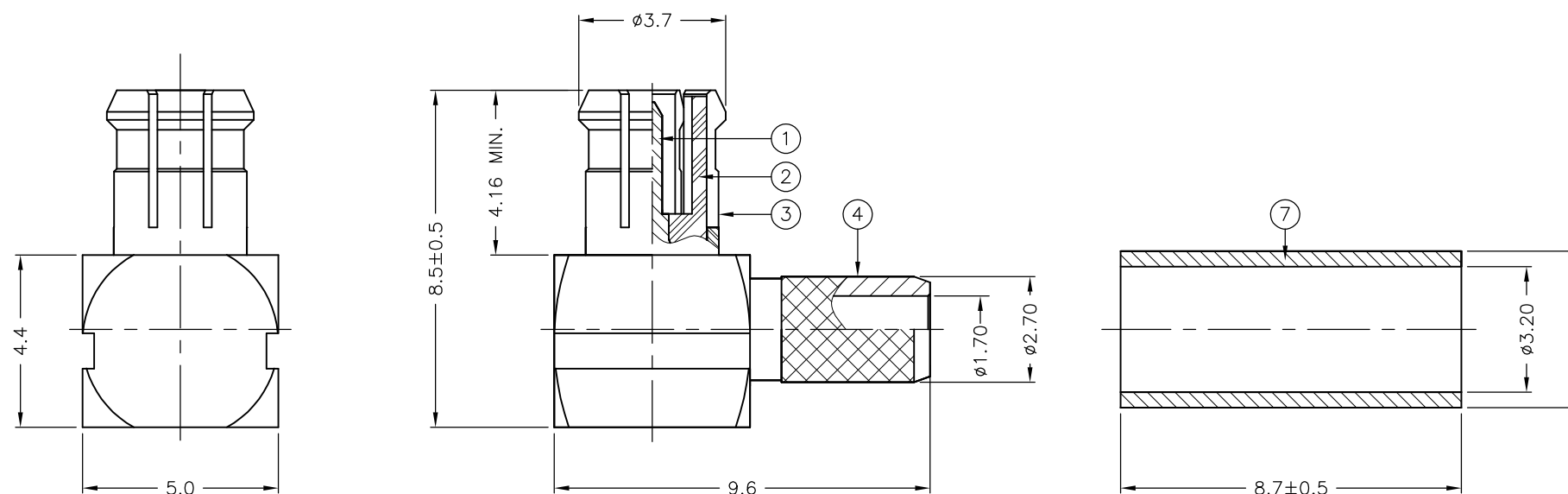

QTY	QTY	MATERIAL	PLC	DESCRIPTION	ITEM
1	1	BRASS	3	FERRULE	7
1	1	BRASS	3	CAP	6
1	1	PTFE		INSULATION	5
1	1	BRASS	3	BODY II	4
1	1	BERYLLIUM COPPER	3	BODY I	3
1	1	PTFE		INSULATION	2
1	1	BRASS	3	CONTACT	1
6--0	1--0			MATERIAL	DESCRIPTION
					ITEM

THIS DRAWING IS A CONTROLLED DOCUMENT.		DWN RITA ZUO 02 AUG 2010	TE Connectivity MCX ELBOW PLUG CRIMP 50 OHM RG174A/U, 188A/U, 316/U	
DIMENSIONS: mm		CHK ANSON MA 02 AUG 2010		
TOLERANCES UNLESS OTHERWISE SPECIFIED:		APVD JONGSENG GOH 02 AUG 2010		
0 PLC ± - 1 PLC ± 0.2 2 PLC ± 0.1 3 PLC ± - 4 PLC ± - ANGLES ± -		PRODUCT SPEC 108-3640		
MATERIAL SEE TABLE	FINISH -	APPLICATION SPEC 411-3251	NAME	RESTRICTED TO
		WEIGHT -	SIZE A3	CAGE CODE 00779
		CUSTOMER DRAWING	DRAWING NO C-1337585	SCALE NTS
			SHEET 1 OF 1	REV D

单击下面可查看定价，库存，交付和生命周期等信息

[>>TE Connectivity\(泰科\)](#)