

THIS DRAWING IS UNPUBLISHED.  
VERTRAULICHE UNVERÖFFENTLICHTE ZEICHNUNG  
© COPYRIGHT -

RELEASED FOR PUBLICATION  
FREI FUER VERÖFFENTLICHUNG  
ALL RIGHTS RESERVED.  
ALLE RECHTE VORBEHALTEN

PROJECT NO.:  
E92-52625

REVISIONS ÄNDERUNGEN					
P	LTR	DESCRIPTION BESCHREIBUNG	DATE	DWN	APVD
	A4	ECR-10-026307	20JAN11	KK	HMR
	A5	OBSOLETE 966292-7, 1-1, 1-2, 1-9, 2-2, 3-2	21FEB2018	SH	GN
	A6	ECO-19-003069	01OCT2019	RS	DR

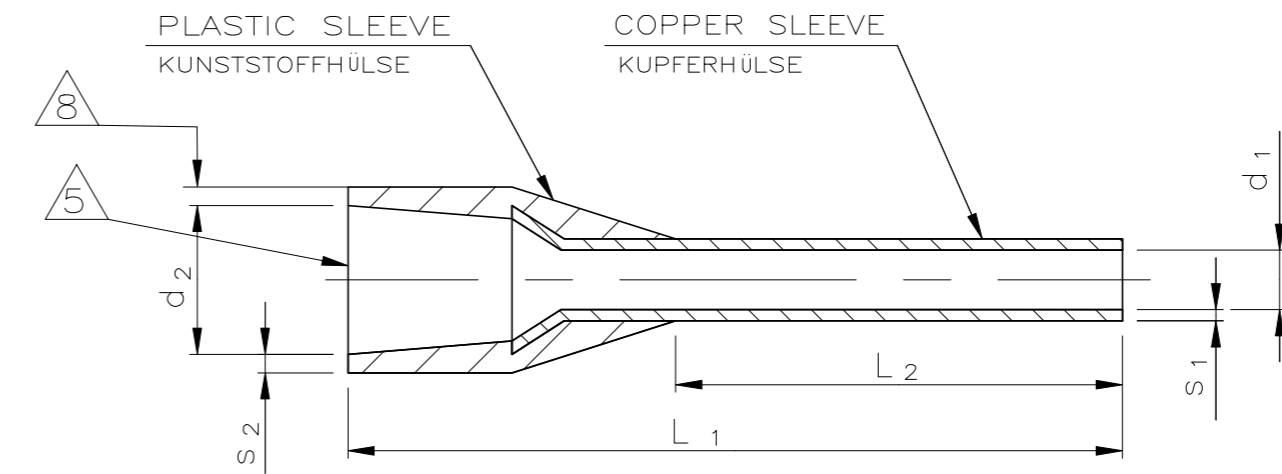

ORDER NO. BESTELL-NR.	CROSS-SECTION QUERSCHNITT		STRIP LENGTH ABISOLIER-LÄNGE	TYPE AUSFÜHRUNG	COLOUR FARBE	L <sub>1</sub>	L <sub>2</sub>	d <sub>1</sub>	s <sub>1</sub>	d <sub>2</sub>	s <sub>2</sub>	PACKING UNIT VERPACKUNGS-EINHEIT PIECES PER BAG STÜCK PRO BEUTEL
	mm <sup>2</sup>	AWG										
966 292-1	0.14	26	8	NORMAL	BROWN	10 ±1.5	6 ±0.4	0.7 +0.14	0.15 ±0.05	1.6 ±0.2	0.25 ±0.10	500
966 292-2	0.14	26	8	LONG	BROWN	12 ±1.5	8 ±0.4	0.7 +0.14	0.15 ±0.05	1.6 ±0.2	0.25 ±0.10	500
966 292-9	0.50	20	12	SEMILONG	WHITE	16 ±1.5	10 ±0.4	1.0 +0.14	0.15 ±0.05	2.6 ±0.2	0.25 ±0.10	500
1-966 292-5	1.00	17	10	NORMAL	RED	14 ±1.5	8 ±0.4	1.4 +0.14	0.15 ±0.05	3.0 ±0.2	0.25 ±0.10	500
1-966 292-6	1.00	17	12	SEMILONG	RED	16 ±1.5	10 ±0.4	1.4 +0.14	0.15 ±0.05	3.0 ±0.2	0.25 ±0.10	500
2-966 292-4	4.00	11	11	NORMAL	ORANGE	17 ±1.5	10 ±0.4	2.8 +0.25	0.20 ±0.05	4.8 ±0.4	0.30 ±0.10	500
2-966 292-6	4.00	11	20	LONG	ORANGE	26 ±2.0	18 ±0.6	2.8 +0.25	0.20 ±0.05	4.8 ±0.4	0.30 ±0.10	500
2-966 292-7	6.00	10	14	NORMAL	GREEN	20 ±1.5	12 ±0.6	3.5 +0.30	0.20 ±0.05	6.3 ±0.4	0.30 ±0.10	100
2-966 292-9	10.00	7	15	NORMAL	BROWN	22 ±2.0	12 ±0.6	4.5 +0.30	0.20 ±0.05	7.6 ±0.4	0.40 ±0.15	100
3-966 292-0	10.00	7	21	LONG	BROWN	28 ±2.0	18 ±0.6	4.5 +0.30	0.20 ±0.05	7.6 ±0.4	0.40 ±0.15	100
3-966 292-1	16.00	6	15	NORMAL	IVORY	24 ±2.0	12 ±0.6	5.8 +0.30	0.20 ±0.05	8.8 ±0.4	0.40 ±0.15	100
3-966 292-3	25.00	3	19	NORMAL	BLACK	30 ±2.0	16 ±0.6	7.3 +0.40	0.20 ±0.05	11.2 ±0.5	0.40 ±0.15	50
3-966 292-4	25.00	3	25	LONG	BLACK	36 ±2.0	22 ±0.6	7.3 +0.40	0.20 ±0.05	11.2 ±0.5	0.40 ±0.15	50
3-966 292-5	35.00	2	19	NORMAL	RED	30 ±2.0	16 ±0.6	8.3 +0.40	0.20 ±0.05	12.7 ±0.5	0.40 ±0.15	50
3-966 292-6	35.00	2	28	LONG	RED	39 ±2.0	25 ±0.6	8.3 +0.40	0.20 ±0.05	12.7 ±0.5	0.40 ±0.15	50
3-966 292-7	50.00	1	25	NORMAL	BLUE	36 ±2.0	20 ±0.6	10.3 +0.40	0.30 ±0.05	15.0 ±1.0	0.50 ±0.15	50
3-966 292-8	50.00	1	30	LONG	BLUE	40 ±2.0	25 ±0.6	10.3 +0.40	0.30 ±0.05	15.0 ±1.0	0.50 ±0.15	50

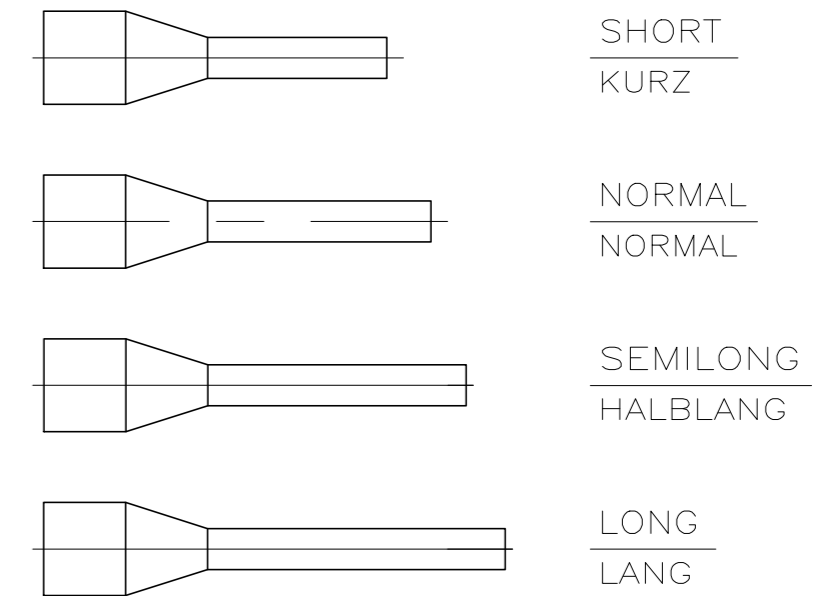

- 1 THE AWG CROSS-SECTION CAN DIFFER SLIGHTLY TO THE DIN-STANDARD CROSS-SECTION VALUES.
- 2 RECOMMENDED STRIP LENGTH
- 3 TUBULAR END-SLEEVES PACKED INTO PLASTIC BAG
- 4 COLOUR TYPE 1: COLOURS PER TELEMECANIQUE STANDARD
- 5 MAX.INSULATION DIA. OF WIRE: d<sub>2</sub> MIN.-0.1
- 6. USE HAND TOOL 539660-1
- 7. NOTE DELETED.
- 8 LENGTH "L1" INCLUDES MOLDING FLASH PRESENT IN THIS ZONE.

- 1 DER AWG-QUERSCHNITT KANN VON DEN DIN-NORM QUERSCHNITTSWERTEN GERINGFÜGIG ABWEICHEN.
- 2 EMPFOHLENE ABISOLIERLÄNGE
- 3 ADERENDHÜLSEN IN PLASTIKBEUTEL VERPACKT
- 4 FARBREIHE 1: FARBEN NACH TELEMECANIQUE STANDARD
- 5 MAX.ISOLATIONS-Ø DER LEITUNG:d<sub>2</sub> MIN.-0.1
- 6. BENUTZEN SIE HANDWERKZEUG 539660-1

THIS DRAWING IS A CONTROLLED DOCUMENT. DIESE ZEICHNUNG IST EIN KONTROLLIERTES DOKUMENT.		DWN R.SCHMIDT 10-NOV-93		
DIMENSIONS: MASSE/WEITEN: mm		CHK W.BÖCK 15-JUN-94		
	TOLERANCES UNLESS OTHERWISE SPECIFIED: ALLGEMEINTOLERANZEN	APVD G.FELDMEIER 29-NOV-00	NAME TUBULAR END-SLEEVE WITH PLASTIC SLEEVE COLOUR TYPE 1, NOT PER DIN ADERENDHUELSE MIT KUNSTSTOFFHUELSE FARBREIHE 1, NIEHT NACH DIN	
	0 PLC ± - 1 PLC ± - 2 PLC ± - 3 PLC ± - 4 PLC ± -	PRODUCT SPEC PRODUKTSPEZ. -	APPLICATION SPEC VERARBEITUNGSSPEZ. -	SIZE A2
MATERIAL PP/E-Cu	FINISH/OBERFL.: Sn COLOUR: SEE TABLE FARBE: SIEHE TABELLE	WEIGHT GEWICHT	DRAWING NO ZEICHNUNGS-NR. G=966292	RESTRICTED TO NUR FUER -
CUSTOMER DRAWING / KUNDENZEICHNUNG			SCALE MASSSTAB -	SHEET BLATT 1 OF 1

单击下面可查看定价，库存，交付和生命周期等信息

[>>TE Connectivity\(泰科\)](#)