



TE Connectivity

CUSTOMER DATA

PART NO.

1432874-1

SHT. 1
OF 2



DRAWN N.TABAKOVIC	APPROVAL L.BENNETT	DATE FIRST_DRAWN 10-24-06	SCALE 1:1
----------------------	-----------------------	------------------------------	--------------

CUSTOMER
TYCO_ELECTRONICS_STANDARD

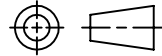
TOLERANCE	0.X	=	+/-
UNLESS	0.XX	=	+/-
SPECIFIED	0.XXX	=	+/-
OTHERWISE	ANGLES	=	+/-



DO NOT SCALE THIS DRAWING

CHANGES			
REV.	DATE	CO	APP.
	04OCT2016	ECR-16-014229	B.T.
	07NOV2017	ECO-17-003787	B.T.

NOT TO BE USED IN AUTOMOTIVE APPLICATIONS OR APPLICATIONS REQUIRING PPAP AND/OR IMDS DOCUMENTATION
ELECTRICAL CHARACTERISTICS: (ALL DATA APPLIES @ 23°C UNLESS OTHERWISE SPECIFIED)

COIL DATA:

NOMINAL VOLTAGE: 24 VDC
 OPERATE VOLTAGE: 15.6 VDC MAXIMUM
 RELEASE VOLTAGE: 2.4 VDC MINIMUM
 COIL RESISTANCE: 317.5 OHMS +/- 10%
 OPERATE TIME: 10 mSEC. MAXIMUM EXCLUDING BOUNCE
 RELEASE TIME: 13 mSEC. MAXIMUM EXCLUDING BOUNCE
 TEMPERATURE RANGE: OPERATING -40°C TO +85°C

CONTACT DATA: (CONTACT DATA IS FORMATTED N.O./N.C.)

CONTACT ARRANGEMENT: 1 FORM C (SPDT)
 CONTACT MATERIAL: AgSnO (SILVER TIN-OXIDE)
 CONTACT MILLIVOLT DROP: 200mv @ 35A ON N.O. CONTACTS (AFTER SWITCHING)
 250mv @ 20A ON N.C. CONTACTS (AFTER SWITCHING)
 MAXIMUM MAKE CURRENT: 90A/30A (LAMP) @ 16 VDC
 MAXIMUM BREAK CURRENT: 40A/30A @ 16 VDC RESISTIVE
 MAXIMUM CONTINUOUS CURRENT: 40A/30A @ 23°C , 35A/20A @ 85°C
 INITIAL BREAKDOWN CURRENT 500V RMS CONTACTS TO COIL

EXPECTED LIFE: 100,000 OPERATIONS, 40 A, 14 VDC RESISTIVE ON NORMALLY OPEN CONTACT

MECHANICAL CHARACTERISTICS:

EXPECTED LIFE: 10 MILLION OPERATIONS, NO CONTACT LOAD
 TERMINALS: COPPER, UNPLATED
 ENCLOSURE: EPOXY SEALED



TE Connectivity

CUSTOMER DATA

PART NO.

1432874-1

SHT. 2
OF 2

DRAWN
N.TABAKOVIC

APPROVAL
L.BENNETT

DATE FIRST_DRAWN
10-24-06

SCALE
1:1

CUSTOMER

TYCO_ELECTRONICS_STANDARD

TOLERANCE 0.X = +/-
 UNLESS 0.XX = +/-
 SPECIFIED 0.XXX = +/-
 OTHERWISE ANGLES = +/-

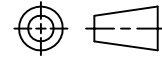

DO NOT SCALE THIS DRAWING

REV D

MILLIMETERS

MARKING TO INCLUDE:

TYCO ELECTRONICS NAME, TYCO ELECTRONICS PART NUMBER, SCHEMATIC, COIL VOLTAGE, COUNTRY OF ORIGIN, AND DATE CODE

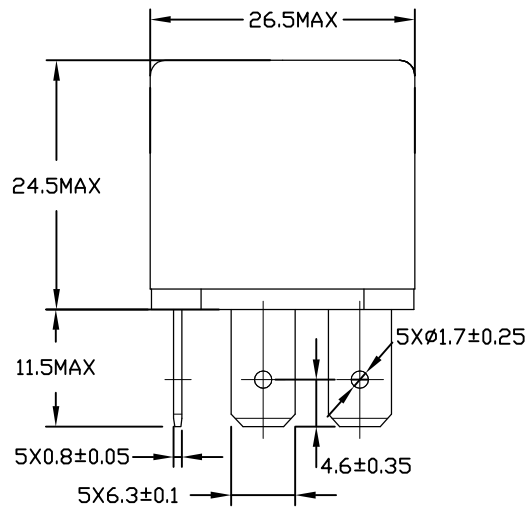

↑K

K Aspect

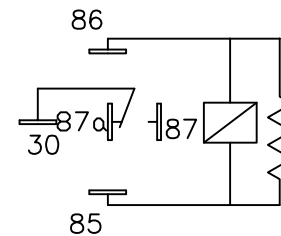
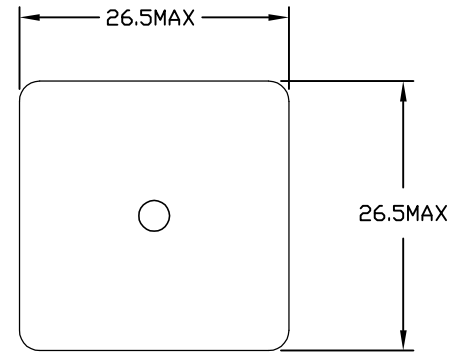
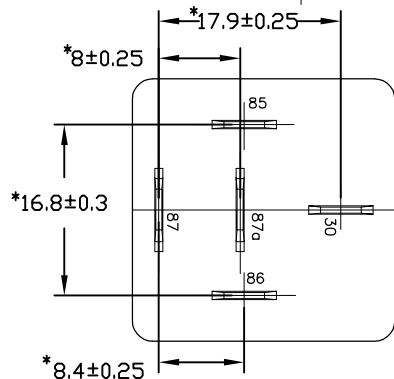

Schematic Drawing
(Bottom views)

* TERMINAL LOCATIONS APPLY AT THE BASE OF THE TERMINALS

NOT TO BE USED IN AUTOMOTIVE APPLICATIONS OR APPLICATIONS REQUIRING PPAP AND/OR IMDS DOCUMENTATION

单击下面可查看定价，库存，交付和生命周期等信息

[>>TE Connectivity\(泰科\)](#)