

THIS DRAWING IS UNPUBLISHED. RELEASED FOR PUBLICATION
 © COPYRIGHT - By TYCO ELECTRONICS CORPORATION. ALL RIGHTS RESERVED.

LOC	DIST	REVISIONS			
P	LTR	DESCRIPTION	DATE	DWN	APVD
AF	50				
	D	REVISE PER ECR-13-013738	15FEB2014	GRZ	JL

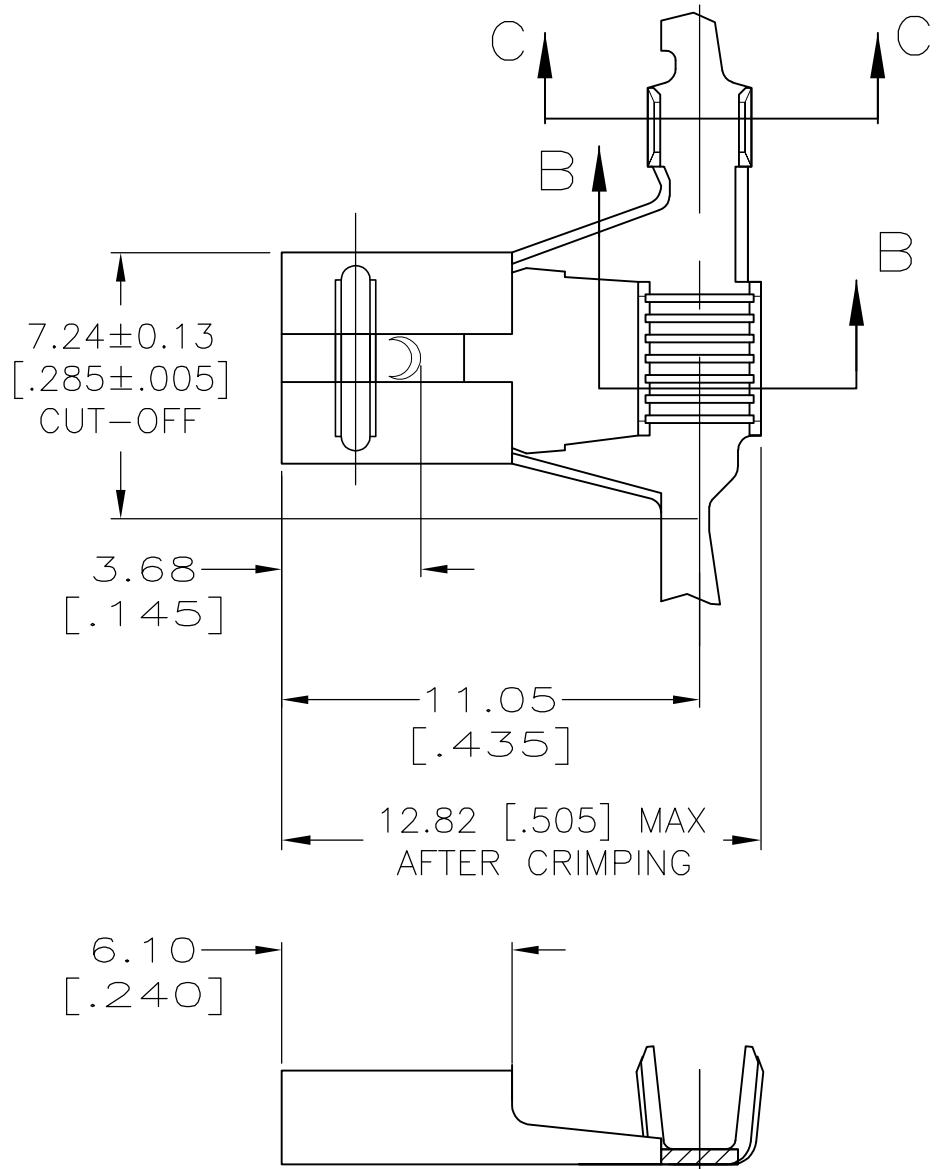

- 1 CONTINUOUS STRIP ON REELS.
- 2 ACCEPTS MAGNET WIRE RANGES 2000-4050 CMA.
- 3 MATING TAB THK TO BE 0.81±0.025 [.032±.001].
- △ 4 0.002032 [.000080] MIN TIN

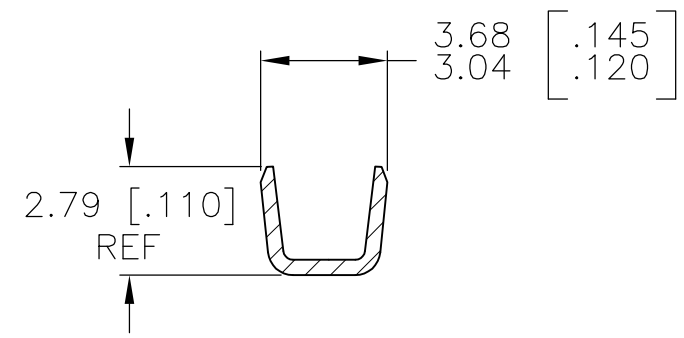
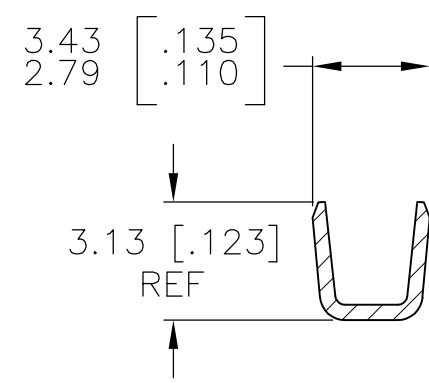
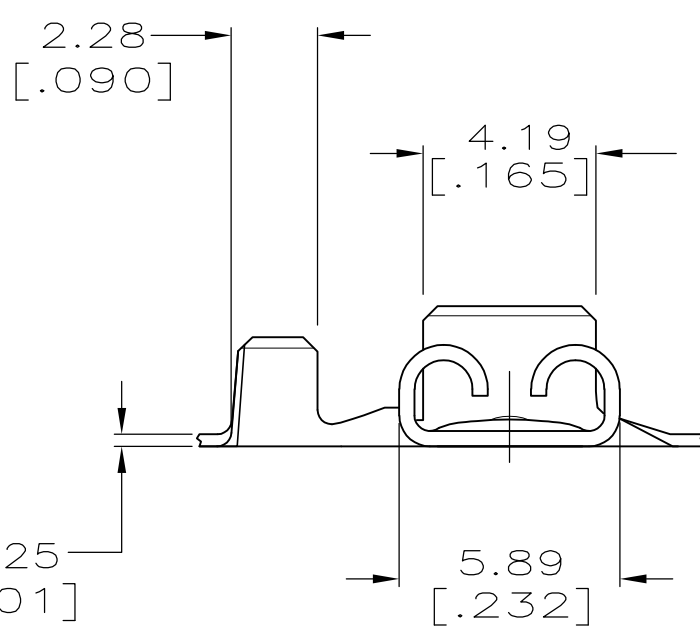

1217955-1
PART NO.

THIS DRAWING IS A CONTROLLED DOCUMENT.		DWN	JR RUTH	16MAY03	STE TE Connectivity
DIMENSIONS: mm		CHK	MS FEHER	16MAY03	
TOLERANCES UNLESS OTHERWISE SPECIFIED:		APVD	P DESANTIS	16MAY03	
0 PLC ± - 1 PLC ± - 2 PLC ± 0.25 [.010] 3 PLC ± - 4 PLC ± - ANGLES ± -		PRODUCT SPEC	NAME		
MATERIAL: BRASS		FINISH	△ 4		RECEPTACLE, FASTON, FLAG, AMPLIVAR, 4.75 [.187] SERIES
		WEIGHT	-		SIZE: A3
		CUSTOMER DRAWING		SCALE: 5:1	CAGE CODE: 00779
				DRAWING NO: C-1217955	RESTRICTED TO: -
				SHEET: 1 OF 1	REV: D

单击下面可查看定价，库存，交付和生命周期等信息

[>>TE Connectivity\(泰科\)](#)