

P	LTR	DESCRIPTION	DATE	DWN	APVD
-		SEE SHEET 1	-	-	-

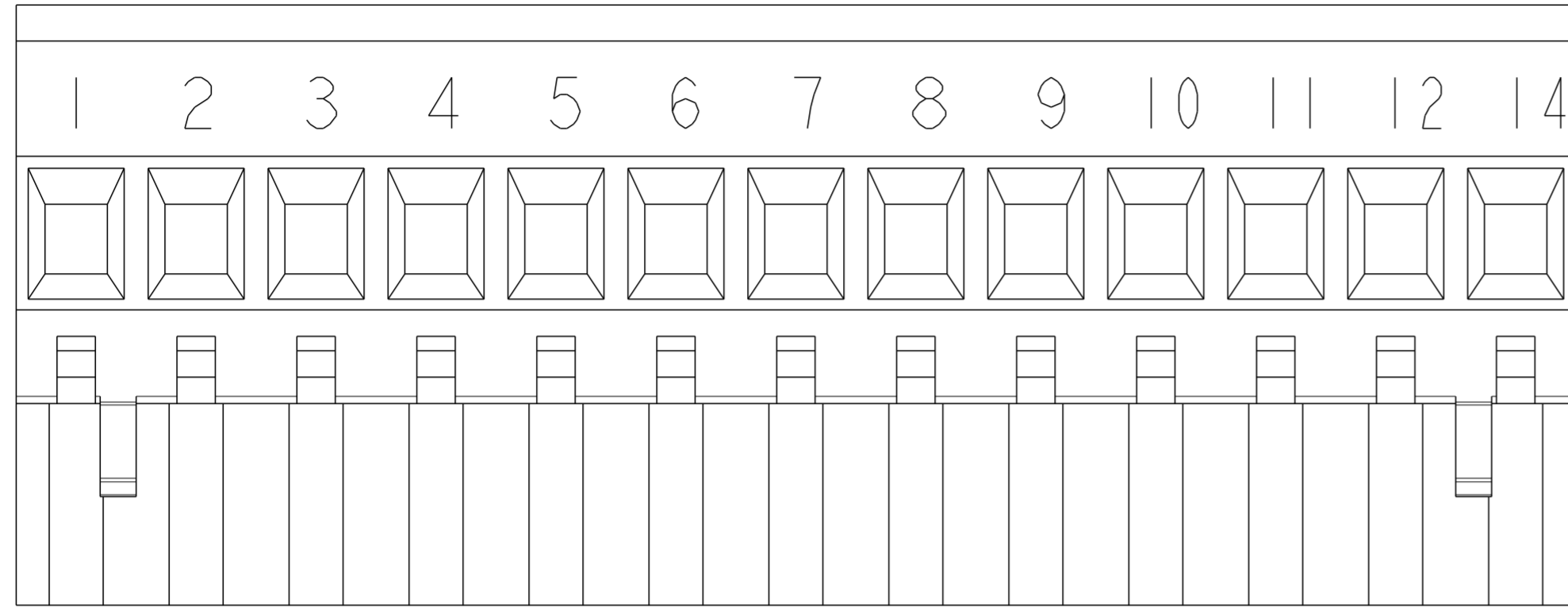

OBSOLETE ~~2-284046-7~~ AS SHOWN

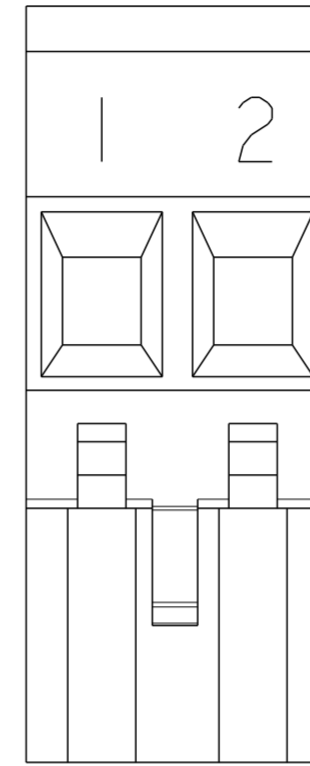

OBSOLETE ~~3-284046-0~~ AS SHOWN

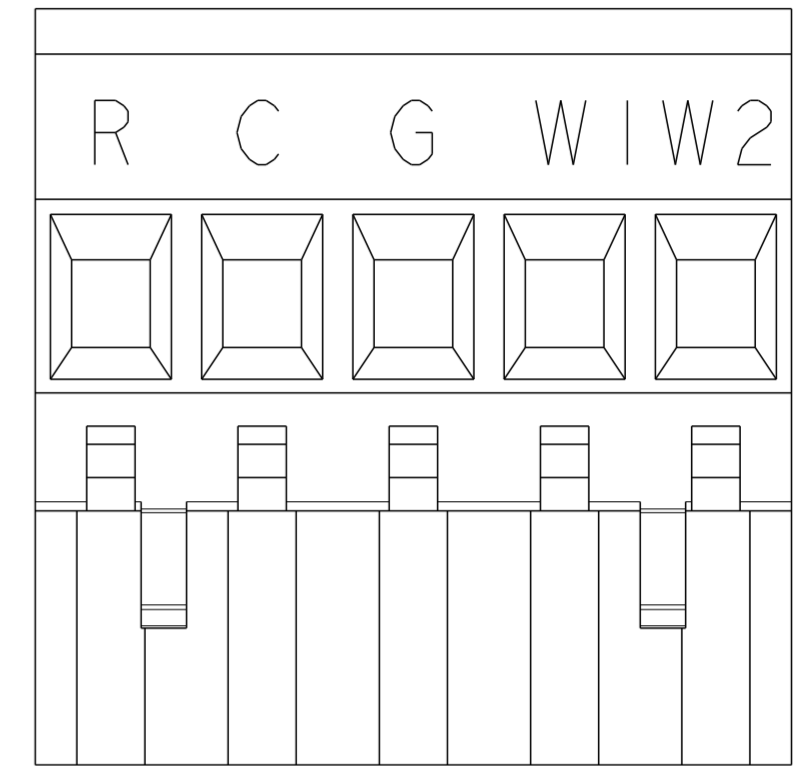

3-284046-7 AS SHOWN

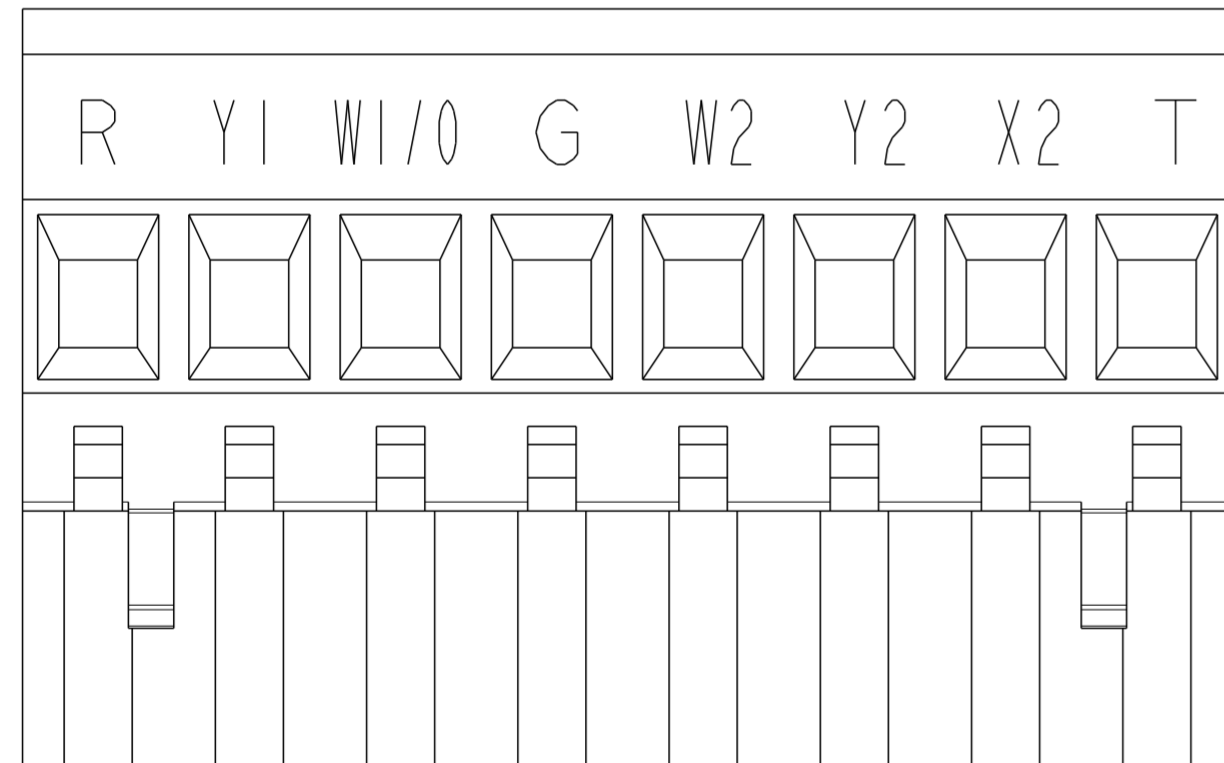

OBSOLETE ~~2-284046-6~~ AS SHOWN

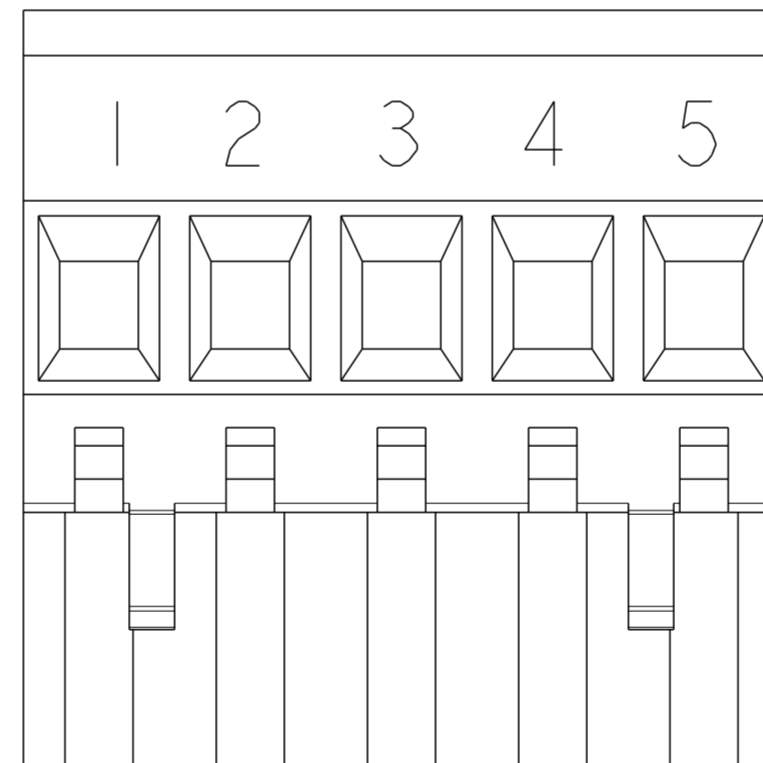

OBSOLETE ~~2-284046-9~~ AS SHOWN

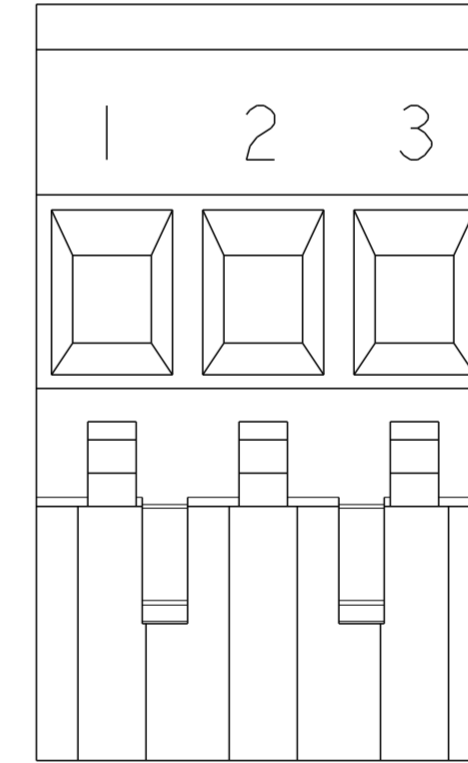

OBSOLETE ~~3-284046-1~~ AS SHOWN

THIS DRAWING IS A CONTROLLED DOCUMENT.		DWN S. WELDON 05FEB2003	 TE Connectivity
DIMENSIONS: mm		CHK C. RICHARD 05FEB2003	
TOLERANCES UNLESS OTHERWISE SPECIFIED: 0 PLC ± 1 PLC ±0.30 2 PLC ±0.25 3 PLC ± 4 PLC ± ANGLES ±2°		APVD C. RICHARD 05FEB2003	NAME TERMINAL BLOCK, VERTICAL PLUG, STACKING, RIGHT HAND, 5.00mm PITCH
MATERIAL SEE NOTES		PRODUCT SPEC -	SIZE A20779
FINISH SEE NOTES		APPLICATION SPEC -	CAGE CODE C-284046
CUSTOMER DRAWING		WEIGHT -	DRAWING NO C-284046
		RESTRICTED TO	SCALE 4:1 SHEET 2 OF 3 REV E5

REVISIONS				
P	LTR	DESCRIPTION	DATE	APVD
-		SEE SHEET 1	-	-

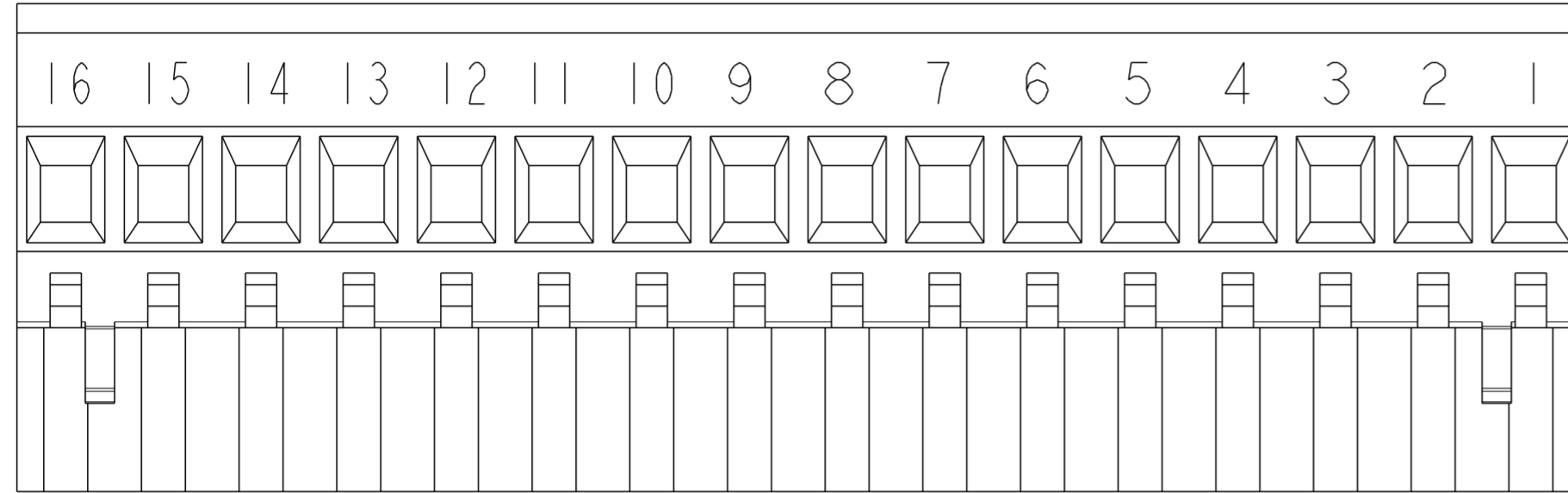

OBSOLETE ~~3-284046-2~~ AS SHOWN \triangle 6

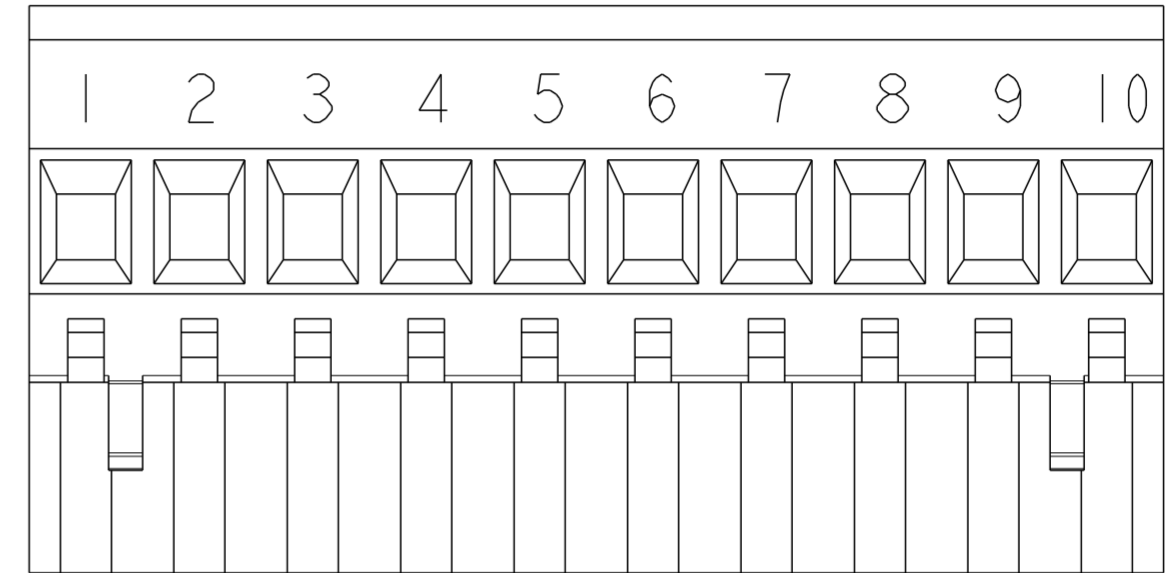

OBSOLETE ~~3-284046-4~~ AS SHOWN

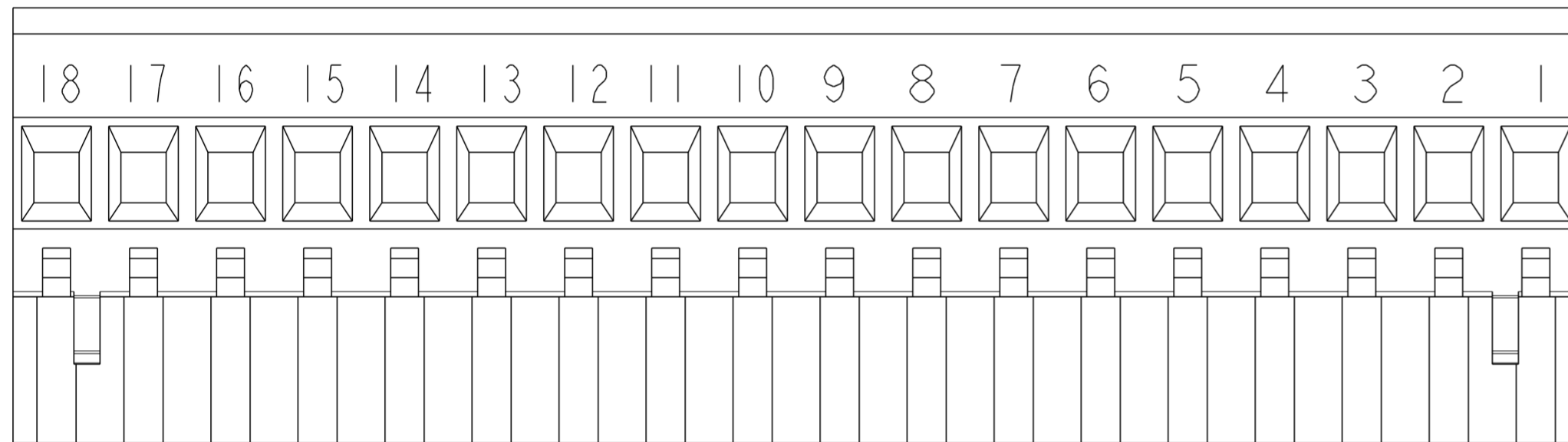

OBSOLETE ~~3-284046-3~~ AS SHOWN \triangle 6

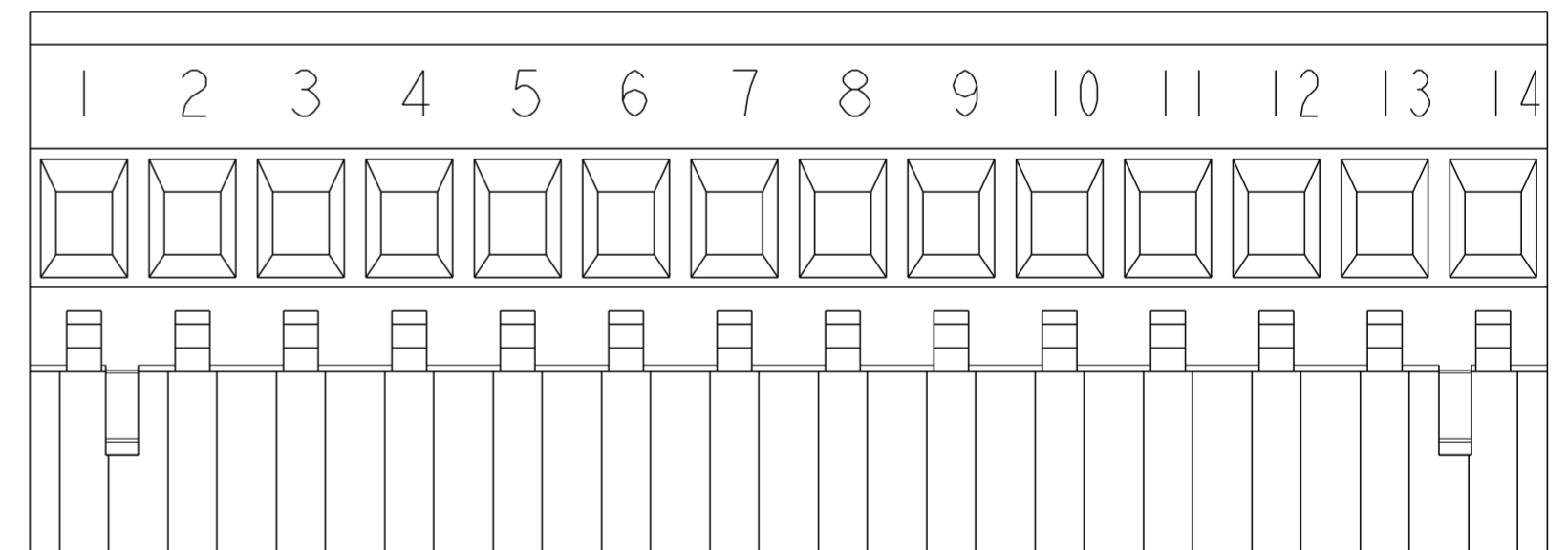

OBSOLETE ~~3-284046-5~~ AS SHOWN

THIS DRAWING IS A CONTROLLED DOCUMENT.		DWN S. WELDON 05FEB2003	 TE Connectivity	
DIMENSIONS: mm		CHK C. RICHARD 05FEB2003		
TOLERANCES UNLESS OTHERWISE SPECIFIED:		APVD C. RICHARD 05FEB2003	NAME TERMINAL BLOCK, VERTICAL PLUG, STACKING, RIGHT HAND, 5.00mm PITCH	
0 PLC ± 1 PLC ±0.30 2 PLC ±0.25 3 PLC ± 4 PLC ± ANGLES ±2° FINISH		PRODUCT SPEC -	SIZE A2	CAGE CODE p0779
MATERIAL SEE NOTES		APPLICATION SPEC -	DRAWING NO C-284046	RESTRICTED TO
WEIGHT -		CUSTOMER DRAWING		SCALE 4:1 SHEET 3 OF 3 REV E5

单击下面可查看定价，库存，交付和生命周期等信息

[>>TE Connectivity\(泰科\)](#)