

LOC	DIST	REV	PER	DESCRIPTION	DATE	BY	APP
AA	22	E	REV PER	ECO-08-026230	04SEP2008	RQ	TX
		E1	REVISED PER	ECO-09-024927	10NOV09	KK	AEG
		F	ECO-11-015766		30MAY2011	EL	LR

MECHANICAL:

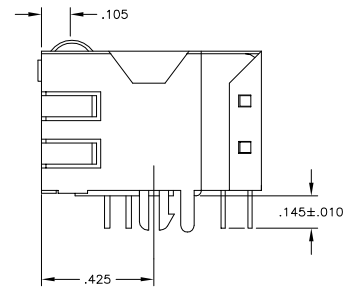
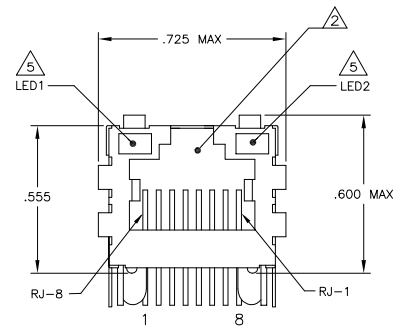
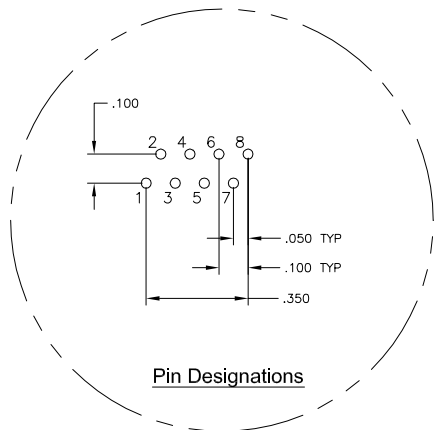
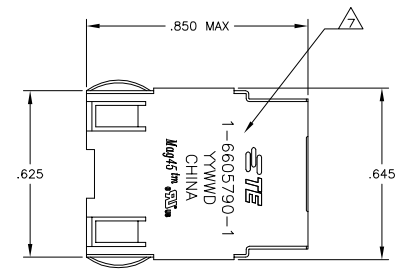

- MATERIALS:**
- HOUSING - THERMOPLASTIC PET POLYESTER FLAMMABILITY RATING UL 94V-0.
 - SHIELD - .010" THICK, C26800 BRASS PREPLATED WITH 30μINCH MIN SEMI-BRIGHT NICKEL, SOLDER TABS POST DIPPED WITH 100μINCH MIN SAC SOLDER.
 - MOD JACK CONTACTS - 0.0157" x 0.018" PHOSPHOR BRONZE, 50μINCH MIN OVERALL NICKEL UNDERPLATE, WITH SELECT 50μINCH MIN HARD GOLD FINISH PLATE.
 - SOLDERTAILS WITH 100μINCH MIN MATTE TIN AND/OR SAC SOLDER DIP.
 - LIGHT EMITTING DIODE(LED) - DIFFUSED EPOXY LENS, .020" x .020" CARBON STEEL WIREFRAME LEADS PRE-PLATED WITH 80μINCH SILVER OVER 40μINCH NICKEL UNDERPLATE OVER 40μINCH COPPER UNDERPLATE, POST-PLATED WITH 100μINCH MIN MATTE TIN AND/OR SAC SOLDER DIP OR PURE TIN SOLDER DIP.

RJ45 JACK CAVITY CONFORMS TO FCC RULES AND REGULATIONS PART 68, SUB PART F.

- MAGNETICS**
- IMPEDANCE: 100 OHMS
 - TURNS RATIO (CHIP-CABLE): TX = 1:1, RX = 1:1
 - OPEN CIRCUIT INDUCTANCE (OCL): 350μH MIN @100kHz, 0.1VRMS, 8mA DC BIAS FROM 0°C TO 70°C, TX AND RX
 - PERFORMANCE @ 25°C:
 - INSERTION LOSS (IL): 1.1dB MAX FROM 0.5MHz TO 100MHz
 - RETURN LOSS (RL): 18dB MIN FROM 0.5MHz TO 30MHz
 - 18-20LOG(f/30)dB MIN FROM 30.1MHz TO 60MHz
 - 12dB MIN FROM 60.1MHz TO 80MHz
 - CROSSTALK ATTENUATION: 35dB MIN FROM 0.5MHz TO 40MHz
 - 33-20*LOG(f/50)dB MIN FROM 40.1MHz TO 100MHz
 - COMMON MODE REJECTION RATIO (CMRR): 30dB MIN FROM 0.5MHz TO 100MHz
 - ISOLATION VOLTAGE: 2250VDC (MAX) FOR 60 SECONDS WITH A RISE TIME OF 500V/SEC.

4. OPERATING TEMPERATURE: FROM 0°C - +70°C.

- LED WITH 250 OHM RESISTORS LED IS DRIVEN WITH 5V VOLTAGE AND THE MAX OPERATING CURRENT IS 20mA.**
- LED COLOR - DOMINANT WAVELENGTH (AD): GREEN 568 nm TYP @ VF=5V
 - FORWARD CURRENT (IF): GREEN 12 mA TYP @ VF=5V
 - DOMINANT WAVELENGTH (AD): YELLOW 588 nm TYP @ VF=5V
 - FORWARD CURRENT (IF): YELLOW 13 mA TYP @ VF=5V

INDICATED CONNECTIONS ARE FOR HUB CONFIGURATION. THE MAGNETICS ARE ASYMMETRICAL, AND ARE NOT AUTO-MDI/MDIX CAPABLE.

TE CONNECTIVITY LOGO, PART NUMBER, DATE CODE, COUNTRY OF ORIGIN AND AGENCY APPROVAL MARKING IN APPROXIMATE LOCATION SHOWN.

8. THESE PARTS ARE RECOMMENDED FOR WAVE SOLDERING PROCESS, PREHEAT TEMPERATURE IS 120°C TO 160°C, 120 SECONDS TO 180 SECONDS, PEAK SOLDERING TEMPERATURE IS 260 °C MAX, 10 SECONDS MAX.

OBsolete PARTS: OBSOLETE CIS STREAMLINING PER D.RENAUD/D.SINISI

757 SERIES MAGNETIC CIRCUIT

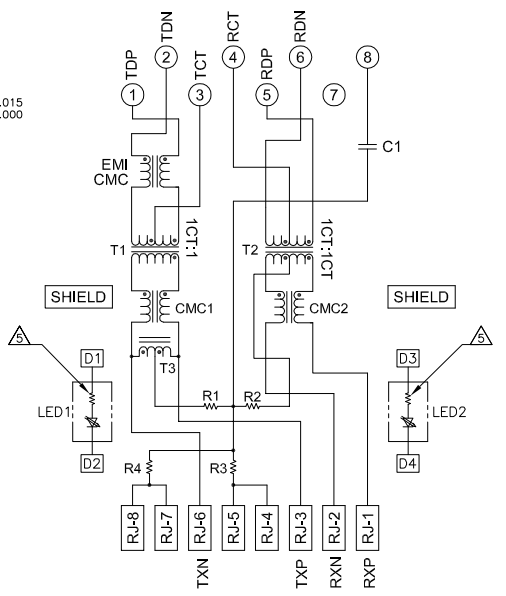

C1=1000pF, 2kV CAPACITOR
R1-R4 = 75 OHMS, 1/16 W RESISTORS

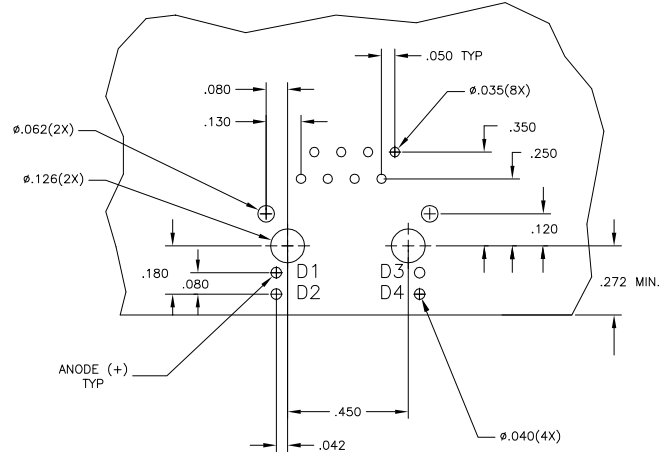

Suggested PCB Layout (Component Side)

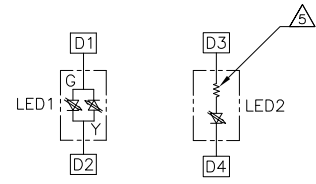

LED Configuration FOR 5-6605790-4 ONLY

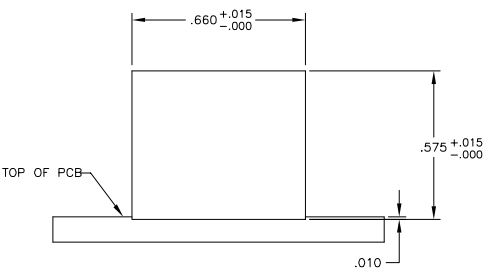

Suggested Panel Cutout

OBsolete	YES	GREEN/YELLOW	GREEN	5-6605790-4
	YES	YELLOW	GREEN	5-6605790-2
	YES	GREEN	YELLOW	5-6605790-1
OBsolete	NO	GREEN	GREEN	1-6605790-1

THIS DRAWING IS A CONTROLLED DOCUMENT.		REV. 1 - VARELA - 02MAR2008		REV. 2 - FAROLE - 02MAR2008	
DIMENSIONS:	INCHES	NO. PARTS:	1	DATE:	108-2100
		REVISED:	2	SCALE:	AS SHOWN
		APPROVED:	4	SIZE:	A1
		FINISH:	1	WEIGHT:	0.0779g
				CAGE CODE:	6605790
				DRAWING NO:	108-2100
				RESTRICTED TO:	NTS
				SHEET:	1 of 1
				REV:	F

单击下面可查看定价，库存，交付和生命周期等信息

[>>TE Connectivity\(泰科\)](#)