

**AMPMODU 2mm RECEPTACLE, Wire to Board, Crimp terminals****1. SCOPE**

This specification covers the requirements for crimping of 2.0mm pitch Wire to Board, crimp terminals of AMPMODU 2mm RECEPTACLE PLATFORM. These requirements are applicable to specific tools. For specific wire and products covered in this specification refer to the appropriate AMPMODU Customer drawing.

2. REFERENCE DOCUMENTS

114-57013 - AMP 2.0mm PITCH EMIX Economic Metric Interconnect Series, Wire-To-Board System

114-18022 - GENERAL CRIMP SPEC.

114-18022-10 - Making and Evaluation of Cross Sections for F-Crimp terminations

408-7424 - Checking the Terminal Crimp Height or Gaging the Die Closure

108-64040-1 - Product Specification, AMPMODU 2mm RECEPTACLE, Wire to Board

408-9453 - Extraction Tool Instruction Sheet

3. APPLICABLE PRODUCT

- Table 3.1

	AWG 28-24 (0.08- 0.22 sq.mm) Insulation - Max Dia 1.0mm	AWG 28-30 (0.05-0.08 sq.mm) Insulation - Dia 0.5 - 1.0 max		
Contact area Plating	Crimp Terminal PN	Applicator part number	Crimp Terminal PN	Applicator part number
Tin	2-2316113-2	Ocean applicator - Upon request	2-2316114-2	Ocean applicator - Upon request
Au 0.1µm	3-2316113-3		3-2316114-3	
Au 0.38 µm	4-2316113-4		4-2316114-4	
Au 0.76 µm	5-2316113-5		5-2316114-5	
Tin	2-2316113-3	Hand tool – Loose piece PN 2326267-1	2-2316114-3	Hand tool – Loose piece PN 2326270-1
Au 0.1µm	3-2316113-4		3-2316114-4	
Au 0.38 µm	4-2316113-5		4-2316114-5	
Au 0.76 µm	5-2316113-6		5-2316114-6	

- Extraction Tool
 - Part Number: 843477-3

3.1. Product Image

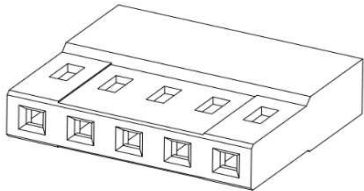
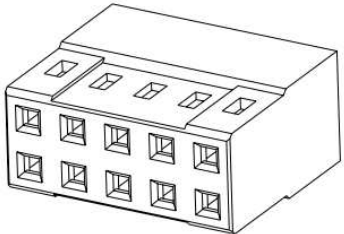
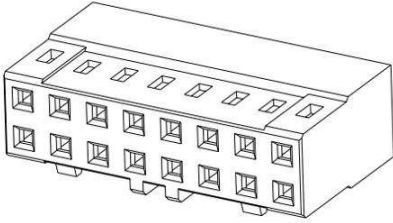
CtB Housing	 <p>Single Row, Plain - 2316102</p>	 <p>Dual Row, Plain – 2316108</p>	 <p>Dual row, Locking ramp - 2316109</p>
-------------	---	--	--

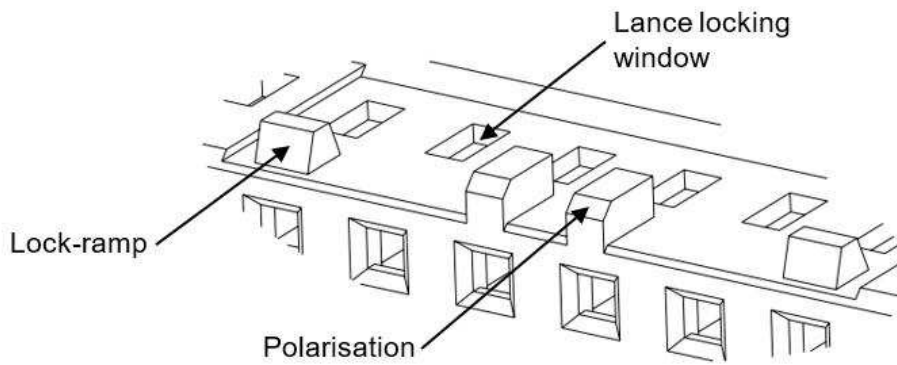

Housing – with Locking ramp

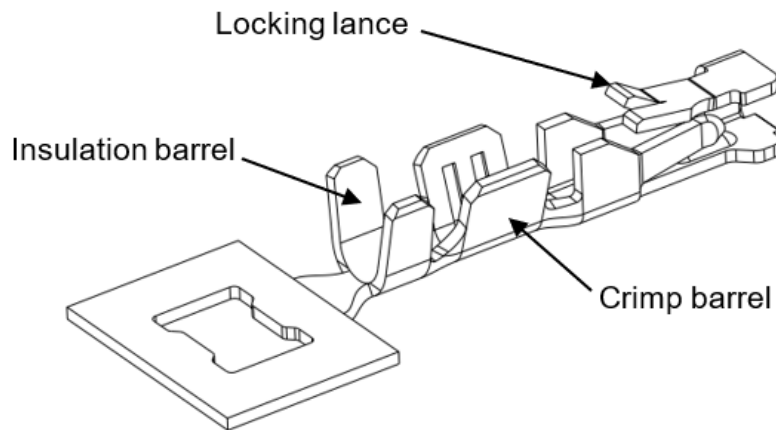

Crimp Contact

4. DEFINITIONS

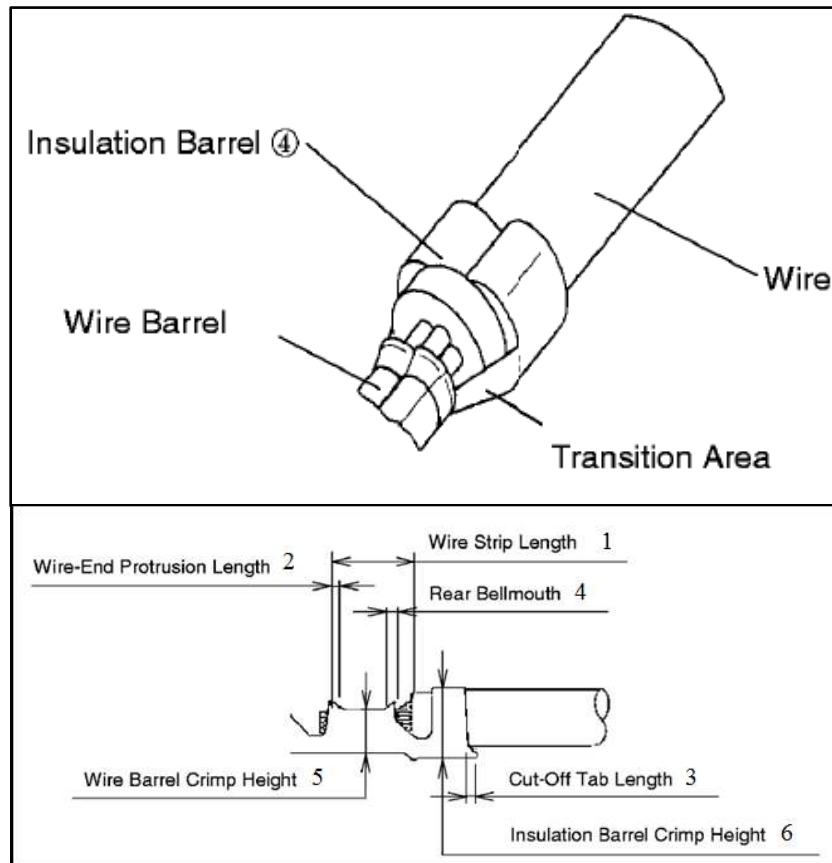

5. CRIMPING REQUIREMENT

Table 5.1

Item	Check Items	Crimping requirements
1	Wire strip length	1.5 - 2.0 mm
2	Wire end protrusion length	0.1 - 0.4 mm
3	Cut-off Tab length	0.0 - 0.2 mm
4	Rear bell mouth	0.2- 0.4mm
5	Wire barrel crimped dimensions	Refer table 6.1
6	Insulation barrel crimped dimensions	Refer table 6.1

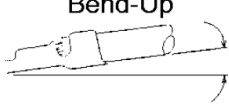
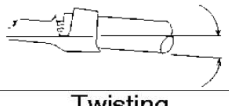
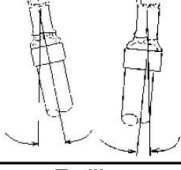
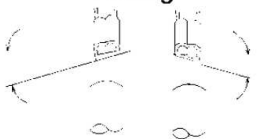
Allowable Deviation after Crimping	Bend-Up 	6° Max.	6° Max.
	Bend-Down 	6° Max.	6° Max.
	Twisting 	5° Max.	5° Max.
	Rolling 	7° Max.	7° Max.

6. CRIMPING DATA

Number of wire per terminal is 1 only.

Insulation strip length: 2.75+/-0.25mm

Table 6.1:

Wire size (sq. mm)	Insulation diameter (mm)	Wire barrel		Insulation barrel
		Crimp width	Crimp height ± 0.05mm	Crimp width
24	MAX DIA 1.0mm	1.07 mm (.042 F)	0.74	1.40mm (.055 F)
26		1.07 mm (.042 F)	0.69	1.40mm (.055 F)
28		1.07 mm (.042 F)	0.64	1.40mm (.055 F)
28	0.5 – 1.0mm MAX	0.84 mm (.033 F)	0.55	1.27 mm (.033 F)
30		0.84 mm (.033 F)	0.53	1.27 mm (.033 F)

Table 6.2.

Wire Size	Current (A)	Retention force
AWG #24	2.0	29.4MIN.
AWG #26	1.5	19.6MIN
AWG #28	1.0	9.8MIN.
AWG #30	0.5	4.9MIN

Insulation O.D. 1.0mm diameter max.

Note:

- A. Tool mark is allowable at crimped areas and transition areas only
- B. The dimensions of crimp width of wire barrel and insulation barrel are the dimensions of crimping tool.

7. VISUAL AID

The illustration below shows a typical application of this product. This illustration should be used by production personnel to ensure a correctly applied product. Applications which DO NOT appear correct should be inspected using the information in the preceding pages of this specification and in the instructional material shipped with the product. Extraction tools are designed to disengage contact lance from the locking lance cavity. The lance release tip depresses the contact locking lance to allow extraction of the contact.

Figure 7

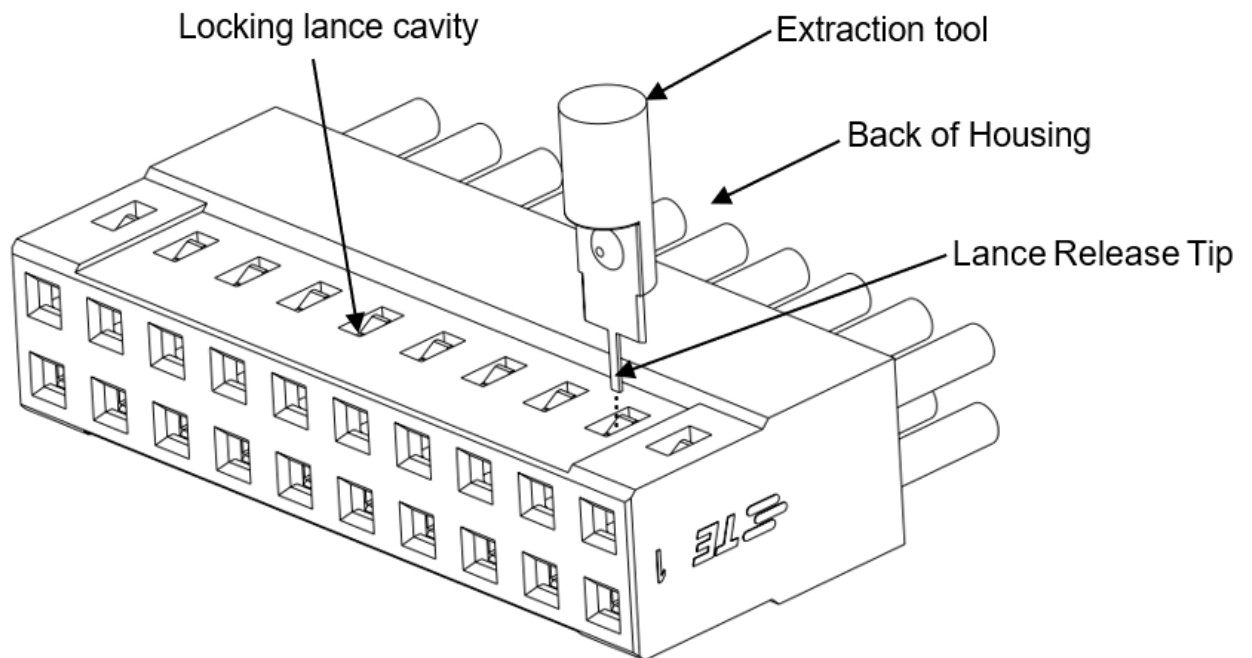

单击下面可查看定价，库存，交付和生命周期等信息

[>>TE Connectivity\(泰科\)](#)