

THIS DRAWING IS UNPUBLISHED. RELEASED FOR PUBLICATION  
 © COPYRIGHT BY TYCO ELECTRONICS CORPORATION. ALL RIGHTS RESERVED.

LOC	DIST	REVISIONS			
P	LTR	DESCRIPTION	DATE	DWN	APVD
DF	X5				
A		REV PER ECO 05-04936	7-19-05	CT	RG

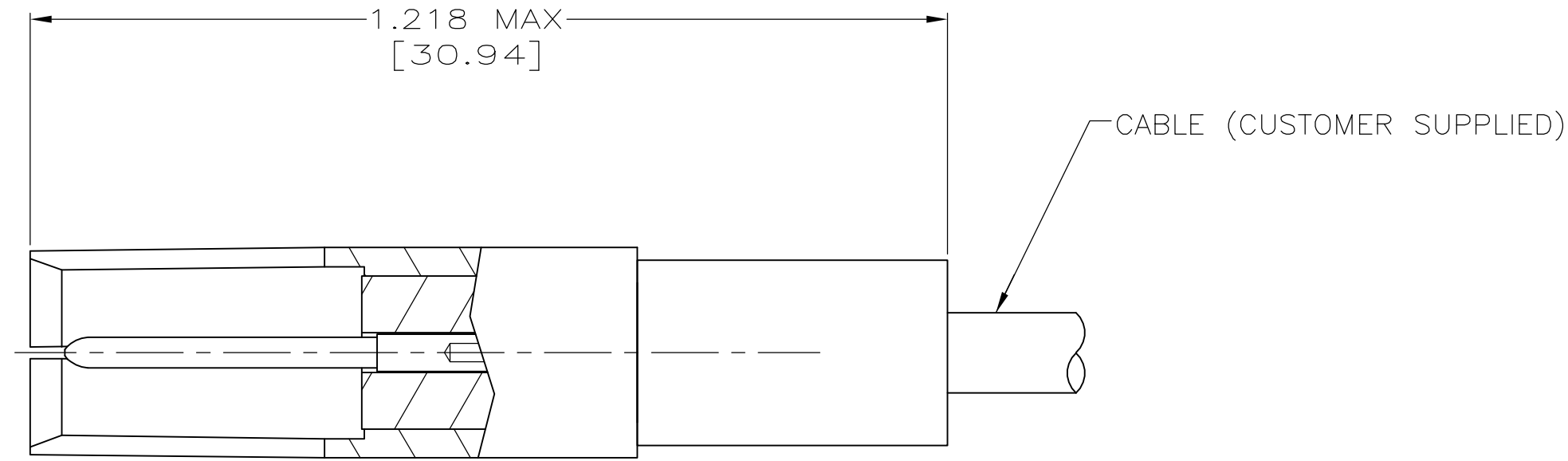

ASSEMBLED VIEW

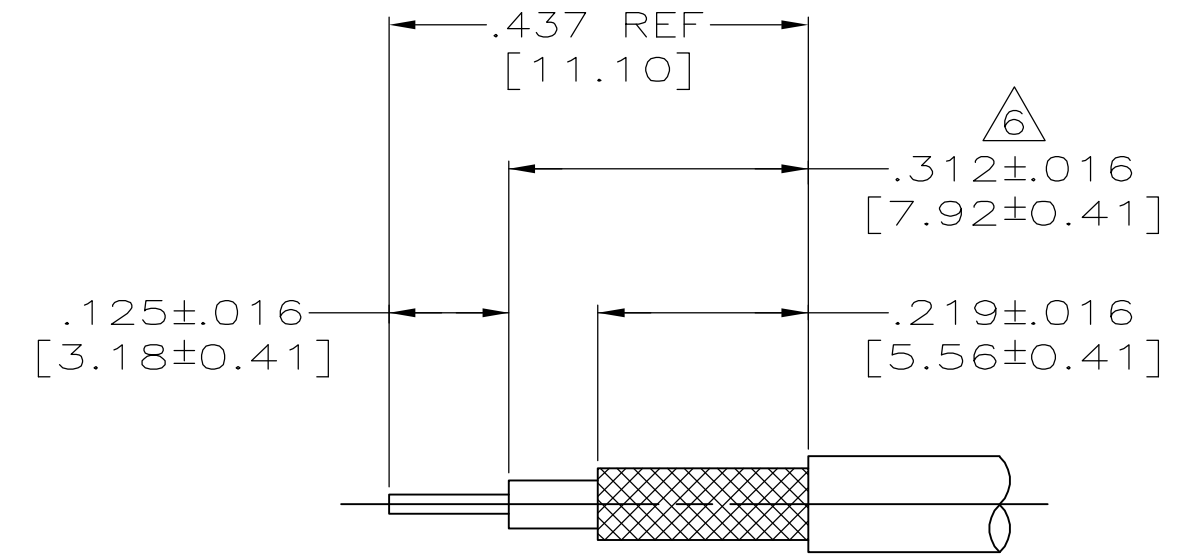

RECOMMENDED STRIP LENGTH  
SCALE: N.T.S.

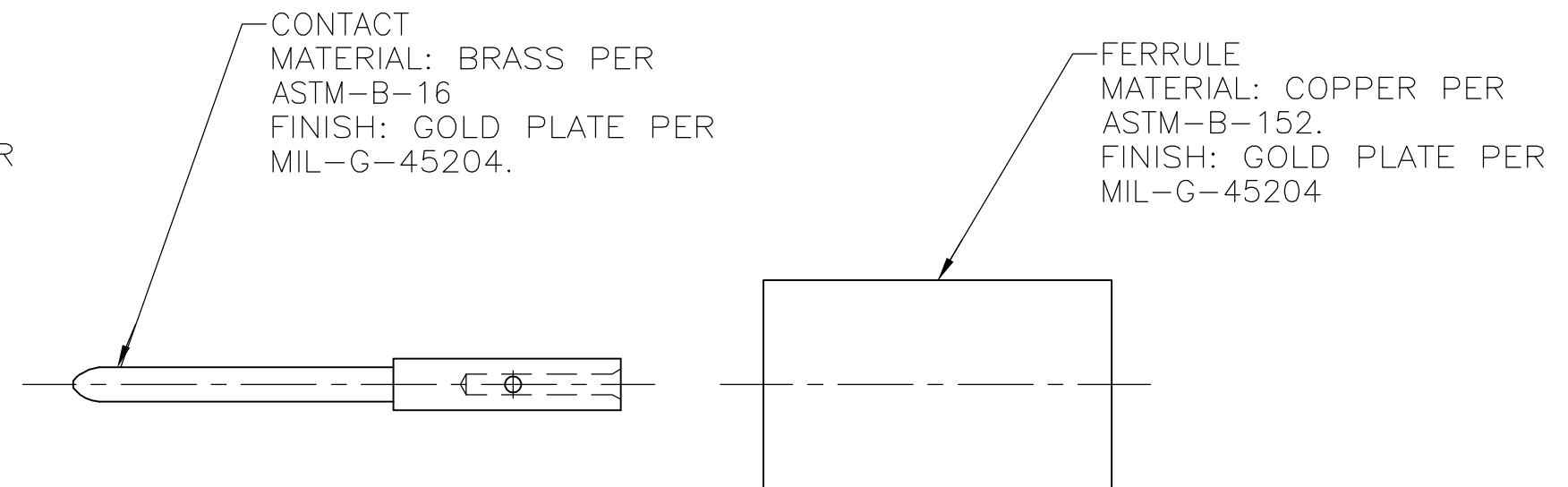
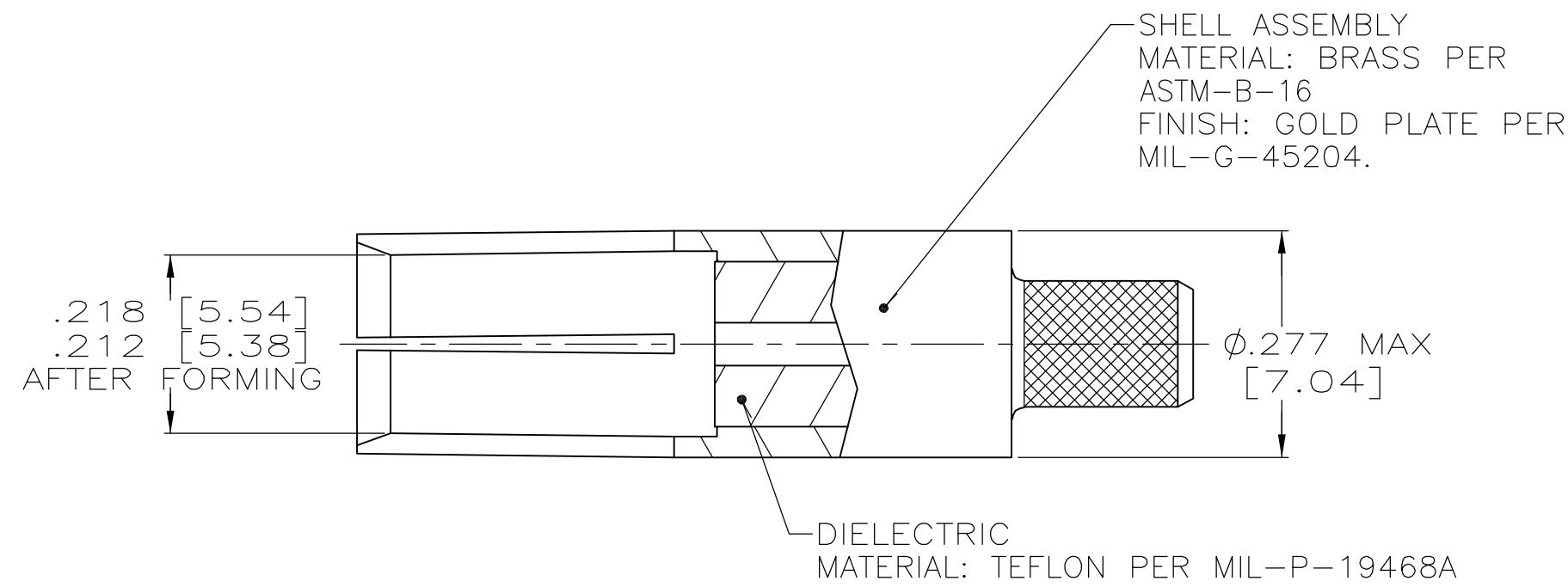

- FOR USE WITH BMS 13-65 OF CABLE.
- FERRULE CRIMPING TOOL: AMP TOOL #220066-1 CRIMP B OR #220066-2 CRIMP B.
- CONTACT CRIMPING TOOL: M22520/2-01 OR AMP TOOL NUMBER 1-601966-6, SETTING NUMBER 5. DANIELS POSITIONER PART NO. K345 OR AMP TOOL NO. 1-601966-6.
- SEE I.S. 2348.
- DANIELS MANUFACTURING CORP  
2266 FRANKLIN ROAD  
BLOOMFIELD HILLS, MI 48013

- OUTER JACKET OF CABLE MUST BE TRIMMED TO ALLOW PROPER INTER-PIN CONTACT LOCATION AFTER FERRULE CRIMP OPERATION.
- PIN AND FERRULE SHIPPED UNASSEMBLED AND CABLE IS SUPPLIED BY CUSTOMER.

1757892-1  
PART NO.

THIS DRAWING IS A CONTROLLED DOCUMENT.		DWN C.C.THOMAS 22JUN05	AMP Tyco Electronics Corporation Harrisburg, Pa 17105-3608	
DIMENSIONS: INCHES [mm]	TOLERANCES UNLESS OTHERWISE SPECIFIED:	CHK R.GROSS 6-23-05	NAME CONNECTOR, COAXIAL, RF, SOCKET SIZE 5, ARINC	RESTRICTED TO
	0 PLC ± - 1 PLC ± - 2 PLC ± - 3 PLC ± - 4 PLC ± - ANGLES ± -	APVD R.GROSS 6-23-05	SIZE A2	CAGE CODE 00779
MATERIAL SEE CALLOUTS	FINISH SEE CALLOUTS	PRODUCT SPEC APPLICATION SPEC	DRAWING NO 1757892	SCALE 5:1
		WEIGHT -	SHEET 1 OF 1	REV A
		CUSTOMER DRAWING		

1757892

单击下面可查看定价，库存，交付和生命周期等信息

[>>TE Connectivity\(泰科\)](#)