

LOC	DIST	P	F	ZONE	LTR	DESCRIPTION	DATE	APPD
CH	11				D	ECN 95032201	03-22-95	CMS
					D1	REVISED PER ECO-09-024717	04NOV09	AEG

1. RETROFIT CONTACT FOR METRIMATE AND AMPLIMITE POWER CONTACT.
  2. WIRE BARREL WILL ACCEPT #12-14 AWG WIRE.
  3. MATES WITH AMP P/N 193534.
- △ 4. OBSOLETE PARTS: OBSOLETE CIS STREAMLINING PER D.RENAUD/D.SINISI

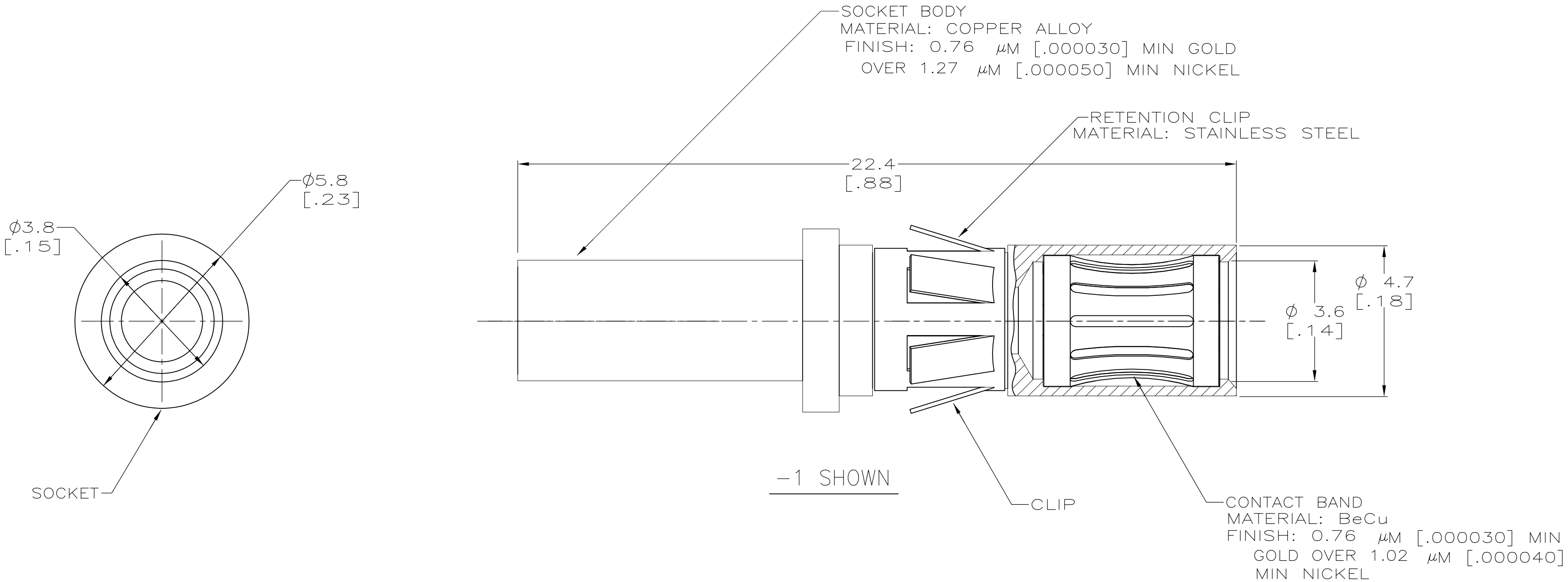

△ OBSOLETE	WITHOUT RET. CLIP	193535-2
	WITH RET. CLIP	193535-1

DO NOT SCALE PRINT. UNLESS SPECIFIED DIMENSIONS IN mm [INCHES] TOLERANCES ON :		DR D. BABOW 06-23-92		AMP Incorporated Harrisburg, PA 17105-3608	
2 PLC DEC ± -		CHK S. SIEGRIST 07-07-92			
3 PLC DEC ± -		APPD D. PETRIE 07-09-92		NAME	
ANGLES ± -		APPD P. GLASER 07-09-92		SKT ASSY, POWER, 12-14 AWG	
MATERIAL		PRODUCT SPEC		SIZE	
FINISH		APPLICATION SPEC		CAGE CODE	
-		-		DRAWING NO	
-		-		C-193535	
WEIGHT		SCALE 10:1		SHEET 1 OF 1	

THIS DRAWING IS A CONTROLLED DOCUMENT FOR AMP INCORPORATED. IT IS SUBJECT TO CHANGE AND THE CONTROLLING ENGINEERING ORGANIZATION SHOULD BE CONTACTED FOR THE LATEST REVISION.

单击下面可查看定价，库存，交付和生命周期等信息

[>>TE Connectivity\(泰科\)](#)