

4

3

2

1

THIS DRAWING IS UNPUBLISHED. RELEASED FOR PUBLICATION
© COPYRIGHT BY TYCO ELECTRONICS CORPORATION, ALL RIGHTS RESERVED.

LOC	DIST	REVISIONS					
		P	LTR	DESCRIPTION	DATE	DWN	APVD
DS	-		A1	REVISED (ECR-11-005815)	22.MAR.'11	KT	HG

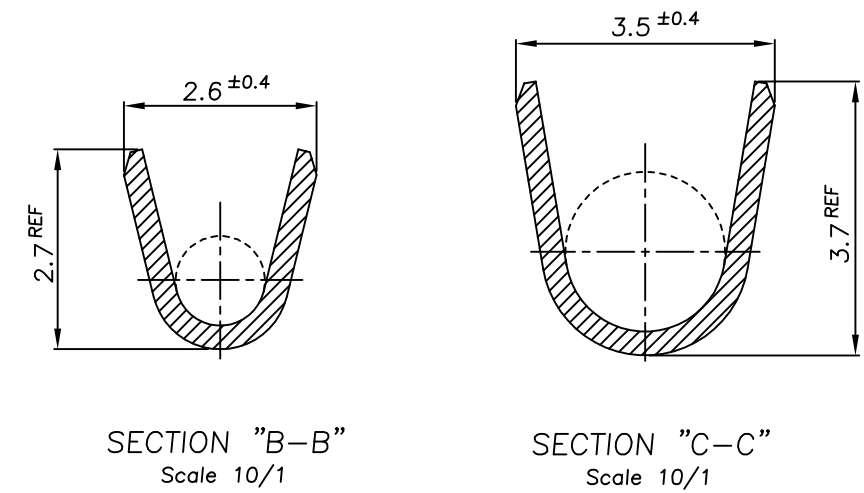
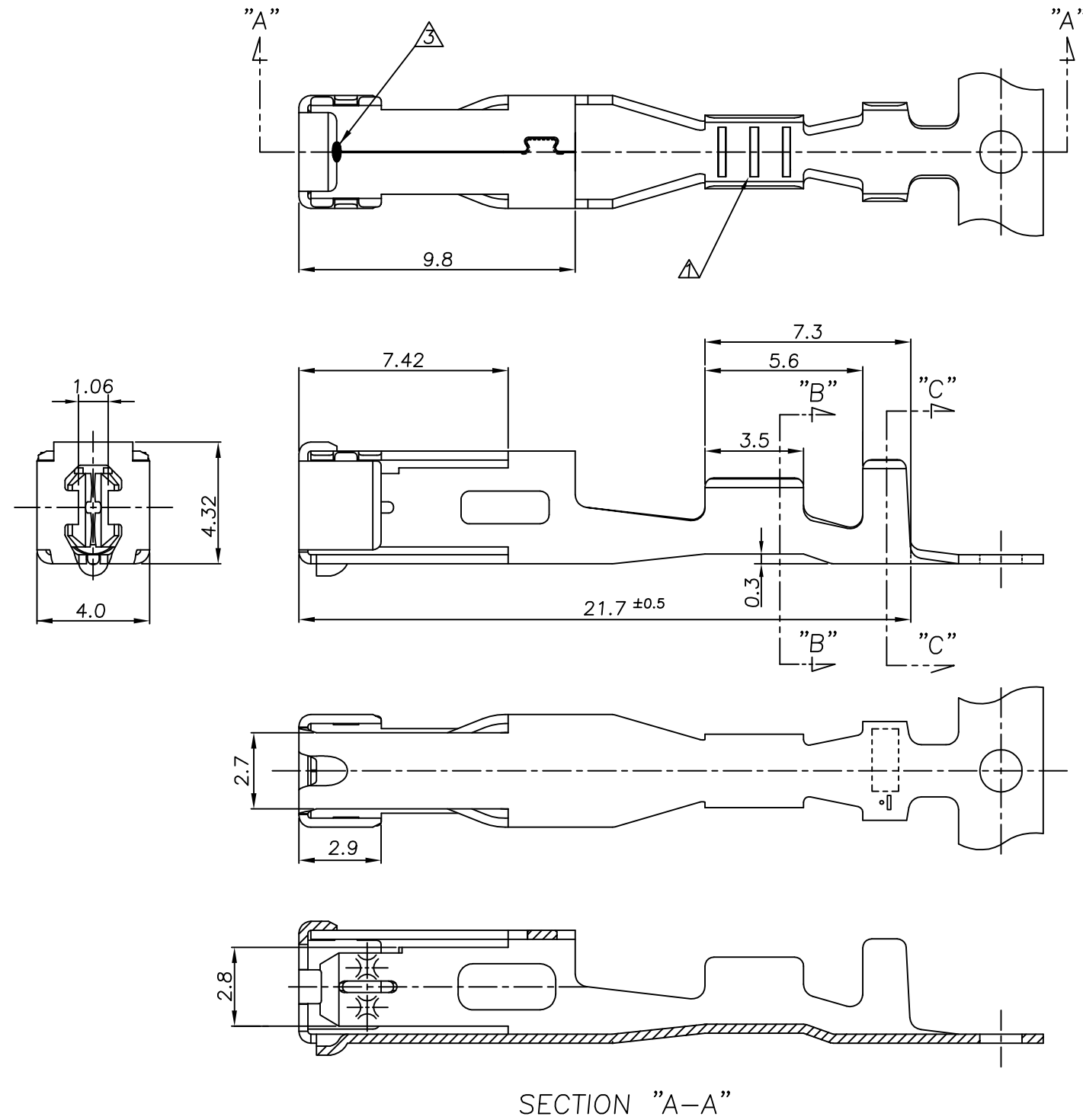

NOTE;
 ▲ THREE SERRATIONS CENTERED IN WIRE BARREL.
 2 WIRE SIZE EQUIV 0.3 ~ 0.85SQ.
 APPLICATION SPEC: 114-61033
 △ WELDING POINT

THIS DRAWING IS A CONTROLLED DOCUMENT FOR TYCO ELECTRONICS CORPORATION IT IS SUBJECT TO CHANGE AND THE CONTROLLING ENGINEERING ORGANIZATION SHOULD BE CONTACTED FOR THE LATEST REVISION.

DIMENSIONS: MM	TOLERANCES UNLESS OTHERWISE SPECIFIED: 0 <XX<10 ± 0.25 10<XX<30 ± 0.3 ANGLES ± 3°
MATERIAL SEE TABLE	FINISH SEE TABLE

PRE-TINNED	CuNiSi Alloy 0.32THK.	1743162-1
FINISH	MATERIAL	PART NO
DWN KT JUNG CHK KT LIM	TE Connectivity	
APVD HG CHD		
PRODUCT SPEC	NAME 2.8mm MCP-E NON SEALED RECP CONTACT (S)	
APPLICATION SPEC 114-61033	SIZE	DRAWING NO
WEIGHT	A3 00779	C-1743162
CUSTOMER DRAWING	SCALE 5/1	SHEET 1 OF 1 REV A1

单击下面可查看定价，库存，交付和生命周期等信息

[>>TE Connectivity\(泰科\)](#)