

P	LTR	DESCRIPTION	DATE	DWN	APVD
	B	REVISED	05JUNE2013	IC.K	JH.K
	C	REVISED	10JUNE2013	IC.K	JH.K
	C1	REVISED	25FEB2014	IC.K	JH.K
	C2	REVISED	06FEB2015	IC.K	JH.K

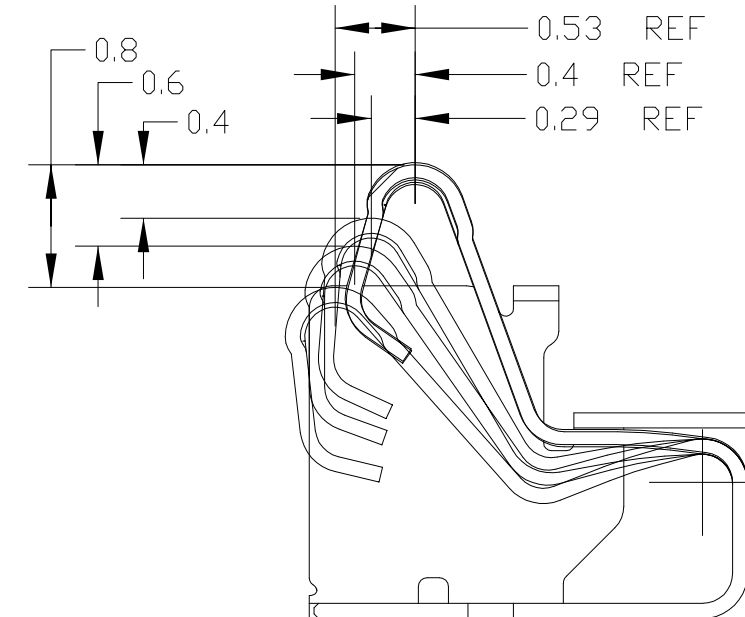

SECTION B-B
STROKE CONDITION(REFERENCE)

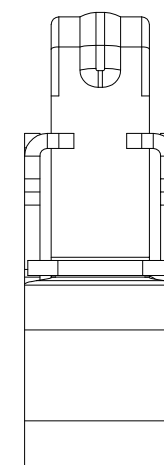
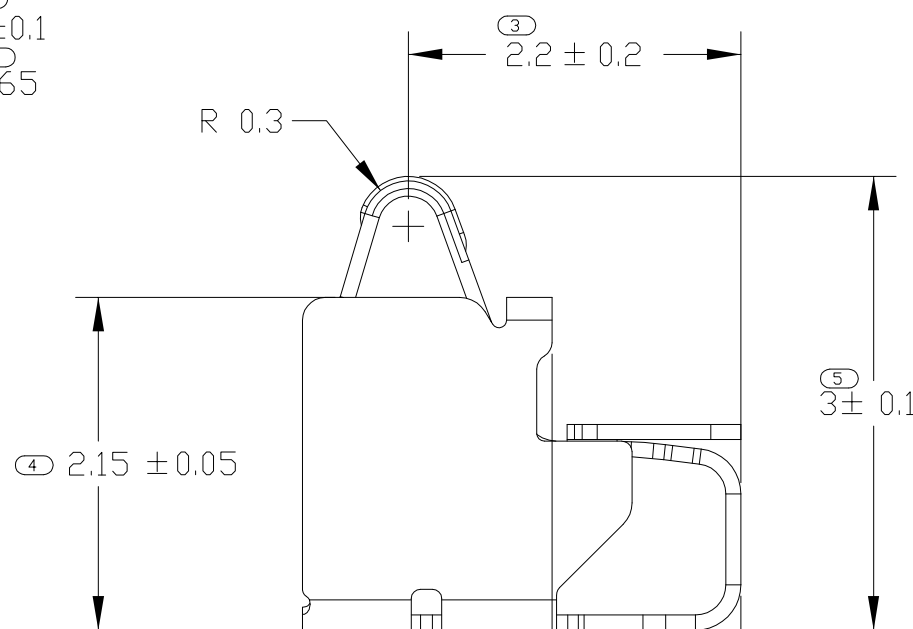
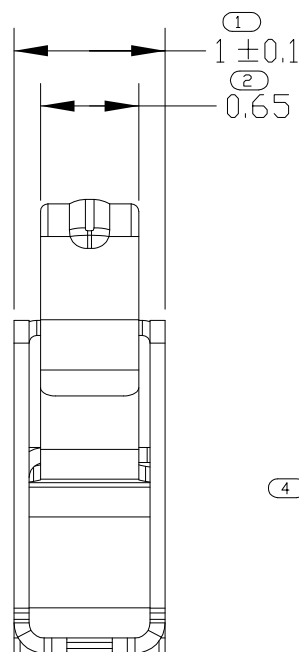
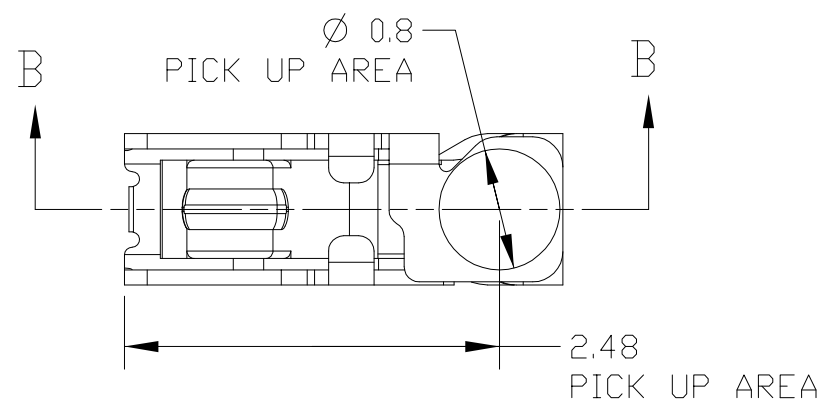
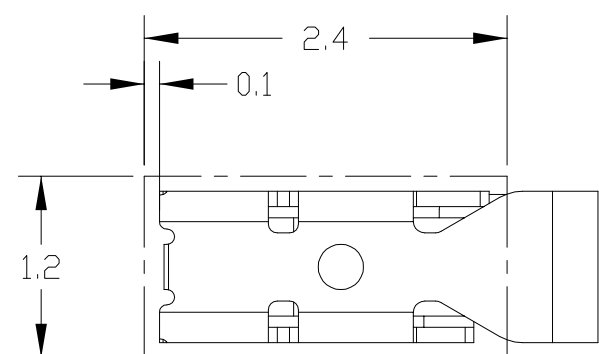

RECOMMENDED PCB LAYOUT
(REFERENCE)

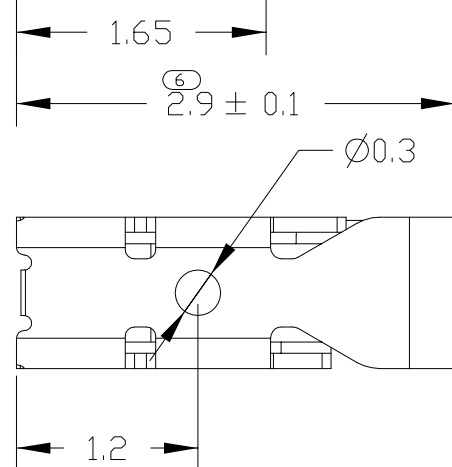

- 1 MATERIAL: TICU(COPPER ALLOY), THK.= 0.1
- 2 FINISH: Ni UNDER PLATING ALL OVER 0.8~3.0um
CONTACT PLATING: Au 0.1~0.4um
SOLDER PLATING: Au 0.05~0.35um
- 3 CUTTING BURR: 0.05mm MAX.
- 4 F/G SHOULD BE SEPARATED BASED ON THE CUSTOMER'S PART NUMBER AS BELOW TABLE

NO	PART NUMBER	CUSTOMER PART NUMBER	PRODUCT SPEC
1	2108609-5	MBV62562101	108-61190
2	2108609-6	EAG63651901	
3	2-2108609-6	-	108-61255

THIS DRAWING IS A CONTROLLED DOCUMENT.	
DIMENSIONS: mm	TOLERANCES UNLESS OTHERWISE SPECIFIED: ± 0.15
	0-PLC ±
	1-PLC ±0.5
	2-PLC ±0.13
	3-PLC ±0.013
	4-PLC ±0.0001
	ANGLES ±
MATERIAL 1	FINISH 2

DWN IC KANG	09APR2013
CHK JH KIM	09APR2013
APVD JH KIM	09APR2013
PRODUCT SPEC	SEE TABLE 4
APPLICATION SPEC	-
WEIGHT	-
CUSTOMER DRAWING	

		TE Connectivity			
		NAME			
SPRING FINGER 3.0H		SIZE	CAGE CODE	DRAWING NO	RESTRICTED TO
		A3	00779	C=2108609	-
SCALE 20:1		SHEET 1	OF 3	REV C2	

LOC	DIST	REVISIONS					
		P	LTR	DESCRIPTION	DATE	DWN	APVD
-	-			SEE SHEET 1			

① 4 <2108609-5 : FOR MBV62562101>

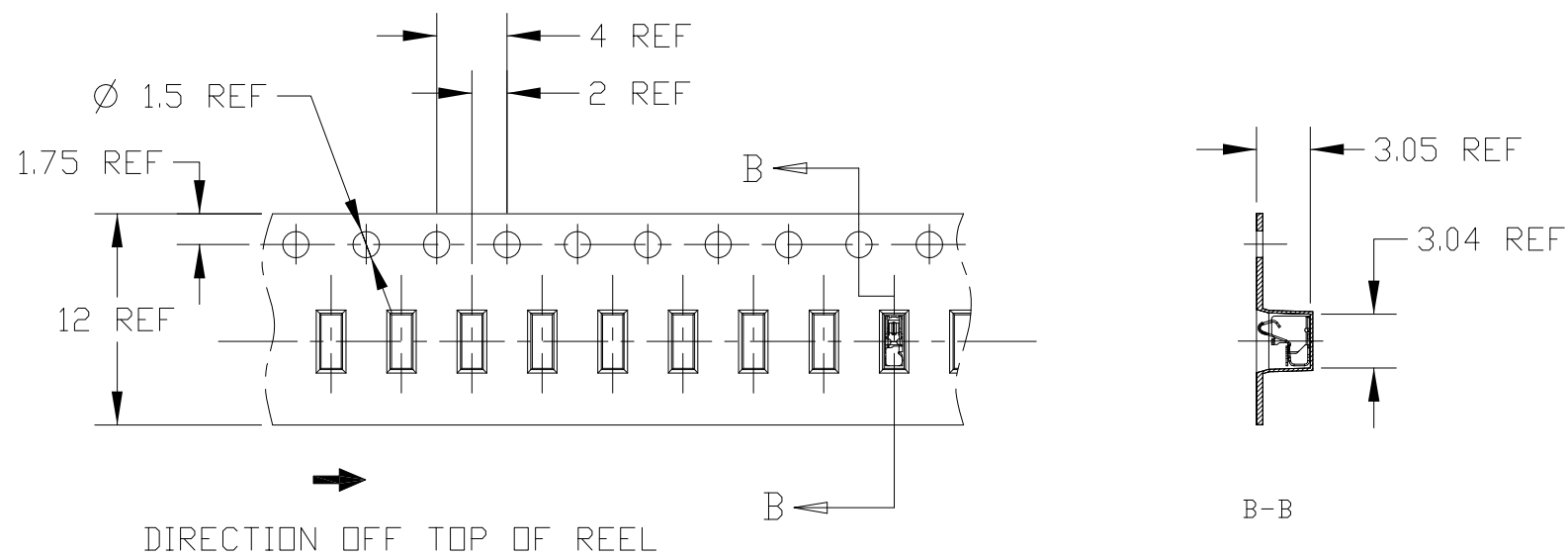

① **TE**

MBV62562101-YYYYMMDD-*****-HK000120

SPEC: 3.0H SPRING FINGER WITH EMBOSS

Company Name: TE CONNECTIVITY
Tyco Part Number : 2108609-5

RoHS
H/F

- 1. LG PART NO. 2. FINAL INSPECTION(YYYMMDD)
- 3. VENDOR PRODUCTION LOT NO. 4. VENDOR CODE

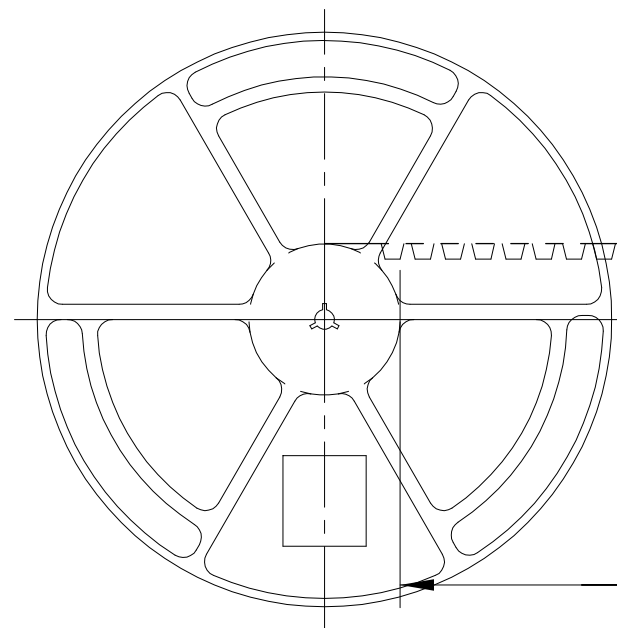
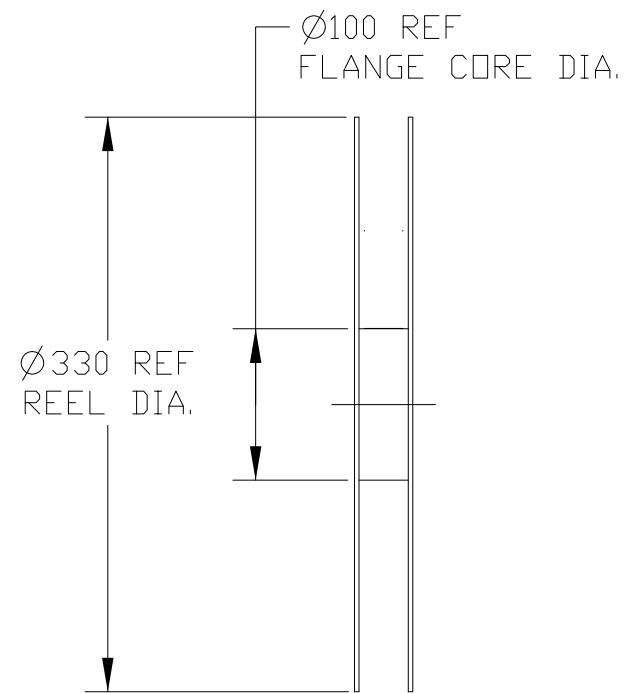

WEEDING THE COVER TAPE, AROUND THE OUTER PERIPHERY IN A TURN

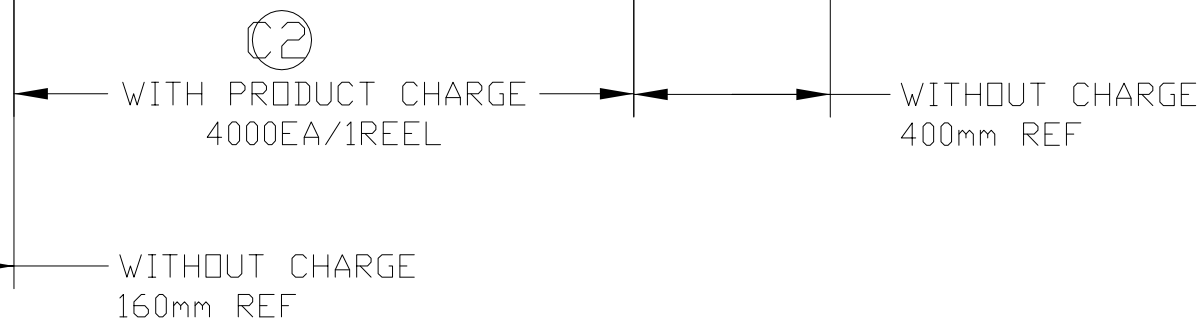
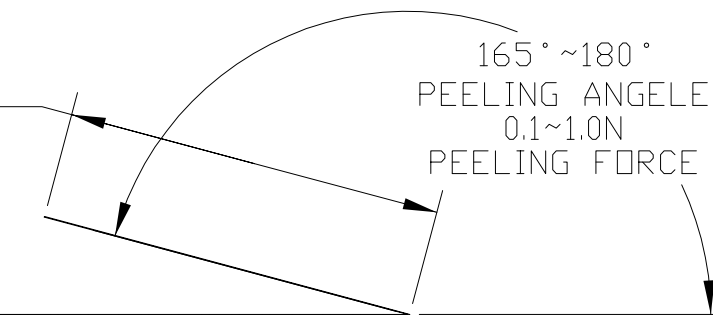

THIS DRAWING IS A CONTROLLED DOCUMENT.		DWN	08FEB2013		TE TE Connectivity				
DIMENSIONS: mm		CHK	08FEB2013						
TOLERANCES UNLESS OTHERWISE SPECIFIED: ± 0.15		APVD	08FEB2013						
0-PLC ± 1-PLC ±0.5 2-PLC ±0.13 3-PLC ±0.013 4-PLC ±0.0001 ANGLES ± FINISH -		NAME	JH KIM						
MATERIAL -		PRODUCT SPEC	108-XXXXX		SIZE	CAGE CODE	DRAWING NO	RESTRICTED TO	
		APPLICATION SPEC	-		A3	00779	©=2108609	-	
		WEIGHT	-		CUSTOMER DRAWING		SCALE 20:1	SHEET 2 OF 3	REV C2

LOC	DIST	REVISIONS			
P	LTR	DESCRIPTION	DATE	DWN	APVD
-	-	SEE SHEET 1			

(C1) 4 <2108609-6 : FOR EAG63651901>

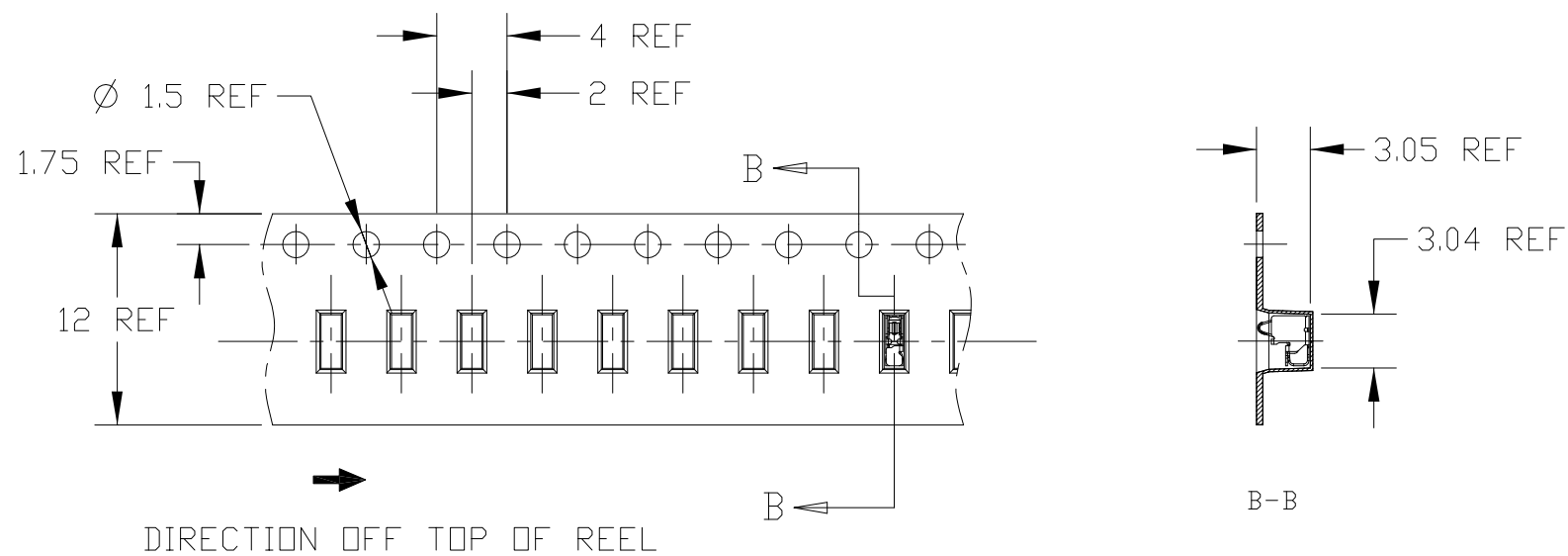

(C1) **TE**

EAG63651901-YYYYMMDD-*****-HK000120
 SPEC: 3.0H SPRING FINGER WITH EMBOSS
 Company Name: TE CONNECTIVITY
 Tyco Part Number : 2108609-5

RoHS H/F

1. LG PART NO. 2. FINAL INSPECTION(YYYMMDD)
 3. VENDOR PRODUCTION LOT NO. 4. VENDOR CODE

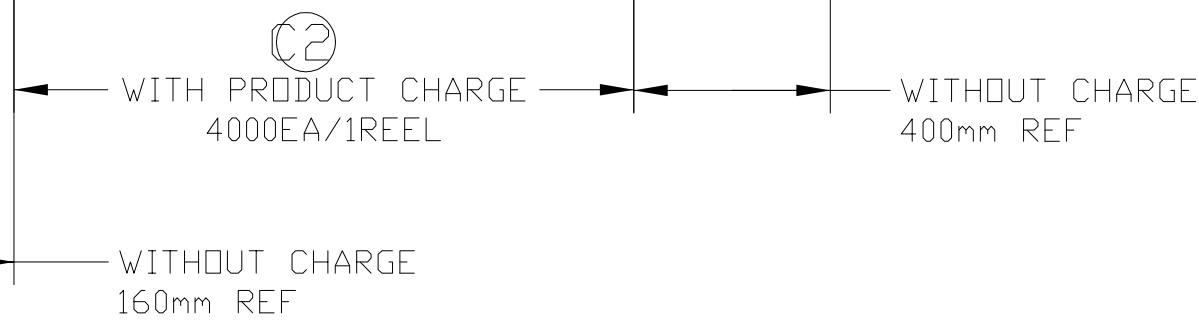
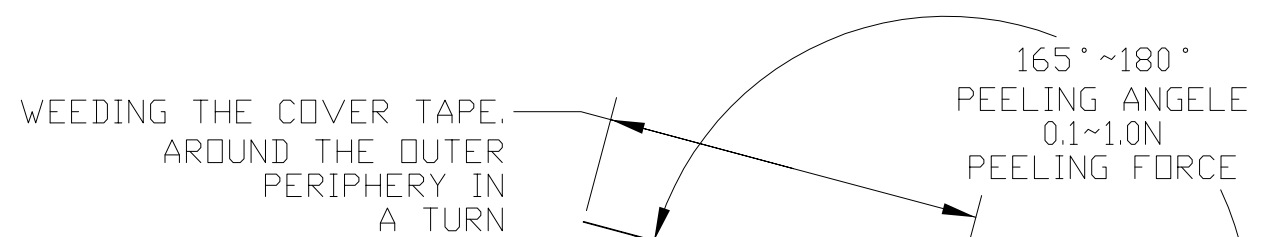
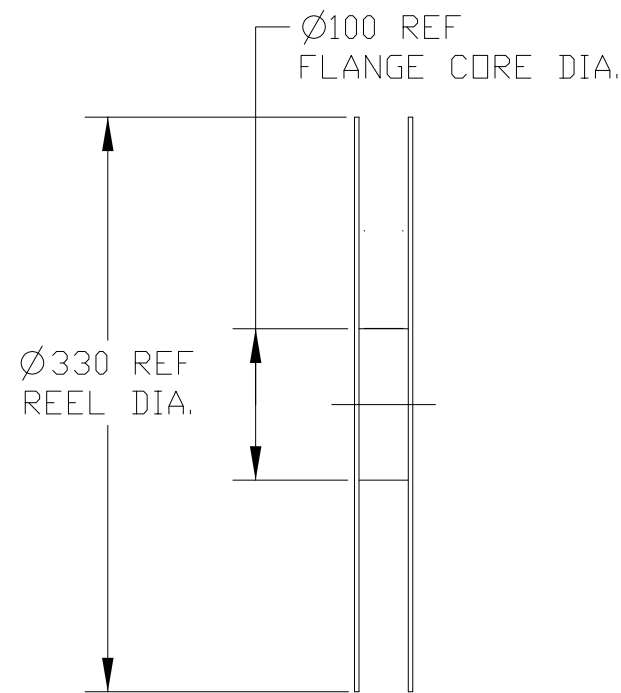

THIS DRAWING IS A CONTROLLED DOCUMENT.		DWN	JH GONG	08FEB2013	 TE Connectivity	NAME		SPRING FINGER 3.0H		
DIMENSIONS: mm		CHK	JH KIM	08FEB2013		PRODUCT SPEC		SIZE	CAGE CODE	DRAWING NO
TOLERANCES UNLESS OTHERWISE SPECIFIED: ±0.15		APVD	JH KIM	08FEB2013		APPLICATION SPEC		A3	00779	C=2108609
0-PLC ± 1-PLC ±0.5 2-PLC ±0.13 3-PLC ±0.013 4-PLC ±0.0001 ANGLES ± FINISH -		PRODUCT SPEC		WEIGHT		RESTRICTED TO		-		
MATERIAL -		CUSTOMER DRAWING		SCALE 20:1		SHEET 3 OF 3		REV C2		

单击下面可查看定价，库存，交付和生命周期等信息

[>>TE Connectivity\(泰科\)](#)