

REVISIONS					
P	LTR	DESCRIPTION	DATE	DWN	APVD
T		REVISED PER ECO 20-008593	6-24-21	CT	DM

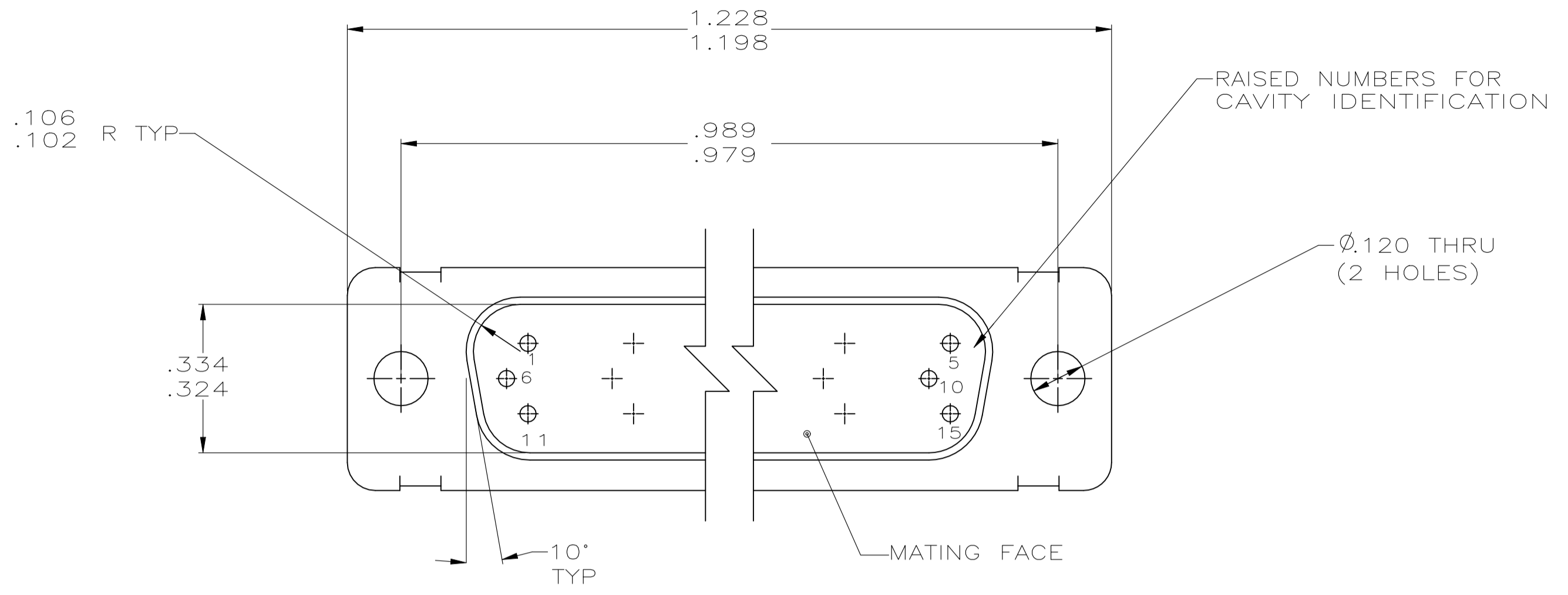

- THIS PLUG WILL MATE WITH ANY SIZE 1, 15 POSN. RCPT. IN AMPLIMITE SERIES.
 - CONNECTOR SUPPLIED WITHOUT CONTACTS; SHOWN FOR ILLUSTRATION ONLY.
 - BE-CU RETENTION CLIPS ARE INCLUDED IN INSERT AND INSTALLED WITH TINES POINTING TOWARDS MATING FACE.
 - OVERALL DIMENSIONS DO NOT INCLUDE RAISED CAVITY IDENTIFICATION.
 - MARKING FAR SIDE REFERS TO WIDE SIDE OF KEYSTONE. NEAR SIDE REFERS TO NARROW SIDE OF KEYSTONE.
- 6 ONLY PART NO. 211673-7 IS SUPPLIED WITH CONTACTS.
 7 100% INSPECTION REQUIRED PER BOEING 1B01:
 A. VISUAL
 B. DWV
 C. IR
 8 CUSTOMER REQUIRES SINGLE LOT DATE CODE.
 9 SPECIAL REQUIREMENTS:
 A. TEST TWO CONNECTORS PER LOT FOR COMPLIANCE TO GROMMET PEEL STRENGTH REQUIREMENTS.
 B. TEST ALL CIRCUIT CAVITIES FOR MISALIGNMENT OR EXCESSIVE ADHESIVE.

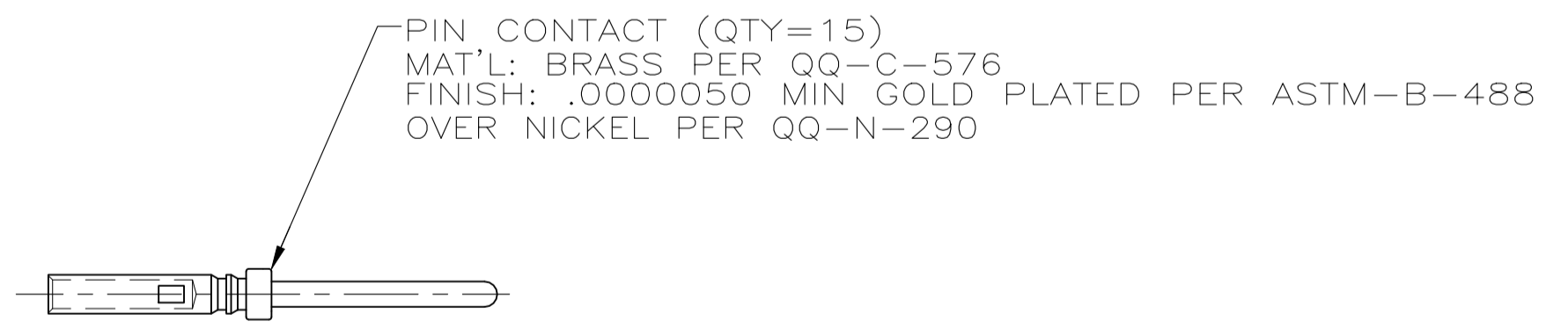
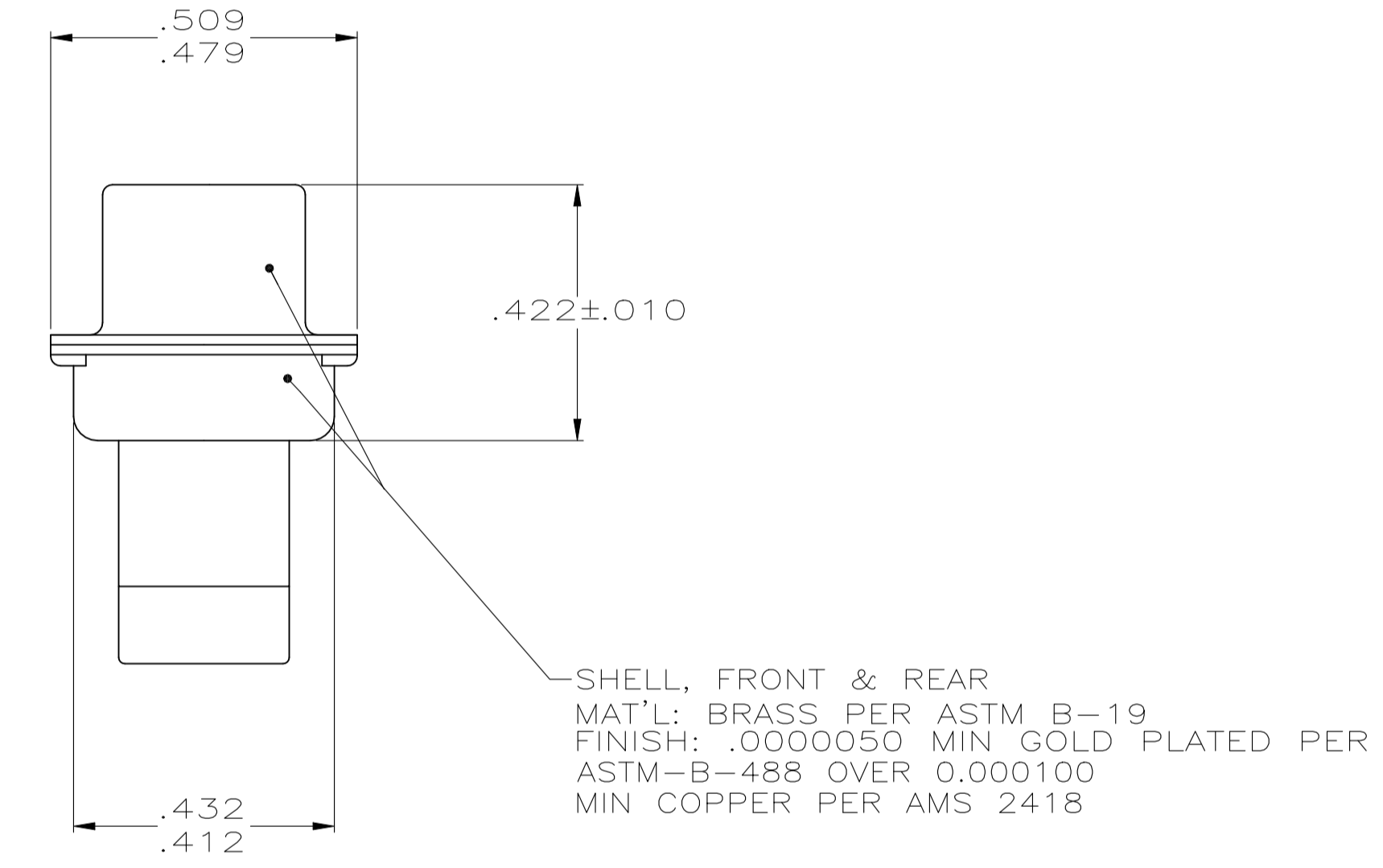
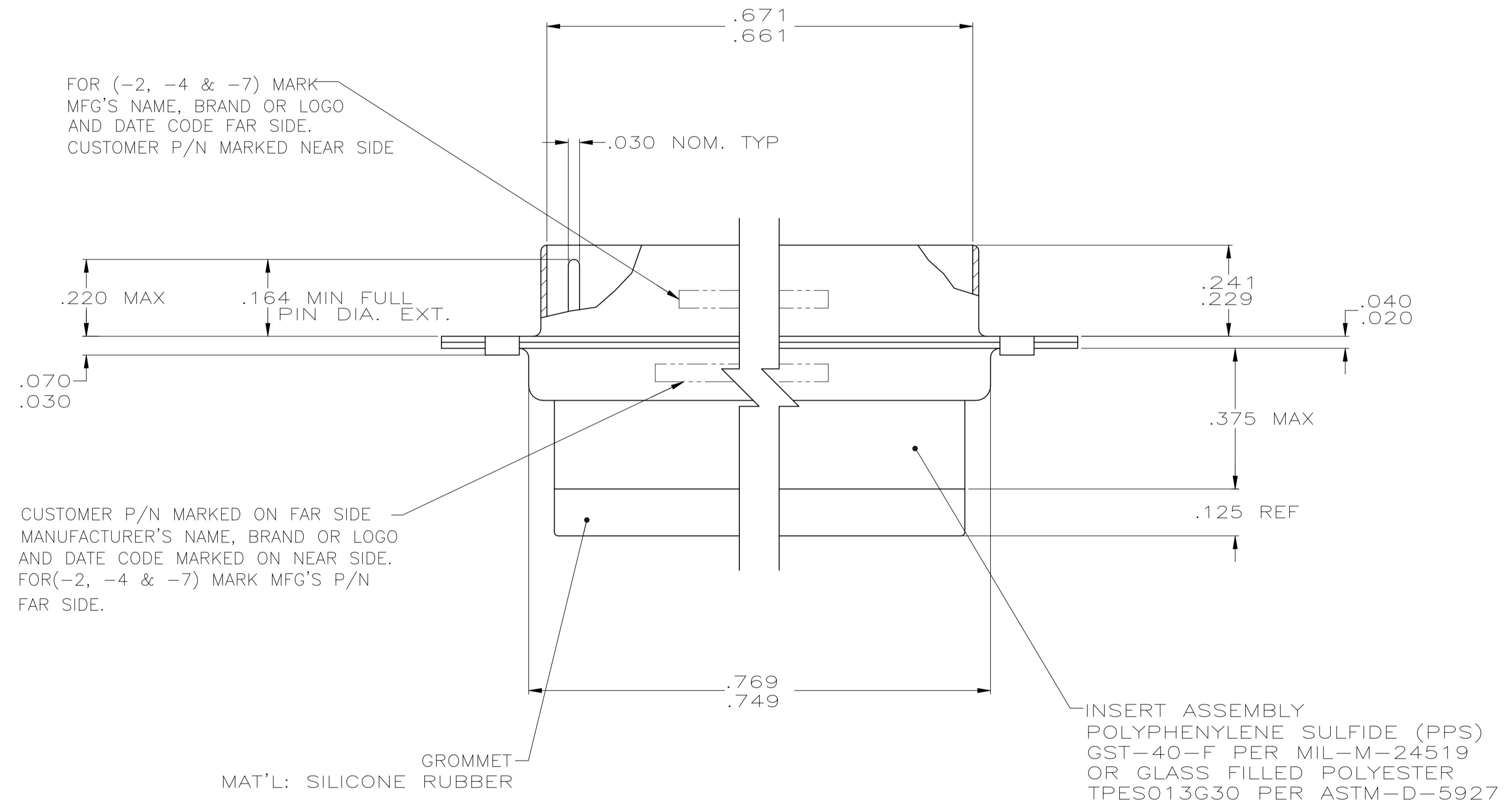

REMARKS	CUSTOMER PART NO.	PART NO.
7 8	1B01-031PHW	1-211673-1
6	B010648-0001	211673-7
		211673-4
9 8	2A065-013V	211673-2
7	1B01-031	211673-1

THIS DRAWING IS A CONTROLLED DOCUMENT.

DIMENSIONS: INCHES
 TOLERANCES UNLESS OTHERWISE SPECIFIED:
 0. PLC ± -
 1. PLC ± -
 2. PLC ± -
 3. PLC ± .005 [0.13]
 4. PLC ± -
 ANGLES ± -

MATERIAL: SEE CALLOUTS
 FINISH: SEE CALLOUTS

DIN J. KAISER 3-11-04
 CWK 3-25-04
 L. OH 3-25-04
 APVD L. OH 3-25-04

STE TE Connectivity
 NAME: PLUG ASSY, AMPLIMITE, 15 POSN., SIZE 1, SERIES 90, NON-MAG, SPECIAL WITH GROMMET
 PRODUCT SPEC: -
 APPLICATION SPEC: -
 SIZE: A1
 CAGE CODE: 00779
 DRAWING NO: 211673
 WEIGHT: 0.000000
 RESTRICTED TO: -
 CUSTOMER DRAWING: -
 SCALE: 4:1
 SHEET: 1 of 1
 REV: T

单击下面可查看定价，库存，交付和生命周期等信息

[>>TE Connectivity\(泰科\)](#)