

JACK MOUNTING HOLE
(PREFERRED)

JACK ASSEMBLY: D-621-0412

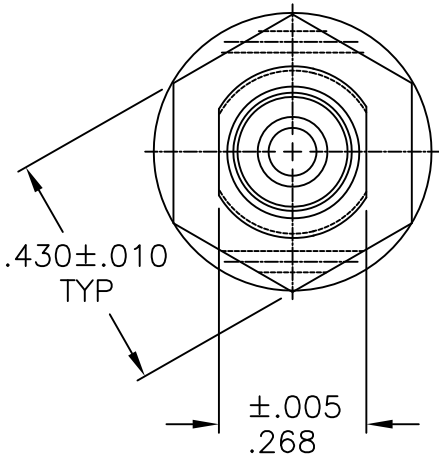

REVISION		
REV	DESCRIPTION	DATE
D	REVISED PER DCR NUMBER T-16795	
E	REVISED PER DCR NUMBER T-31786	5/9/03
F	REVISED PER ECO NUMBER 14-015910	21/10/14

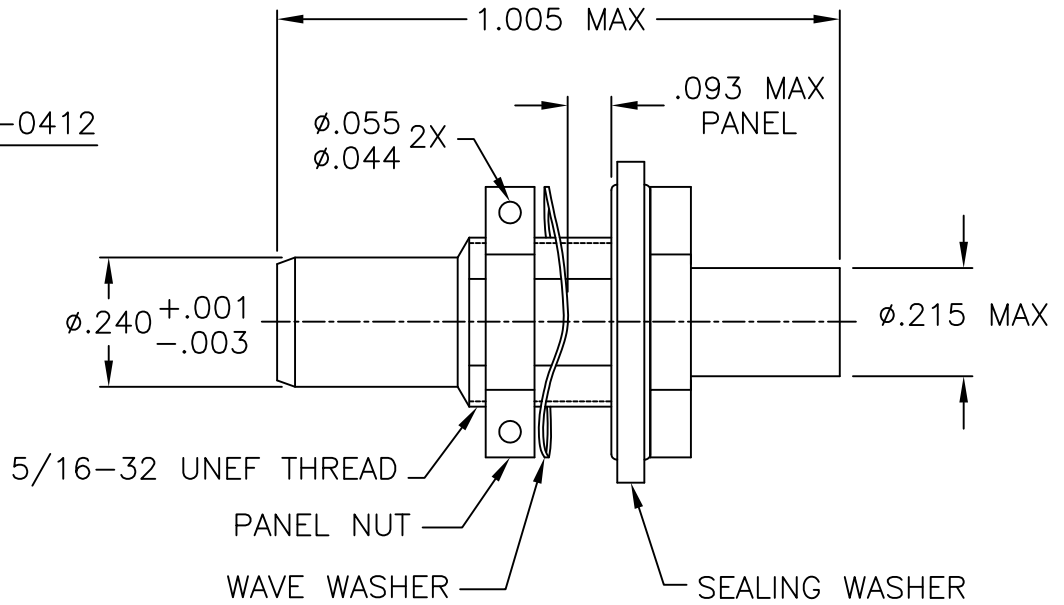

PLUG ASSEMBLY: D-621-0411

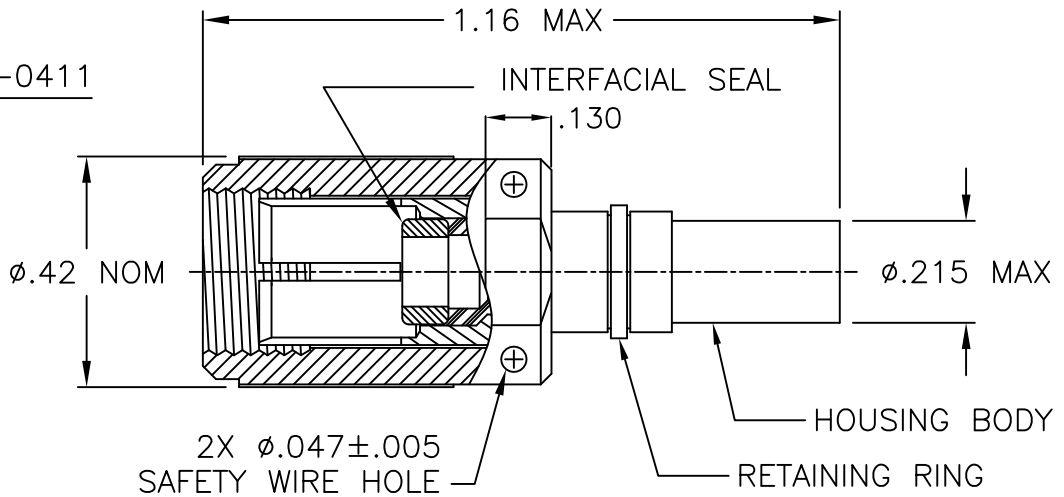
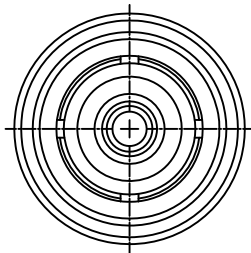

CUSTOMER DRAWING

UNLESS OTHERWISE SPECIFIED
DIMENSIONS ARE INCHES. METRIC
DIMENSIONS ARE IN BRACKETS.

DRAWN J.B.K. DATE 91 AUG 9



Raychem
Products

DECIMAL TOLERANCES
.XXX ± --- [--- mm]
.XX ± --- [--- mm]
.X ± --- [--- mm]

ANGLE TOLERANCE
.X ± ---

WEIGHT

MATERIAL
FINISH

TITLE
CONNECTOR, TRIAXIAL
SUBMINIATURE
THREADED COUPLER

CAD FILE T31786A

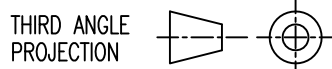

SIZE A CODE IDENT. NO. 06090 DWG. NO. D-621-0411/0412

DO NOT SCALE THIS DRAWING

SHEET 1 OF 2

SPECIFICATIONS

SEE SHEET 1 FOR REVISION

1.0 MATERIALS AND FINISHES

- 1.1 HOUSING BODY: (PLUG) BRASS ALLOY PER ASTM-B16, TIN PLATED PER ASTM-B545 OVER NICKEL PER MIL-C-26074.
(JACK) BECU PER ASTM-B196, TB00 OR TD04, TIN PLATED PER ASTM-B545, OVER NICKEL PER MIL-C-26074.
- 1.1.1 INSULATION (MIP): POLYETHERSULFONE
- 1.2 COUPLING NUT: BRASS ALLOY PER ASTM-B16, TIN PLATED PER ASTM-B545 OVER NICKEL PER MIL-C-26074.
(PLUG)
- 1.3 PANEL NUT: BRASS ALLOY PER ASTM-B16, TIN PLATED PER ASTM-B545 OVER NICKEL PER MIL-C-26074
(JACK)
- 1.4 WAVE WASHER: SPRING STEEL OR BECU, TIN PLATED PER ASTM-B545 OVER NICKEL PER MIL-C-26074.
(JACK)
- 1.5 INTERFACIAL SEAL (PLUG): SILICONE RUBBER
- 1.6 SEALING WASHER: ELASTOMER: SILICONE PER A-A-59588 (SAE-AMS3304)
WASHER: STAINLESS STEEL PER SAE-AMS5513, HALF-HARD OR ANNEALED, PASSIVATED PER SAE AMS-QQ-P-35.

2.0 CONTACTS

2.1 THE CONNECTORS WILL ACCOMMODATE THE FOLLOWING TYCO ELECTRONICS/RAYCHEM CONTACTS:

CABLE TYPE	TRIAxIAL	TWINAXIAL	COAXIAL
CONTACTS	D-602-44 (PIN) D-602-45 (SOCKET)	D-602-0126 (PIN) D-602-0127 (SOCKET)	D-610-09 (PIN) D-610-10 (SOCKET)

3.0 SEE ES-61162 FOR CABLE ACCOMODATION AND TERMINATION INFORMATION. ANY OTHER APPLICATIONS SHOULD BE SUBMITTED TO RAYCHEM FOR EVALUATION.

4.0 PERFORMANCE REQUIREMENTS

4.1 REFER TO TYCO ELECTRONICS/RAYCHEM SPECIFICATION D-6025 FOR PRODUCT PERFORMANCE AND QUALIFICATION REQUIREMENTS.

5.0 GENERAL CHARACTERISTICS

- 5.1 OPERATING TEMPERATURE: -65°C TO 125°C
- 5.2 INSULATION RESISTANCE: GREATER THEN 5K MEG
- 5.3 DIELECTRIC STRENGTH: 900 VAC @ 60 Hz
- 5.4 CURRENT RATING: 3 AMPS MAX
- 5.5 CONTACT RESISTANCE: INITIAL: 8 MILLIOHMS MAX.
- 5.6 MATING COUPLE TORQUE: 10 INCH/LBS MAX.
- 5.7 PANEL NUT TORQUE (JACK): 10-15 INCH/LBS (WHEN INSTALLING IN PANEL)
- 5.8 INSERTION FORCE: 3 LBS MAX.
- 5.9 WITHDRALWAL FORCE: 1 OUNCE MAX
- 5.10 CONTACT RETENTION TERMINATED: 20 LBS MIN.
- 5.11 DURABILITY: 500 CYCLES
- 5.12 CORROSION RESISTANCE: 1000 HOURS

CUSTOMER DRAWING

DRAWN	J.B.K.	91 AUG 9	SIZE	CODE IDENT. NO.	DWG. NO.	REV
CAD FILE:T31786B			A	06090	D-621-0411/0412	F
DO NOT SCALE THIS DRAWING				SCALE: NONE		SHEET 2 OF 2

If this document is printed it becomes uncontrolled. Check for the latest revision

单击下面可查看定价，库存，交付和生命周期等信息

[>>TE Connectivity\(泰科\)](#)