

THIS DRAWING IS UNPUBLISHED. RELEASED FOR PUBLICATION
 © COPYRIGHT - By - ALL RIGHTS RESERVED.

REVISIONS					
P	LTR	DESCRIPTION	DATE	DWN	APVD
	Y1	REVISED PER ECO-16-004000	08OCT2016	NK	MZ

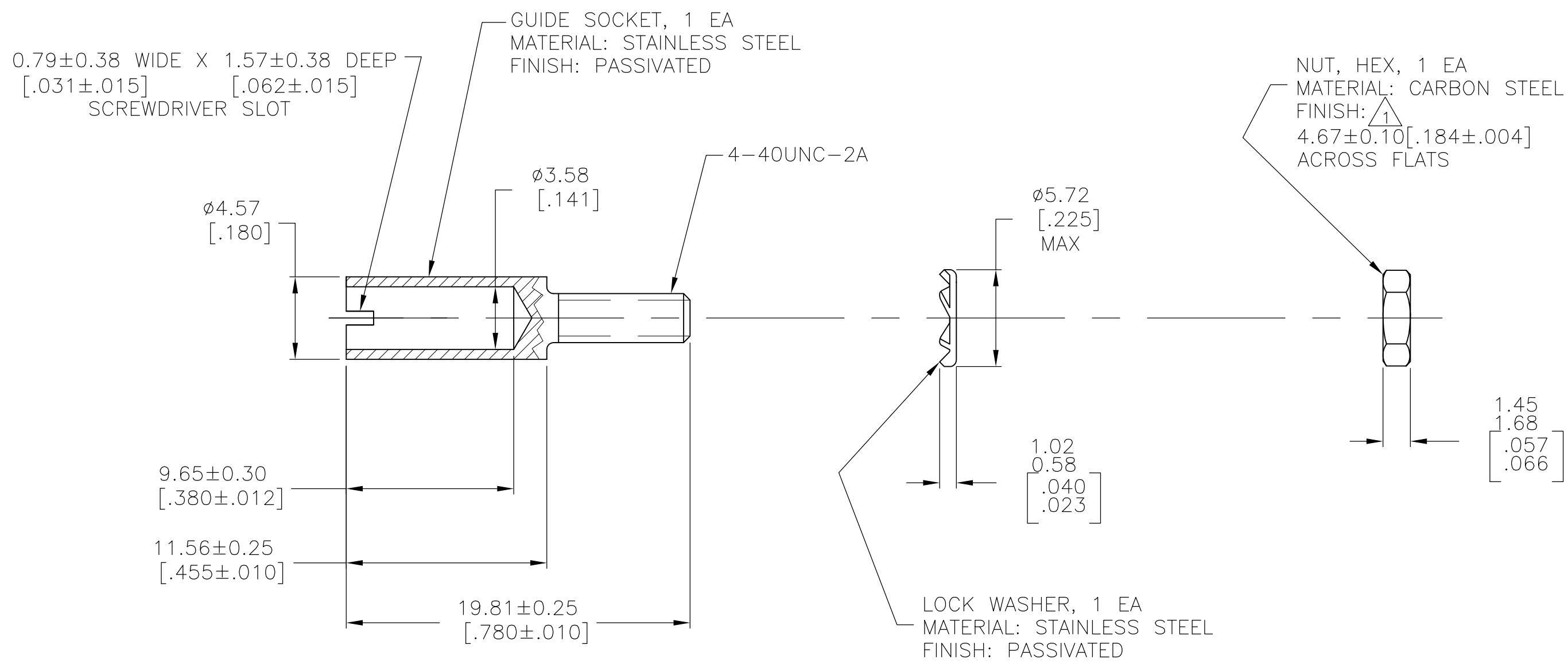

³ OBSOLETE	1-200390-0
	200390-9
SUPERSEDED BY 200390-9	200390-2
	PART NUMBER

- ¹ ZINC PLATE.
- ³ SPECIAL PACKAGING - ONE UNASSEMBLED UNIT PER BAG

THIS DRAWING IS A CONTROLLED DOCUMENT.		DWN W.G.LENKER 1-20-95	STE TE Connectivity		
		CHK R.STONE 1-24-95			
DIMENSIONS: mm [INCHES]		TOLERANCES UNLESS OTHERWISE SPECIFIED:		NAME	
		0 PLC	± -	CENTER GUIDE SOCKET KIT, UNASSEMBLED, M SERIES	
		1 PLC	± -		
		2 PLC	± 0.13 [.005]		
		3 PLC	± -		
MATERIAL		FINISH		SIZE	CAGE CODE
SEE CALLOUT		SEE CALLOUT		A3	00779
				DRAWING NO	RESTRICTED TO
				C-200390	-
				WEIGHT	SCALE
				CUSTOMER DRAWING	4:1
				SHEET	REV
				1 OF 1	Y1

单击下面可查看定价，库存，交付和生命周期等信息

[>>TE Connectivity\(泰科\)](#)