

THIS DRAWING IS UNPUBLISHED. RELEASED FOR PUBLICATION
 © COPYRIGHT BY TYCO ELECTRONICS CORPORATION. ALL RIGHTS RESERVED.

LOC	DIST	REVISIONS			
P	LTR	DESCRIPTION	DATE	DWN	APVD
AF	50	E1	ECR-06-003925 (REDRAWN IN AUTOCAD)	27JAN06	HMR/GDP

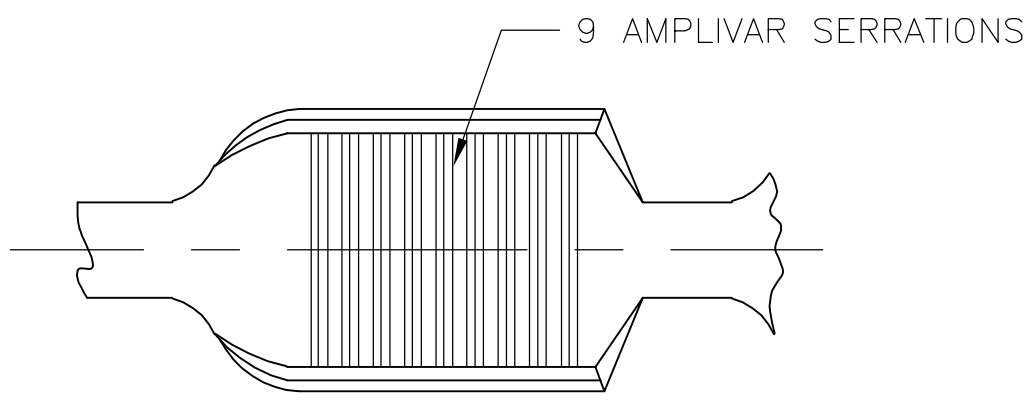

1. PRODUCT PROVIDED IN STRIP FORM ON REELS; BREAKS MAY BE PRESENT.
2. DIMENSIONS IN BRACKETS ARE IN INCHES.
3. PRELIMINARY—NOT FOR PRODUCTION.
4. CRIMP WIDTH: .110 F (AMPLIVAR TYPE)
 CRIMP HEIGHT (±.002)=(TOTAL CMA+8770)/191,200
 GENERAL APPLICATION GUIDELINES MUST BE FOLLOWED AS SPECIFIED IN CATALOG #82221
 FOR APPLICATOR INFORMATION CALL:1-800-722-1111
 FOR PRODUCT INFORMATION CALL:1-800-522-6752

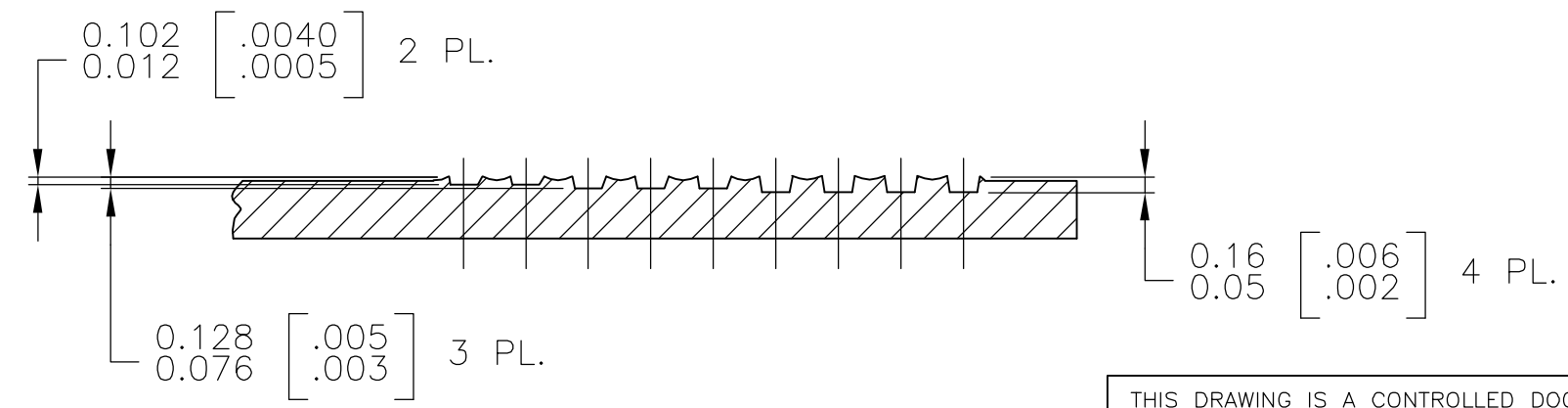
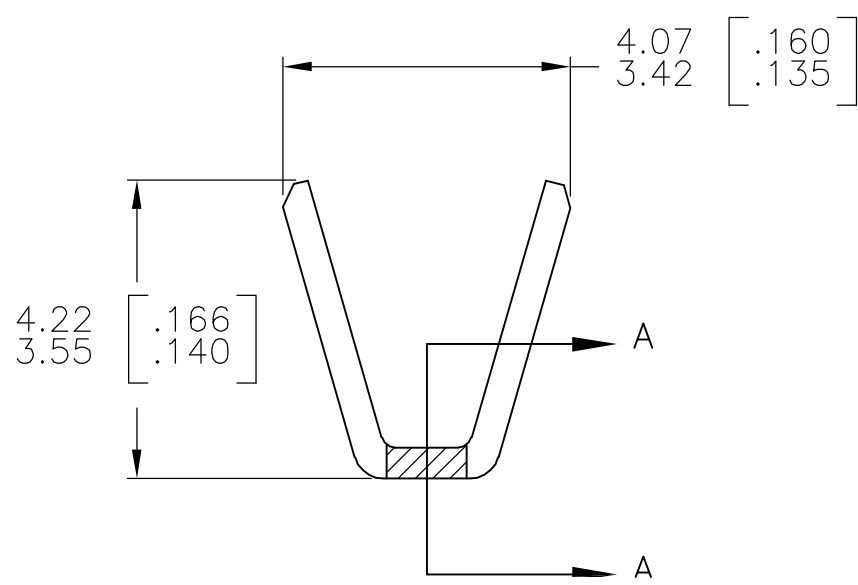
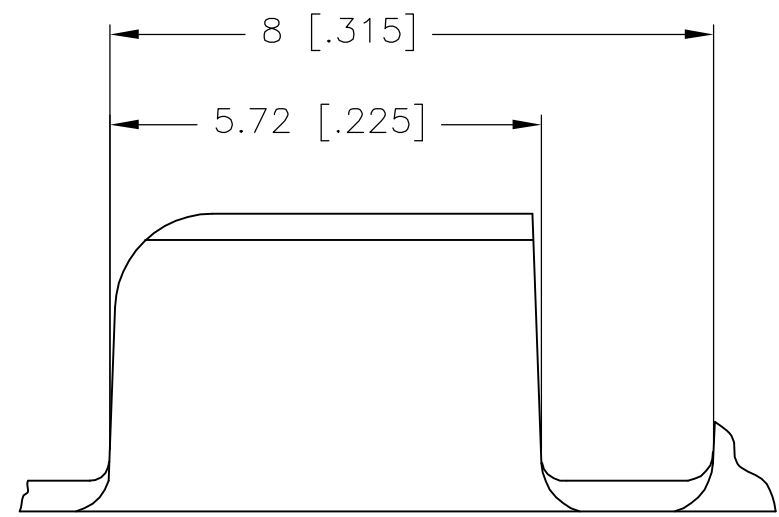

SECTION A-A
 SCALE : 20:1

METRIC

REVERSE	62307-3	4
STANDARD	62307-2	
REELING	PART NO	

THIS DRAWING IS A CONTROLLED DOCUMENT.		DWN RAGHAVENDRA 27JAN06	Tyco Electronics Corporation Harrisburg, PA 17105-3608	
DIMENSIONS: mm [INCHES]	TOLERANCES UNLESS OTHERWISE SPECIFIED:	CHK G.D.PORTA	APVD G.D.PORTA	
	0 PLC ± -	PRODUCT SPEC	NAME	
	1 PLC ± -	APPLICATION SPEC	SIZE CAGE CODE DRAWING NO RESTRICTED TO	
	2 PLC ± 0.38[.015]	114-2003	A3	00779 C-62307
	3 PLC ± -	WEIGHT -	CUSTOMER DRAWING	
	4 PLC ± -	CUSTOMER DRAWING	SCALE 10:1	SHEET 1 OF 1
	ANGLES ± 1'0"			REV E1
MATERIAL 0.41[.016] BRASS	FINISH TIN PL.			

单击下面可查看定价，库存，交付和生命周期等信息

[>>TE Connectivity\(泰科\)](#)