

REVISIONS			
REV	DESCRIPTION	DATE	APPROVED
B1	REVISED PER ECO-11-005294	14APR11	HMR

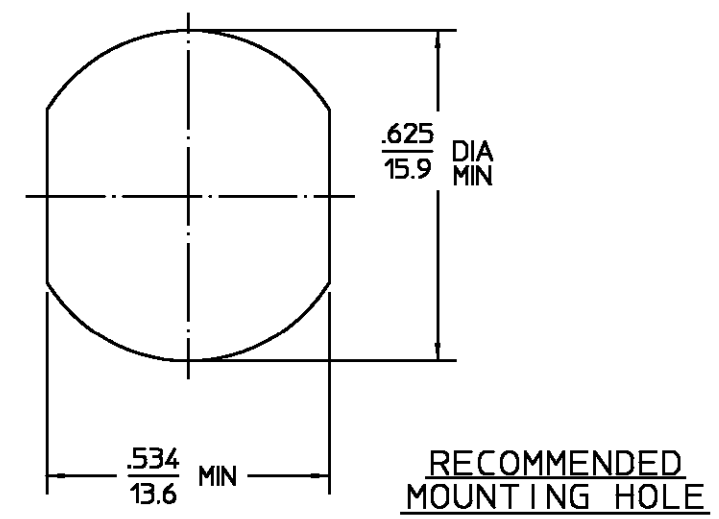

ELECTRICAL	MECHANICAL	ENVIRONMENTAL
Nominal Impedance (Ohms) <u>50</u>	Interface Dimensions MIL-STD-348A, Fig. 310.2 (OSM) & 304.2 (N)	Temperature Rating <u>-65°C to +125°C</u>
Frequency Range (GHz) DC to <u>15</u>	Recommended Mating Torque: OSM: 7-10 in-lbs	Vibration MIL-STD-202, Method 204, Condition B
Volt Rating (VRMS MAX) @ Sea Level <u>335</u>	Type N: 12-15 in-lbs	Shock MIL-STD-202, Method 213, Condition I.
VSWR DC - 12.4GHz: <u>1.06+0.005f(GHz) MAX</u>	Mating Characteristics: OSM-Insertion (MAX lbs) <u>3.0</u>	Thermal Shock MIL-STD-202, Method 107, Condition C, except high temp shall be +115°C
12.4 - 15.0GHz: <u>.83+0.023f(GHz) MAX</u>	Type N-Insertion (MAX lbs) <u>2.0</u>	Moisture Resistance MIL-STD-202, Method 106
Insertion Loss (dB MAX) <u>.18 @ 9GHz</u>	OSM-Withdrawal (MIN oz) <u>1.0</u>	Corrosion - MIL-STD-202, Method 101, Condition B, 5% salt spray
RF Leakage (dB MIN) <u>-65 @ 2-3 GHz</u>	Type N-Withdrawal (MIN oz) <u>2.0</u>	
Corona, 70,000 Ft (VRMS MIN) <u>250</u>	Force to Engage and Disengage OSM (in-lbs MAX) <u>2.0</u>	
Dielectric Withstanding Voltage (VRMS MIN) @ Sea Level <u>1,000</u>	Type N (in-lbs MAX) <u>6.0</u>	
Contact Resistance (Milliohms MAX) Center Contact <u>4.1</u>	Center Contact Captivation Axial (lbs) <u>6.0</u>	
Outer Contact <u>2.2</u>	Radial (in-oz) <u>4.0</u>	
Cable to Housing <u>N/A</u>	Cable Retention Axial Force (lbs) <u>N/A</u>	
RF High Potential @ Sea Level (VRMS MIN @ 5 MHz) <u>1,000</u>	Torque (in-oz) <u>N/A</u>	
I.R.(Megohms MIN) <u>5,000</u>	Weight (Grams) <u>TBD</u>	

COMPONENT	MATERIAL	FINISH
HOUSING MOUNTING NUT LOCKWASHER	STAINLESS STEEL PER ASTM-A484 AND ASTM- A582, TYPE 303	PASSIVATE PER ASTM-A380
DIELECTRIC	TFE FLUOROCARBON PER ASTM-D-1457	N/A
CENTER CONTACT	BRASS PER ASTM-B-16, HALF HARD	GOLD PLATE PER MIL-G-45204
GASKET	SILICONE RUBBER PER ZZ-R-765	N/A

UNLESS OTHERWISE SPECIFIED DIMENSIONS ARE IN INCHES TOLERANCE ON	DRAWN BY SWA	DATE 11/9/84
FRAC. DEC. ANGLES	CHECKED BY MLB	11/15/84
± 1/64 ±.005 ± °	APPD BY DRG	11/27/84

These drawings and specifications are the property of Omni Spectra Incorporated and shall not be reproduced or copied or used in whole or in part as the basis for the manufacture or sale of item(s) without written permission.		USE ASS'Y PROCEDURE	NO. AP. <u>N/A</u>	
---	--	---------------------	--------------------	--

TITLE OSM JACK TO OSN JACK BULKHEAD FEEDTHROUGH ADAPTER			
SIZE B	CODE IDENT NO. 26805	1057463-1	REV B1
SCALE 3:1			SHEET 1 OF 1

单击下面可查看定价，库存，交付和生命周期等信息

[>>TE Connectivity\(泰科\)](#)