

REVISIONS					
P	LTR	DESCRIPTION	DATE	DMN	APVD
C		REVISED PER ECO-06-25468	11/08/06	SS	SH
C1		REVISED PER ECO-09-022908	08OCT09	KK	AEG
D		REVISED PER ECO-16-018356	22MAR2017	RS	MZ

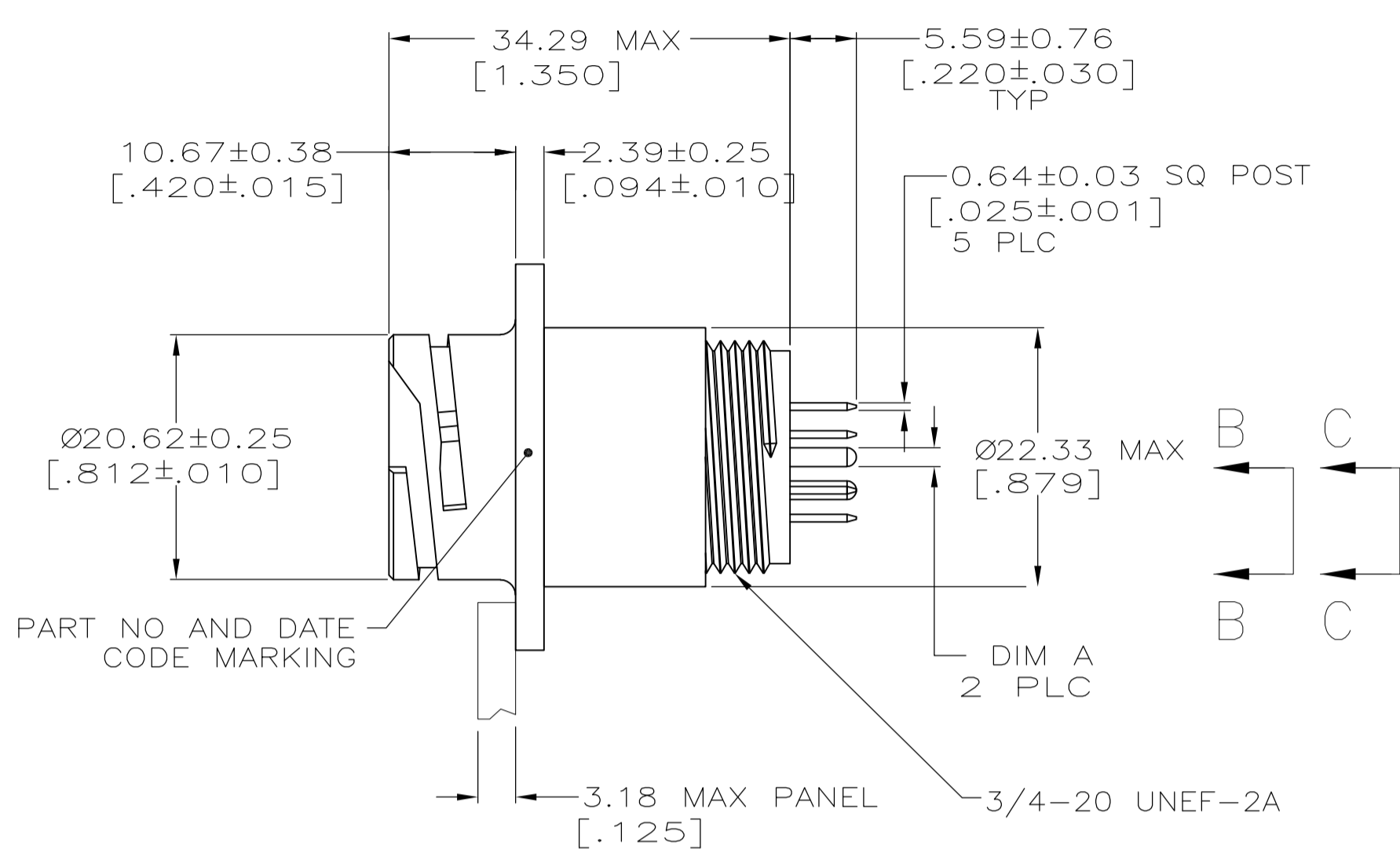

1. CAVITY IDENTIFICATION ON FRONT AND REAR FACE.
- RECEPTACLE: NYLON, UL 94V-0 RATED, BLACK.
PIN CONTACT WITH 0.64[.025] SQ POST: BRASS.
PIN CONTACT WITH Ø1.57[.062] POST: COPPER ALLOY.
SPRING: STAINLESS STEEL.
INSERTS: BRASS.
- PIN CONTACT WITH SQ POST:
CONTACT: 0.76um[.000030] MIN GOLD FOR A DISTANCE OF 6.35[.250] FROM MATING END, ALL OVER 1.27um[.000050] MIN NICKEL.
POST: 2.54um[.000100] MIN TIN-LEAD OVER 1.27um[.000050] MIN NICKEL.
- PIN CONTACT WITH Ø1.57[.062] POST: 5.08um[.000200] MIN SILVER ALL OVER 1.27um[.000050] MIN NICKEL.
- PIN CONTACT WITH SQ POST:
CONTACT: 0.76um[.000030] MIN GOLD FOR A DISTANCE OF 6.35[.250] FROM MATING END, ALL OVER 1.27um[.000050] MIN NICKEL.
POST: 2.54um[.000100] MIN TIN OVER 1.27um[.000050] MIN NICKEL.
- OBsolete PARTS: OBsolete CIS STREAMLINING PER D.RENAUD/D.SINISI

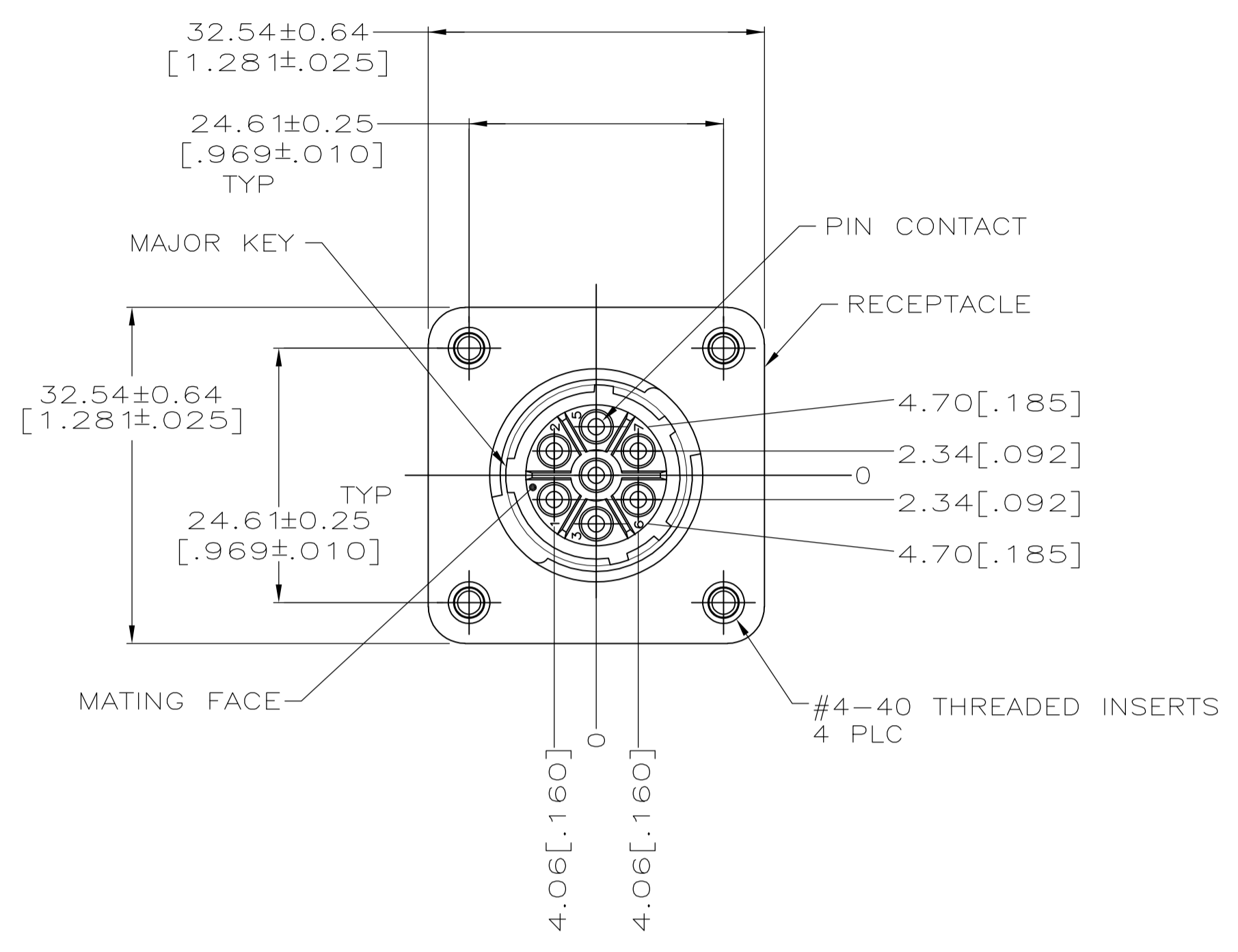
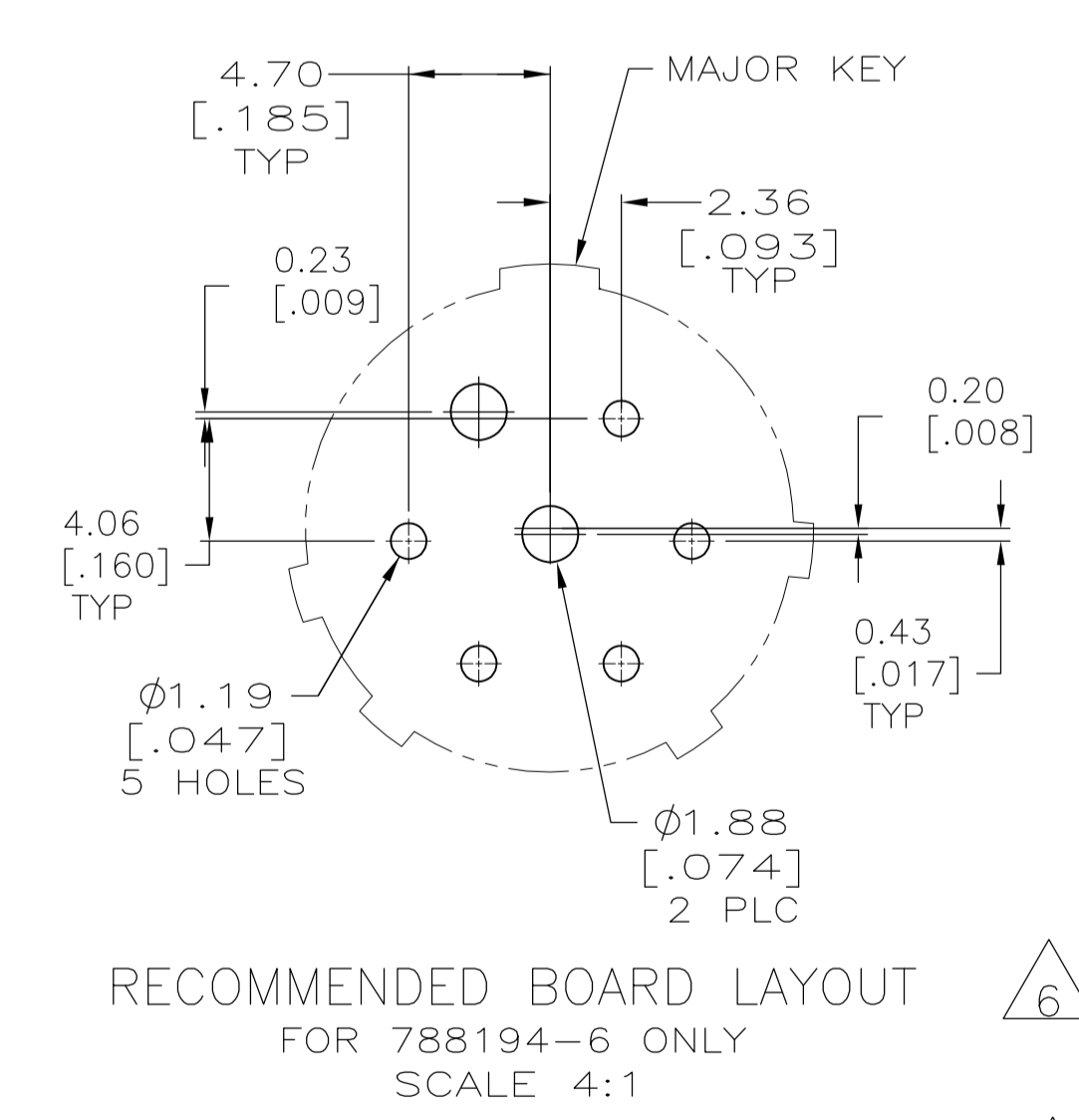
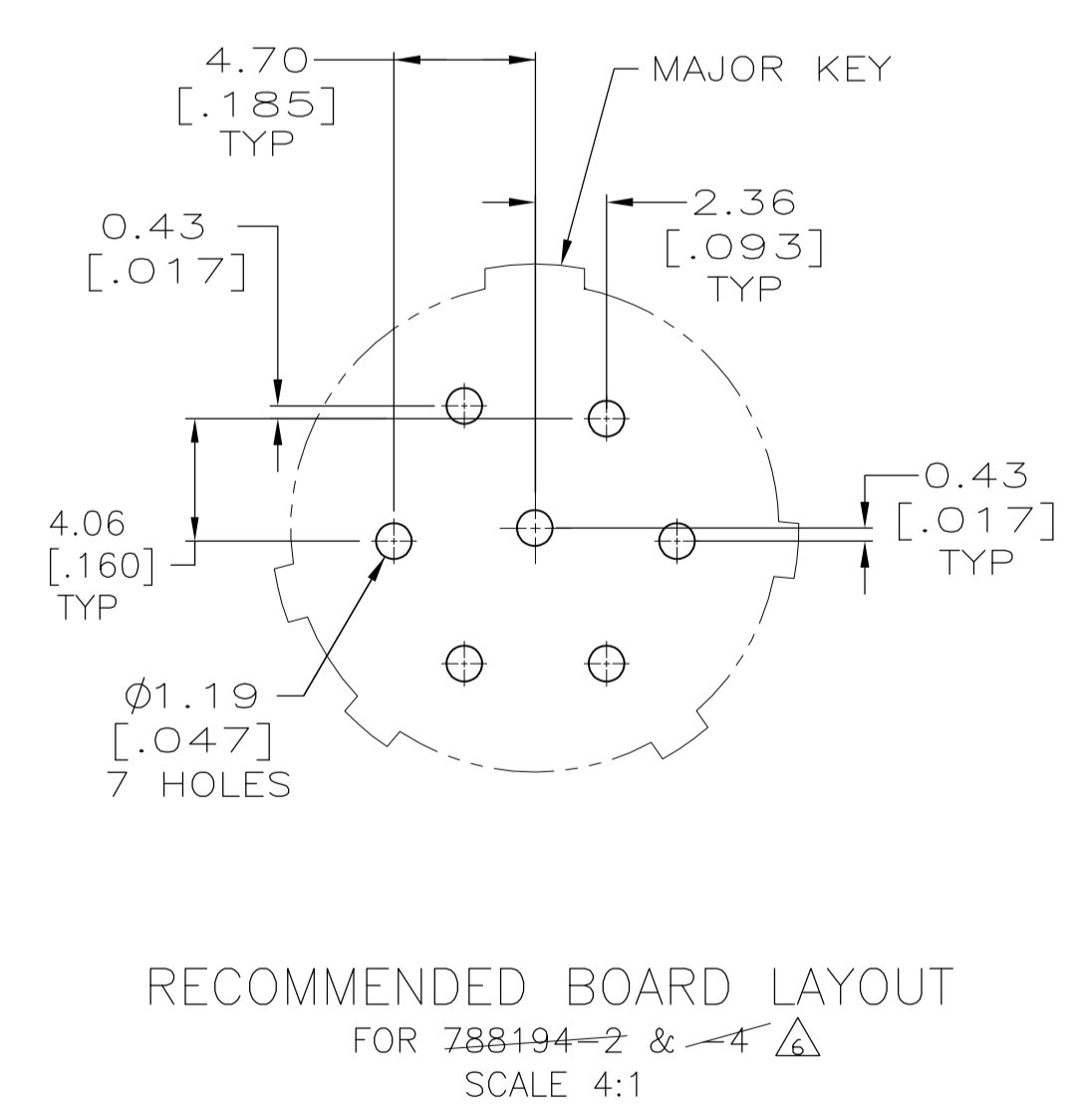
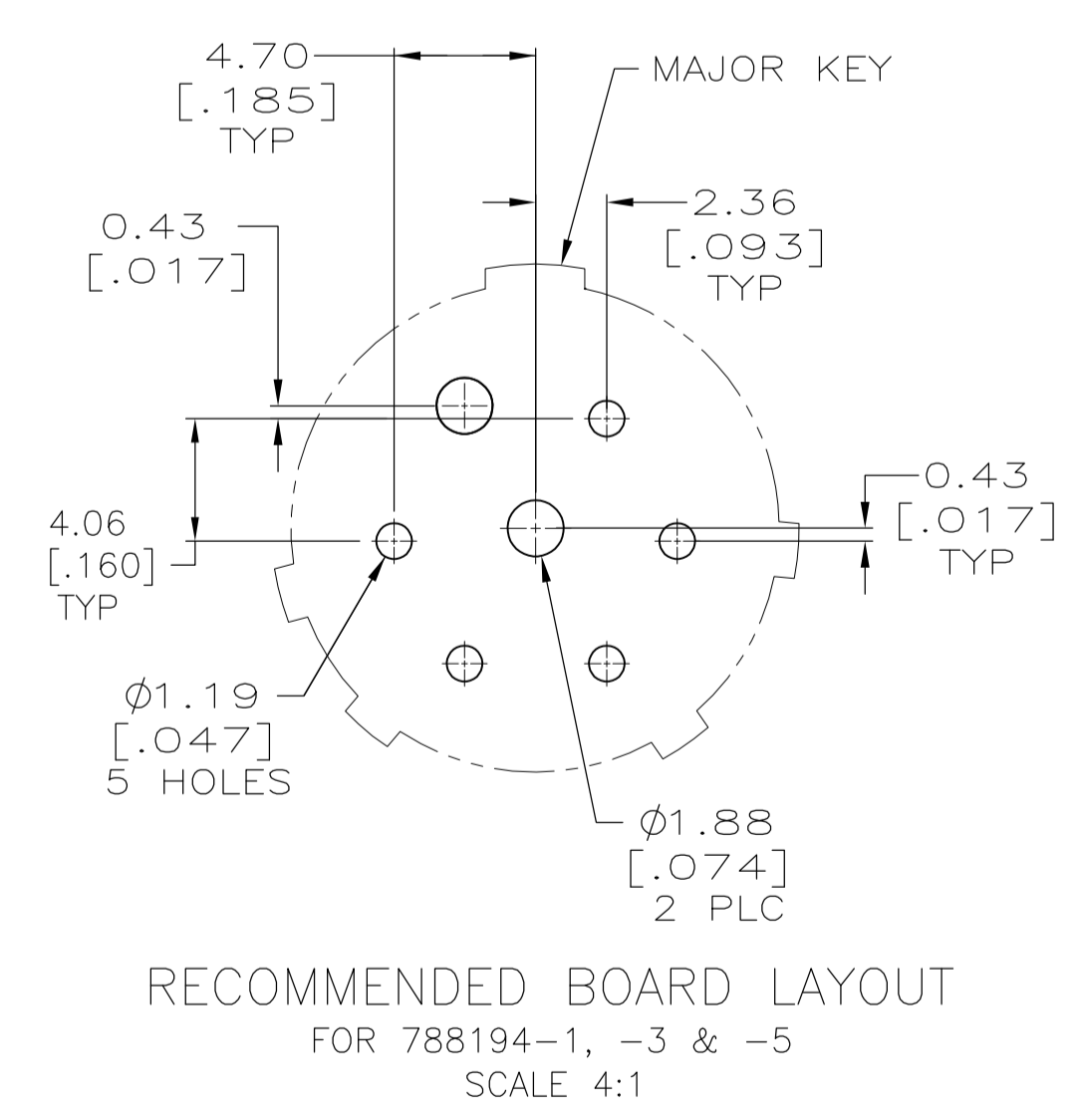
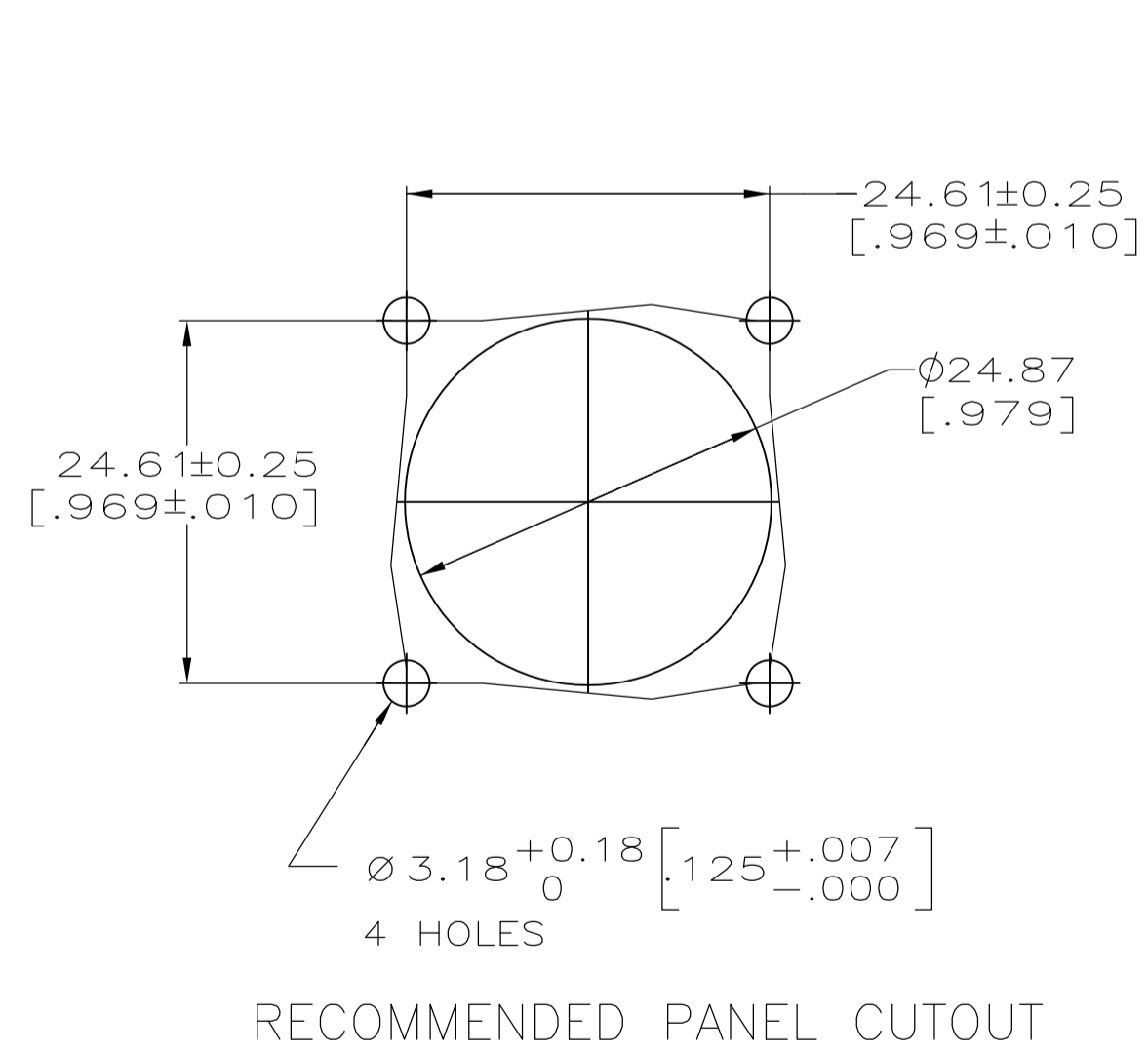
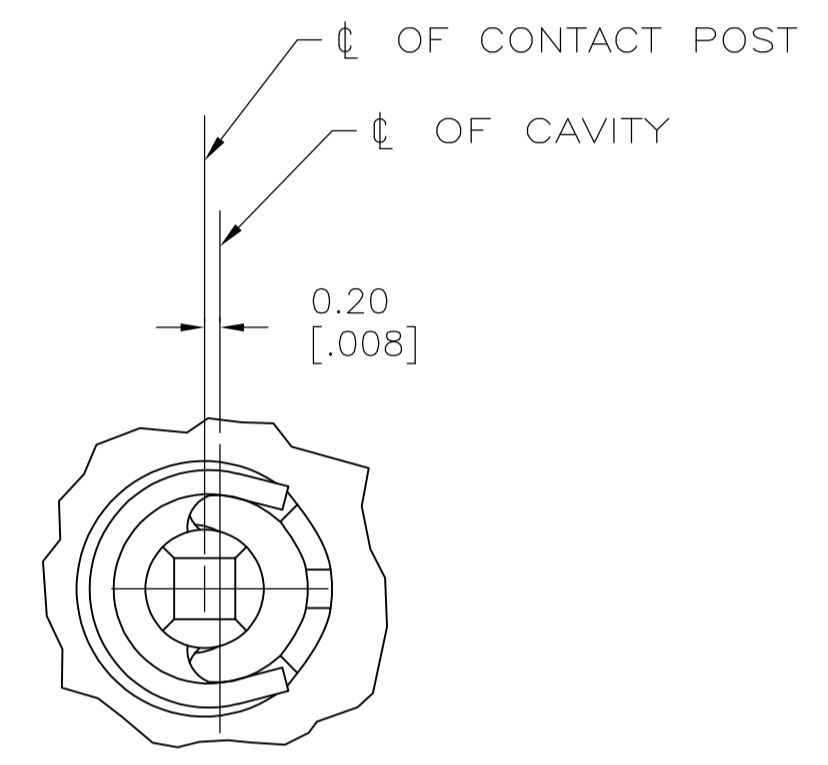
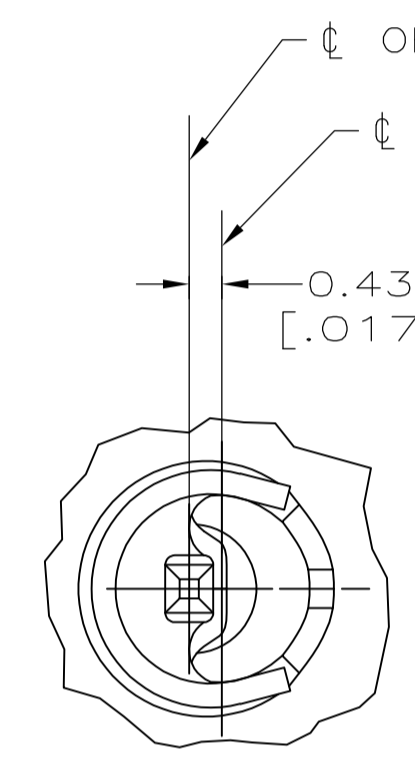

	.062 DIA.	$\triangle\triangle\triangle$	788194-6
OBsolete	.045 SQ	$\triangle\triangle\triangle$	788194-5
OBsolete	.025 DIA.	$\triangle\triangle\triangle$	788194-4
	.062 DIA.	$\triangle\triangle\triangle\triangle$	788194-3
OBsolete	.025 SQ	$\triangle\triangle\triangle$	788194-2
OBsolete	.062 DIA.	$\triangle\triangle\triangle\triangle$	788194-1
	DIM A	PIN CONTACT	PART NUMBER

DIMENSIONS:		TOLERANCES UNLESS OTHERWISE SPECIFIED:		APPROVED:		NAME:	
mm	[INCHES]	0 PLC	± -	DIN	K. WHITAKER	28-MAR-2000	TE Connectivity
		1 PLC	± -	CHK	M. CHACKO	28-MAR-2000	
		2 PLC	± 0.13[.005]	APVD	M. CHACKO	28-MAR-2000	
		3 PLC	± -	NAME			RECEPTACLE ASSEMBLY, STANDARD SEX, 13-7, CPC
		4 PLC	± -	PRODUCT SPEC			108-10024
		ANGLES	± -	APPLICATION SPEC			114-10038
MATERIAL	FINISH	WEIGHT		SIZE	CAGE CODE	DRAWING NO	RESTRICTED TO
\triangle	-	-		A1	00779	788194	-
CUSTOMER DRAWING				SCALE	2:1	SHEET	1 of 1
				REV			D

单击下面可查看定价，库存，交付和生命周期等信息

[>>TE Connectivity\(泰科\)](#)